

PILOT'S OPERATING HANDBOOK **AND FAA APPROVED** **AIRPLANE FLIGHT MANUAL**

for the CIRRUS DESIGN SR20
Aircraft Serials 2220, 2339 and Subsequent with
Cirrus Perspective+ Avionics System



FAA Approved in Normal Category based on 14 CFR 23. This document must be carried in the airplane at all times and be kept within the reach of the pilot during all flight operations.

THIS MANUAL INCLUDES THE MATERIAL REQUIRED TO BE FURNISHED TO THE PILOT BY 14 CFR 23 AND ADDITIONAL INFORMATION PROVIDED BY CIRRUS AIRCRAFT AND CONSTITUTES THE FAA APPROVED AIRPLANE FLIGHT MANUAL.

Model - Serial #:

Registration #:

FAA Approved

Addison P. Tower

Jan 15, 2020
Date

Manager, Southwest Flight Test Section, AIR-713
Federal Aviation Administration
Ft. Worth, TX



Copyright © 2019 - All Rights Reserved
Cirrus Design Corporation
4515 Taylor Circle
Duluth, MN 55811

List of Effective Pages

Use this page to determine the current effective date for each page in the AFM. Supplements are issued individually and are controlled by the Log of Supplements Page in Section 9.

Dates of original issue and revised pages are:

Reissue A 15 Jan 2020
Revision A1 09 Nov 2021

Page	Status	Page	Status	Page	Status
CoverPage-i	Reissue A	2-17	Revision A1	3-27	Reissue A
CoverPage-ii	Reissue A	2-18	Reissue A	3-28	Reissue A
LOEP-1	Revision A1	2-19	Reissue A	3-29	Reissue A
LOEP-2	Revision A1	2-20	Reissue A	3-30	Reissue A
LOEP-3	Revision A1	2-21	Revision A1	3-31	Revision A1
LOEP-4	Revision A1	2-22	Reissue A	3-32	Revision A1
Frontmatter-1	Reissue A	2-23	Reissue A	3-33	Reissue A
Frontmatter-2	Revision A1	2-24	Revision A1	3-34	Reissue A
Frontmatter-3	Reissue A	2-25	Reissue A	3-35	Reissue A
Frontmatter-4	Revision A1	2-26	Reissue A	3-36	Reissue A
1-1	Revision A1	2-27	Reissue A	3-37	Reissue A
1-2	Revision A1	2-28	Reissue A	3-38	Reissue A
1-3	Reissue A	2-29	Reissue A	3-39	Reissue A
1-4	Reissue A	2-30	Reissue A	3-40	Reissue A
1-5	Revision A1	3-1	Revision A1	3A-1	Revision A1
1-6	Reissue A	3-2	Revision A1	3A-2	Revision A1
1-7	Reissue A	3-3	Revision A1	3A-3	Revision A1
1-8	Reissue A	3-4	Reissue A	3A-4	Revision A1
1-9	Reissue A	3-5	Revision A1	3A-5	Reissue A
1-10	Reissue A	3-6	Reissue A	3A-6	Reissue A
1-11	Reissue A	3-7	Reissue A	3A-7	Reissue A
1-12	Reissue A	3-8	Revision A1	3A-8	Revision A1
1-13	Reissue A	3-9	Reissue A	3A-9	Reissue A
1-14	Reissue A	3-10	Revision A1	3A-10	Reissue A
2-1	Revision A1	3-11	Revision A1	3A-11	Reissue A
2-2	Revision A1	3-12	Reissue A	3A-12	Reissue A
2-3	Reissue A	3-13	Reissue A	3A-13	Reissue A
2-4	Reissue A	3-14	Reissue A	3A-14	Reissue A
2-5	Reissue A	3-15	Reissue A	3A-15	Reissue A
2-6	Revision A1	3-16	Reissue A	3A-16	Reissue A
2-7	Revision A1	3-17	Reissue A	3A-17	Reissue A
2-8	Reissue A	3-18	Reissue A	3A-18	Reissue A
2-9	Reissue A	3-19	Reissue A	3A-19	Reissue A
2-10	Revision A1	3-20	Reissue A	3A-20	Reissue A
2-11	Reissue A	3-21	Revision A1	3A-21	Reissue A
2-12	Revision A1	3-22	Reissue A	3A-22	Reissue A
2-13	Reissue A	3-23	Reissue A	3A-23	Revision A1
2-14	Reissue A	3-24	Revision A1	3A-24	Reissue A
2-15	Revision A1	3-25	Reissue A	4-1	Revision A1
2-16	Revision A1	3-26	Reissue A	4-2	Revision A1

FAA Approved

Addison P. Tower

Digitally signed by
ADDISON P TOWER
Date: 2022.05.24 13:38:49
-05'00'

May 24, 2022
Date

Manager, Southwest Flight Test Section, AIR-713
Federal Aviation Administration
Ft. Worth, TX

List of Effective Pages (Cont.)

Page	Status	Page	Status	Page	Status
4-3	Reissue A	5-28	Revision A1	7-33	Revision A1
4-4	Reissue A	5-29	Revision A1	7-34	Revision A1
4-5	Reissue A	5-30	Revision A1	7-35	Revision A1
4-6	Reissue A	5-31	Revision A1	7-36	Revision A1
4-7	Reissue A	5-32	Revision A1	7-37	Revision A1
4-8	Reissue A	5-33	Revision A1	7-38	Revision A1
4-9	Reissue A	5-34	Revision A1	7-39	Revision A1
4-10	Reissue A	5-35	Revision A1	7-40	Revision A1
4-11	Revision A1	5-36	Revision A1	7-41	Revision A1
4-12	Reissue A	5-37	Revision A1	7-42	Revision A1
4-13	Revision A1	5-38	Revision A1	7-43	Revision A1
4-14	Revision A1	5-39	Revision A1	7-44	Revision A1
4-15	Revision A1	5-40	Revision A1	7-45	Revision A1
4-16	Revision A1	5-41	Revision A1	7-46	Revision A1
4-17	Revision A1	5-42	Revision A1	7-47	Revision A1
4-18	Reissue A	6-1	Reissue A	7-48	Revision A1
4-19	Revision A1	6-2	Reissue A	7-49	Revision A1
4-20	Revision A1	6-3	Reissue A	7-50	Revision A1
4-21	Revision A1	6-4	Reissue A	7-51	Revision A1
4-22	Revision A1	6-5	Revision A1	7-52	Revision A1
4-23	Revision A1	6-6	Revision A1	7-53	Revision A1
4-24	Revision A1	6-7	Reissue A	7-54	Revision A1
4-25	Revision A1	6-8	Reissue A	7-55	Revision A1
4-26	Revision A1	7-1	Revision A1	7-56	Revision A1
4-27	Revision A1	7-2	Revision A1	7-57	Revision A1
4-28	Revision A1	7-3	Revision A1	7-58	Revision A1
4-29	Revision A1	7-4	Revision A1	7-59	Revision A1
4-30	Revision A1	7-5	Reissue A	7-60	Revision A1
5-1	Revision A1	7-6	Reissue A	7-61	Revision A1
5-2	Revision A1	7-7	Reissue A	7-62	Revision A1
5-3	Reissue A	7-8	Reissue A	7-63	Revision A1
5-4	Reissue A	7-9	Reissue A	7-64	Revision A1
5-5	Reissue A	7-10	Reissue A	7-65	Revision A1
5-6	Reissue A	7-11	Reissue A	7-66	Revision A1
5-7	Reissue A	7-12	Reissue A	7-67	Revision A1
5-8	Reissue A	7-13	Reissue A	7-68	Revision A1
5-9	Reissue A	7-14	Revision A1	7-69	Revision A1
5-10	Reissue A	7-15	Revision A1	7-70	Revision A1
5-11	Reissue A	7-16	Reissue A	7-71	Revision A1
5-12	Reissue A	7-17	Reissue A	7-72	Revision A1
5-13	Reissue A	7-18	Reissue A	7-73	Revision A1
5-14	Reissue A	7-19	Reissue A	7-74	Revision A1
5-15	Reissue A	7-20	Reissue A	7-75	Revision A1
5-16	Reissue A	7-21	Reissue A	7-76	Revision A1
5-17	Reissue A	7-22	Revision A1	7-77	Revision A1
5-18	Reissue A	7-23	Reissue A	7-78	Revision A1
5-19	Revision A1	7-24	Reissue A	7-79	Revision A1
5-20	Revision A1	7-25	Reissue A	7-80	Revision A1
5-21	Revision A1	7-26	Revision A1	7-81	Revision A1
5-22	Revision A1	7-27	Revision A1	7-82	Revision A1
5-23	Revision A1	7-28	Revision A1	7-83	Revision A1
5-24	Revision A1	7-29	Revision A1	7-84	Revision A1
5-25	Revision A1	7-30	Revision A1	7-85	Revision A1
5-26	Revision A1	7-31	Revision A1	7-86	Revision A1
5-27	Revision A1	7-32	Revision A1	7-87	Revision A1

List of Effective Pages (Cont.)

Page	Status	Page	Status	Page	Status
7-88	Revision A1	10-9	Reissue A		
7-89	Revision A1	10-10	Reissue A		
7-90	Revision A1				
7-91	Revision A1				
7-92	Revision A1				
7-93	Revision A1				
7-94	Revision A1				
7-95	Revision A1				
7-96	Revision A1				
7-97	Revision A1				
7-98	Revision A1				
7-99	Revision A1				
7-100	Revision A1				
8-1	Reissue A				
8-2	Reissue A				
8-3	Reissue A				
8-4	Reissue A				
8-5	Reissue A				
8-6	Reissue A				
8-7	Reissue A				
8-8	Reissue A				
8-9	Reissue A				
8-10	Reissue A				
8-11	Reissue A				
8-12	Reissue A				
8-13	Reissue A				
8-14	Reissue A				
8-15	Reissue A				
8-16	Reissue A				
8-17	Reissue A				
8-18	Reissue A				
8-19	Reissue A				
8-20	Reissue A				
8-21	Reissue A				
8-22	Reissue A				
8-23	Reissue A				
8-24	Reissue A				
8-25	Reissue A				
8-26	Reissue A				
8-27	Reissue A				
8-28	Reissue A				
8-29	Reissue A				
8-30	Reissue A				
8-31	Reissue A				
8-32	Reissue A				
9-1	Reissue A				
9-2	Reissue A				
10-1	Reissue A				
10-2	Reissue A				
10-3	Reissue A				
10-4	Reissue A				
10-5	Reissue A				
10-6	Reissue A				
10-7	Reissue A				
10-8	Reissue A				

Intentionally Left Blank

SR20 Pilot's Operating Handbook (POH) Temporary Change

Information in this Temporary Change adds to, supersedes, or deletes information in the Pilot's Operating Handbook.

Affected Publications: SR20 Pilot's Operating Handbooks:

- P/N 11934-005 Revision A1
(FAA Approved)
- P/N 11934-005AR Reissue A
(FAA Approved on behalf of ANAC-DA of Argentina)
- P/N 21399-005 Reissue A
(FAA Approved on behalf of ANAC of Brazil)

Filing Instructions: Insert the following changes adjacent to the first page of each affected POH section and retain until further notice. Insert this cover page adjacent to the last page of the List of Effective Pages and retain until further notice.

Purpose: This POH Temporary Change revises fire extinguisher information in affected sections.

Affected Sections:

- Section 3 - Emergency Procedures, Smoke and Fire
 - Cabin Fire in Flight
- Section 7 - Airplane and Systems, Cabin Features
 - Fire Extinguisher



TC ODA Administrator, ODA-834662-CE, for
Manager, Flight Test & Human Factors Branch, AIR-710
Federal Aviation Administration

17 DEC 2025

Approved Date

Intentionally Left Blank

Foreword

This Pilot's Operating Handbook (POH) has been prepared by Cirrus to familiarize operators with the aircraft. Read this POH carefully. It provides operational procedures that will ensure the operator obtains the performance published in the manual, data designed to allow the most efficient and safe use of the airplane, and basic information to assist in maintaining the airplane in airworthy condition.

• NOTE •

All limitations, procedures, maintenance & servicing requirements, and performance data contained in this POH are mandatory for compliance with FAA operating rules and for continued airworthiness of the airplane.

This POH includes the material required to be furnished to the pilot by the Code of Federal Regulations (CFRs) and additional information provided by Cirrus and constitutes the FAA Approved Airplane Flight Manual for the aircraft.

The Pilot's Operating Handbook

This POH has been prepared using GAMA Specification #1 for Pilot's Operating Handbook, Revision 2, dated 18 October 1996 as the content model and format guide. However, some deviations from this specification were made for clarity. The POH is presented in loose-leaf form for ease in inserting revisions and is sized for convenient storage. Tabbed dividers throughout the POH allow quick reference to each section. Logical and convenient Tables of Contents are located at the beginning of each section to aid in locating specific data within that section. The POH is divided into ten sections as follows:

Section 1	General
Section 2	Limitations
Section 3	Emergency Procedures
Section 3A	Abnormal Procedures
Section 4	Normal Procedures
Section 5	Performance Data
Section 6	Weight and Balance
Section 7	Systems Description
Section 8	Handling and Servicing
Section 9	Log of Supplements
Section 10	Safety Information

The data presented in this POH is the result of extensive flight tests and is approved by the Federal Aviation Administration. However, as new procedures or performance data are developed, the POH will be revised.

• NOTE •

It is the responsibility of the owner to ensure that the Pilot's Operating Handbook is current at all times. Therefore, it is very important that all revisions be properly incorporated into this POH as soon as they become available.

Revising the Pilot's Operating Handbook

Two types of revisions may be issued for this Handbook: Temporary and Numbered.

Temporary revisions are printed on yellow paper, normally cover only one topic or procedure, and are issued to provide safety related information in a timely manner. All the information needed to properly file a temporary revision is included on the revision itself. Typically, a temporary revision is superseded and replaced by the next numbered revision.

Numbered revisions are printed on white paper, normally cover several subjects, and are issued as general updates to the POH. Each numbered revision includes an "Instruction Sheet", a "List of Effective Pages", and a "Revision Highlights" page. The "Instruction Sheet" is intended to assist the manual holder in removing superseded pages and inserting new or superseding pages. The "List of Effective Pages" shows the issue or revision status of all pages in the POH. The "Revision Highlights" page gives a brief description of changes made to each page in the current revision.

Identifying Revised Material

Each page in the POH has revision identification at the lower inside corner opposite the page number. Original issue pages will be identified by the words "Original Issue" at this location. In the event that the majority of pages in the POH are revised, Cirrus may determine that it is more effective to reissue the POH. Reissued pages will be identified by the word "Reissue" followed by a letter indicating the reissue level; for example, "Reissue A". Revised pages will be identified by the word "Revision" followed by the revision number at this location; for example, "Revision 2" (Original Issue, Revision 2) or "Revision B1" (Reissue B, Revision 1).

Revised material on a page can be identified by a change bar located at the outside page margin.

Revisions to the Pilot's Operating Handbook

POH revisions, temporary revisions, and supplements can be downloaded from Cirrus at www.cirrusaircraft.com, or from the Authorized Service Center website.

Paper copies of POH revisions and supplements can be purchased from Cirrus Connection at www.cirrusconnection.com.

Supplements

The Supplements section (Section 9) of this POH contains FAA Approved Supplements necessary to safely and efficiently operate the airplane when equipped with optional equipment not provided with the standard airplane or not included in the POH. Supplements are essentially “mini-handbooks” and may contain data corresponding to most sections of the POH. Data in a supplement either adds to, supersedes, or replaces similar data in the basic POH.

Section 9 includes a “Log of Supplements” page preceding all Cirrus Supplements produced for this airplane. The “Log of Supplements” page can be utilized as a “Table of Contents” for Section 9. If the airplane is modified at a non-Cirrus facility through an STC or other approval method, it is the owner’s responsibility to ensure that the proper supplement, if applicable, is installed in the POH and that the supplement is properly recorded on the “Log of Supplements” page.

FAA Approved POH Supplements must be in the airplane for flight operations when the subject optional equipment is installed or the special operations are to be performed.

Retention of Data

In the event a new title page is issued, the weight and balance data changes, the equipment list changes, or the “Log of Supplements” is replaced, the owner must ensure that all information applicable to the airplane is transferred to the new pages and the aircraft records are current. It is not a requirement that owners retain information, such as supplements, that is not applicable to their airplane.

In the event a new POH is purchased, the owner must ensure that all information applicable to the airplane is transferred to the new POH and the aircraft records are current.

Warnings, Cautions, and Notes

Warnings, Cautions, and Notes are used throughout this POH to focus attention on special conditions or procedures as follows:

• WARNING •

Warnings are used to call attention to operating procedures which, if not strictly observed, may result in personal injury or loss of life.

• CAUTION •

Cautions are used to call attention to operating procedures which, if not strictly observed, may result in damage to equipment.

• NOTE •

Notes are used to highlight specific operating conditions or steps of a procedure.

Airplane Serial Number Effectivity

For aircraft serial numbers with an alphabetical suffix, the letter designation should be ignored when reading effectivity notes in service and operating documents.

For example, "2491H" is the same as "2491" when referencing effectivity to determine applicable operation for this aircraft.

Section 1: General

Table of Contents

Introduction.....	3
The Airplane	7
Engine	7
Propeller	7
Hartzell	7
Fuel	7
Approved Fuel Grades	7
Oil	8
Maximum Certificated Weights.....	8
Cabin and Entry Dimensions.....	8
Baggage Spaces and Entry Dimensions.....	8
Specific Loadings	8
Terminology.....	9

Intentionally Left Blank

Introduction

This section contains information of general interest to pilots and owners. You will find the information useful in acquainting yourself with the airplane, as well as in loading, fueling, sheltering, and handling the airplane during ground operations. Additionally, this section contains definitions or explanations of symbols, abbreviations, and terminology used throughout this Handbook.

• NOTE •

For specific information regarding the organization of this Handbook, revisions, supplements, and procedures to be used to obtain publications, see the “Foreword” section.

All liquid volumes referenced in this publication are expressed in United States Customary Units, e.g., U.S. Gallons.

Figure 1-1: Airplane Three View

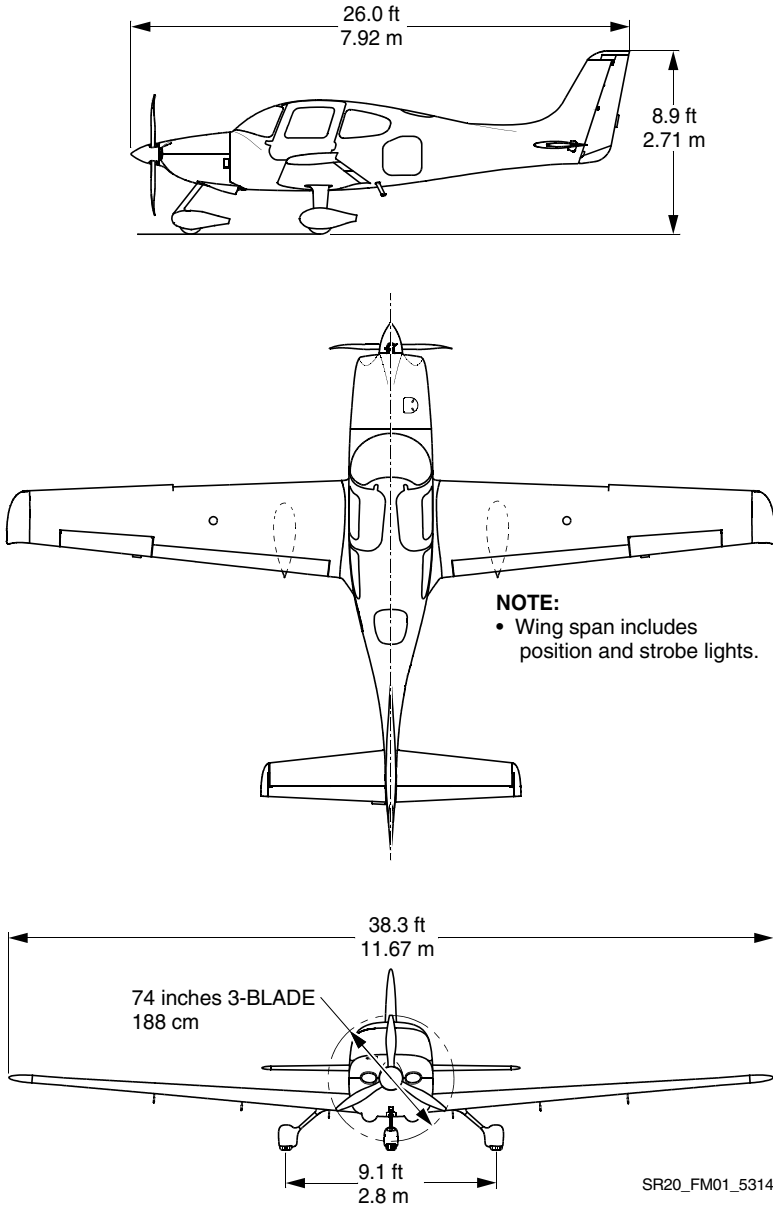
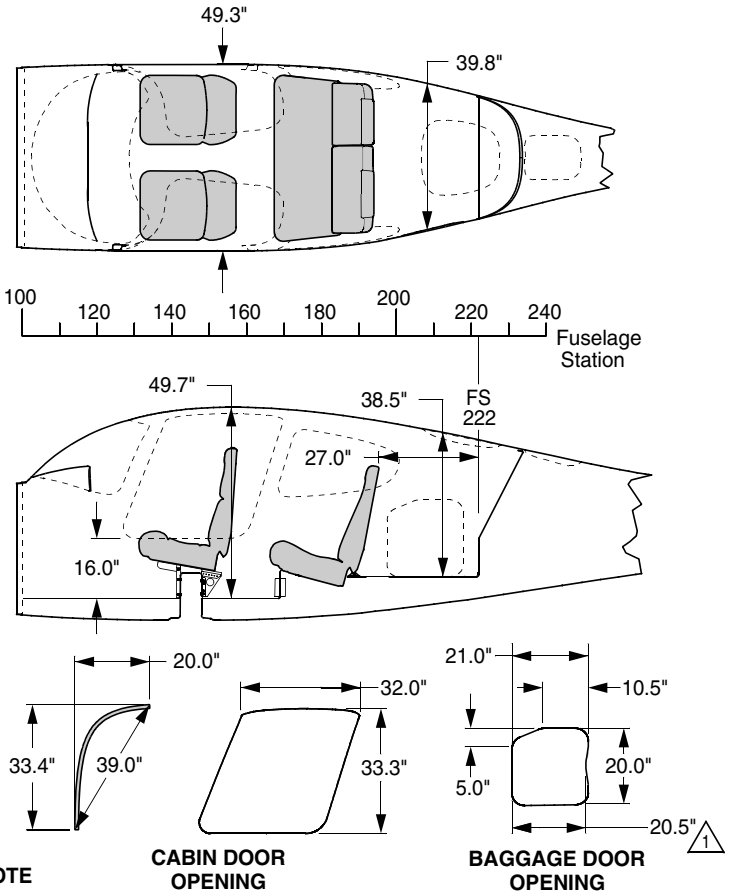

Figure 1-2: Airplane Interior Dimensions



NOTE
 △ Dimension of 20.5" only applicable to serials 8500 and subs.

SR20_FM01_5316A

Location	Length	Width	Height	Volume
Cabin	122"	49.3"	49.7"	137 cu ft
Baggage Compartment	36"	39.8"	38.5"	32 cu ft

Figure 1-3: Turning Radius

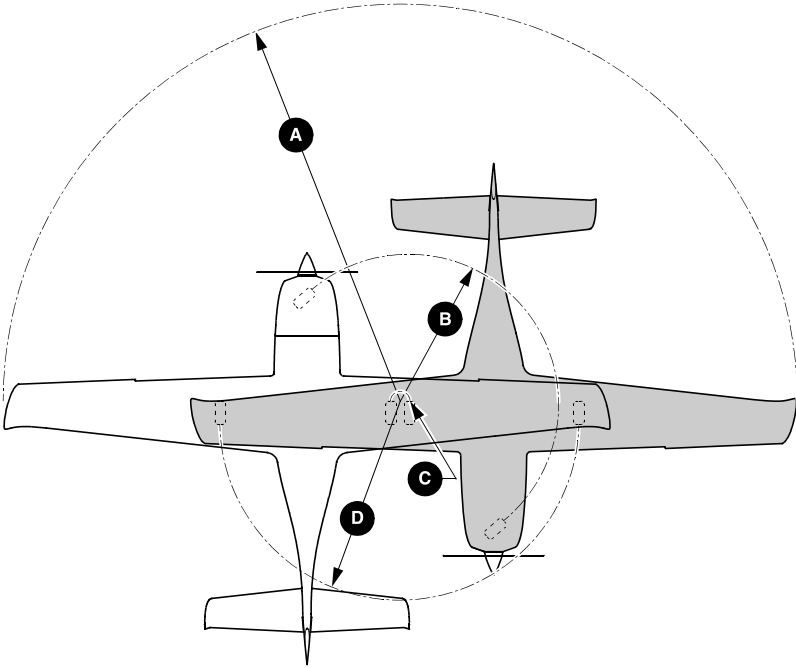

GROUND TURNING CLEARANCE

- A** RADIUS FOR WING TIP 24.3 ft. (7.41 m)
- B** RADIUS FOR NOSE GEAR 7.0 ft. (2.16 m)
- C** RADIUS FOR INSIDE GEAR 0.5 ft. (0.15 m)
- D** RADIUS FOR OUTSIDE GEAR 9.1 ft. (2.77 m)

TURNING RADII ARE CALCULATED USING ONE BRAKE AND PARTIAL POWER. ACTUAL TURNING RADIUS MAY VARY AS MUCH AS THREE FEET.

SR20_FM01_5398

The Airplane

Engine

Number of Engines	1
Number of Cylinders	4
Engine Manufacturer	Lycoming Engines
Engine Model	IO-390-C3B6
Engine Metering	Fuel Injected
Engine Cooling	Air Cooled
Engine Type.....	Horizontally Opposed, Direct Drive
Horsepower Rating.....	215 HP @ 2700 RPM

Propeller

Hartzell

Propeller Type..... Constant Speed

Three-Blade Propeller, Metal (Standard):

Model Number..... HC-E3YR-1RF/F7392S-1

Diameter

74.0" (73.0" Minimum)

Refer to Section 2, Powerplant Limitations for servicing limitations.

Three-Blade Propeller, Composite (Optional):

Model Number..... 3C1-R919A1/76C03-2

Diameter

74.0" Minimum

Fuel

Total Capacity

58.5 U.S. Gallons (221.0 L)

Total Usable

56.0 U.S. Gallons (212.0 L)

Approved Fuel Grades

100 LL Grade Aviation Fuel (Blue)

100 (Formerly 100/130) Grade Aviation Fuel (Green)

Oil

Oil Capacity (Sump)..... 7 U.S. Quarts (6.6 L)

Refer to Section 2, Powerplant Limitations, for approved oil grades.

Maximum Certificated Weights

Maximum Gross for Takeoff..... 3150 lb (1429 kg)

Maximum Baggage Compartment Loading..... 130 lb (59 kg)

Cabin and Entry Dimensions

Refer to the preceding figures for dimensions of the cabin interior and entry door openings.

Baggage Spaces and Entry Dimensions

Refer to the preceding figures for dimensions of the baggage area and baggage door opening.

Specific Loadings

Wing Loading..... 21.7 lb per square foot

Power Loading..... 14.7 lb per HP

Terminology

Table 1: General Airspeed Terminology

General Airspeed Terminology	
Terminology	Definition
KCAS	Knots Calibrated Airspeed is the indicated airspeed corrected for position and instrument error. Calibrated airspeed is equal to true airspeed in standard atmosphere at sea level.
KIAS	Knots Indicated Airspeed is the speed shown on the airspeed indicator. The IAS values published in this handbook assume no instrument error.
KTAS	Knots True Airspeed is the airspeed expressed in knots relative to undisturbed air which is KCAS corrected for altitude and temperature.
V_G	Best Glide Speed is the speed at which the greatest flight distance is attained per unit of altitude lost with power off.
V_O	Operating Maneuvering Speed is the maximum speed at which application of full control movement will not overstress the airplane.
V_{FE}	Maximum Flap Extended Speed is the highest speed permissible with wing flaps in a prescribed extended position.
V_{NO}	Maximum Structural Cruising Speed is the speed that should not be exceeded except in smooth air, and then only with caution.
V_{NE}	Never Exceed Speed is the speed that may not be exceeded at any time.
V_{PD}	Maximum Demonstrated Parachute Deployment Speed is the maximum speed at which parachute deployment has been demonstrated.
V_S	Stalling Speed is the minimum steady flight speed at which the aircraft is controllable.

General Airspeed Terminology (Continued)	
Terminology	Definition
$V_{S 50\%}$	Stalling Speed is minimum steady flight speed at which the aircraft is controllable with 50% flaps.
V_{SO}	Stalling Speed is the minimum steady flight speed at which the aircraft is controllable in the landing configuration (100% flaps) at the most unfavorable weight and balance.
V_X	Best Angle of Climb Speed is the speed at which the airplane will obtain the highest altitude in a given horizontal distance. The best angle-of-climb speed normally increases slightly with altitude.
V_Y	Best Rate of Climb Speed is the speed at which the airplane will obtain the maximum increase in altitude per unit of time. The best rate-of-climb speed decreases slightly with altitude.

Table 2: Meteorological Terminology

Meteorological Terminology	
Terminology	Definition
IMC	Instrument Meteorological Conditions are meteorological conditions expressed in terms of visibility, distance from cloud, and ceiling less than the minima for visual flight defined in 14 CFR 91.155.
ISA	International Standard Atmosphere (standard day) is an atmosphere where (1) the air is a dry perfect gas, (2) the temperature at sea level is 15 °C, (3) the pressure at sea level is 29.92 in.Hg (1013.2 millibars), and (4) the temperature gradient from sea level to the altitude at which the temperature is -56.5 °C is -0.00198 °C per foot and zero above that altitude.

Meteorological Terminology (Continued)	
Terminology	Definition
MSL	Mean Sea Level is the average height of the surface of the sea for all stages of tide. In this Handbook, altitude given as MSL is the altitude above the mean sea level. It is the altitude read from the altimeter when the altimeter's barometric adjustment has been set to the altimeter setting obtained from ground meteorological sources.
OAT	Outside Air Temperature is the free air static temperature obtained from in-flight temperature indications or from ground meteorological sources. It is expressed in either °C or °F.
PA	Pressure Altitude is the altitude read from the altimeter when the altimeter's barometric adjustment has been set to 29.92 in.Hg (1013.21 mb) corrected for position and instrument error. In this Handbook, altimeter instrument errors are assumed to be zero.
Standard Temperature	Standard Temperature is the temperature that would be found at a given pressure altitude in the standard atmosphere. It is 59 °F (15 °C) at sea level pressure altitude and decreases approximately 4 °F (2 °C) for each 1000 feet of altitude increase. See ISA definition.

Table 3: Engine Power Terminology

Engine Power Terminology	
Terminology	Definition
HP	Horsepower is the power developed by the engine.
MCP	Maximum Continuous Power is the maximum power that can be used continuously.
MAP	Manifold Pressure is the pressure measured in the engine's induction system expressed as in.Hg.
RPM	Revolutions Per Minute is engine rotational speed.
Static RPM	Static RPM is RPM attained during a full-throttle engine runup when the airplane is on the ground and stationary.

Table 4: Performance and Flight Planning Terminology

Performance and Flight Planning Terminology	
Terminology	Definition
g	One “g” is a quantity of acceleration equal to that of earth’s gravity.
Demonstrated Crosswind Velocity	Demonstrated Crosswind Velocity is the velocity of the crosswind component for which adequate control of the airplane during taxi, takeoff, and landing was demonstrated during certification testing. Demonstrated crosswind is not considered to be limiting.
Service Ceiling	Service Ceiling is the maximum altitude at which the aircraft at maximum weight has the capability of climbing at a rate of 100 feet per minute.
GPH	Gallons Per Hour is the amount of fuel (in gallons) consumed by the aircraft per hour.
NMPG	Nautical Miles Per Gallon is the distance (in nautical miles) which can be expected per gallon of fuel consumed at a specific engine power setting and/or flight configuration.
Unusable Fuel	Unusable Fuel is the quantity of fuel that cannot be safely used in flight.
Usable Fuel	Usable Fuel is the fuel available for flight planning.

Table 5: Weight and Balance Terminology

Weight and Balance Terminology	
Terminology	Definition
Reference Datum	Reference Datum is an imaginary vertical plane from which all horizontal distances are measured for balance purposes.
Tare	Tare is the weight of all items used to hold or position the airplane on the scales for weighing. Tare includes blocks, shims, and chocks. Tare weight must be subtracted from the associated scale reading.
Fuselage Station	Fuselage Station (FS) is a location along the airplane fuselage measured in inches from the reference datum and expressed as a number. For example: A point 123 inches aft of the reference datum is FS 123.
CG	Center of Gravity is the point at which an airplane would balance if suspended. Its distance from the reference datum is found by dividing the total moment by the total weight of the airplane.
Arm	Arm is the horizontal distance from the reference datum to the center of gravity (CG) of an item. The airplane's arm is obtained by adding the airplane's individual moments and dividing the sum by the total weight.
Moment	Moment is the product of the weight of an item multiplied by its arm.
Basic Empty Weight	Basic Empty Weight is the actual weight of the airplane including all operating equipment that has a fixed location in the airplane. The basic empty weight includes the weight of unusable fuel and full oil.
MAC	Mean Aerodynamic Chord is the chord drawn through the centroid of the wing plan area.
LEMAC	Leading Edge of Mean Aerodynamic Chord is the forward edge of MAC given in inches aft of the reference datum (fuselage station).

Weight and Balance Terminology (Continued)	
Terminology	Definition
Maximum Ramp Weight	Maximum Ramp Weight is the maximum weight approved for ground maneuver and includes the weight of the fuel used for startup and taxi.
Maximum Gross Weight	Maximum Gross Weight is the maximum permissible weight of the airplane and its contents as listed in the aircraft specifications.
Maximum Takeoff Weight	Maximum Takeoff Weight is the maximum weight approved for the start of the takeoff run.
Maximum Zero Fuel Weight	Maximum Zero Fuel Weight is the maximum permissible weight of the airplane and its contents minus the total weight of the fuel onboard.
Useful Load	Useful Load is the basic empty weight subtracted from the maximum ramp weight. It is the maximum allowable combined weight of pilot, passengers, fuel, and baggage.
Maximum Landing Weight	Maximum Landing Weight is the maximum weight approved for the landing touchdown.

Section 2: Limitations

Table of Contents

Introduction.....	3
Certification Status	3
Airspeed Limitations	4
Airspeed Indicator Markings	5
Powerplant Limitations	6
Engine	6
Fuel	7
Propeller	8
Hartzell	8
Weight Limits.....	8
Engine Instrument Markings & Annunciations.....	9
Powerplant	9
Fuel	10
Electrical.....	10
Center of Gravity Limits.....	11
Maneuver Limits	12
Flight Load Factor Limits	12
Minimum Flight Crew.....	12
Kinds of Operation.....	12
Kinds of Operation Equipment List.....	12
Icing.....	17
Runway Surface	17
Taxi Power	17
Fuel Limits.....	17
Altitude Limits	18
Environmental Conditions	18
Maximum Occupancy.....	18
Serials w/ 2+1 Rear Seat.....	18
Child Restraint System	18
Serials w/ Observer’s Seat	19
Child Restraint System	19
Serials w/o 2+1 Rear Seat or Observer’s Seat.....	19
Systems and Equipment Limits	20
Cirrus Perspective+ Integrated Avionics System	20
L-3 Stormscope Weather Information System (Optional).....	23
Max Viz Enhanced Vision System (Optional).....	23

MD302 Standby Attitude Module (Optional)	24
Air Conditioning System (Optional)	24
Inflatable Restraint System.....	24
Flap Limitations	24
Paint	24
Cirrus Airframe Parachute System (CAPS).....	24
Other Limitations	24
Smoking.....	24
Crew Communication	24
Placards.....	25

Introduction

The limitations included in this Section of the Pilot's Operating Handbook (POH) are approved by the Federal Aviation Administration.

This section provides operating limitations, instrument markings, and basic placards required by regulation and necessary for the safe operation of the aircraft and its standard systems and equipment.

• Note •

Compliance with the operating limitations in this section and in Section 9 is required by Federal Aviation Regulations.

Limitations associated with optional equipment are not described in this section. Refer to [Section 9: Log of Supplements](#) of this handbook for amended operating limitations for airplanes equipped with optional equipment.

Certification Status

The aircraft is certificated under the requirements of 14 CFR, Part 23 as documented by FAA Type Certificate TC AT00009CH-A.

Airspeed Limitations

The indicated airspeeds in the following table are based on Section 5, [Airspeed Calibration](#) - Normal Static Source Table. When using the alternate static source, allow for the airspeed calibration variations between the normal and alternate static sources.

Speed	KIAS	KCAS	Remarks
V_{NE}	201	204	Never Exceed Speed is the speed limit that may not be exceeded at any time.
V_{NO}	164	166	Maximum Structural Cruising Speed is the speed that should not be exceeded except in smooth air, and then only with caution.
V_O 3150 Lb	133	135	Operating Maneuvering Speed is the maximum speed at which full control travel may be used. Below this speed the airplane stalls before limit loads are reached. Above this speed, full control movements can damage the airplane.
V_{FE} 50% Flaps 100% Flaps	150 110	152 111	Maximum Flap Extended Speed is the highest speed permissible with wing flaps extended.
V_{PD}	133	135	Maximum Demonstrated Parachute Deployment Speed is the maximum speed at which parachute deployment has been demonstrated.

Airspeed Indicator Markings

The airspeed indicator markings are based on Section 5, [Airspeed Calibration](#) - Normal Static Source Table. When using the alternate static source, allow for the airspeed calibration variations between the normal and alternate static sources.

Marking	Value (KIAS)	Remarks
White Arc	62 - 110	Full Flap Operating Range. Lower limit is the most adverse stall speed in the landing configuration. Upper limit is the maximum speed permissible with flaps extended.
Green Arc	71 - 164	Normal Operating Range. Lower limit is the maximum weight stall at most forward C.G. with flaps retracted. Upper limit is the maximum structural cruising speed (V_{NO}).
Yellow Arc	164 - 201	Caution Range. Operations must be conducted with caution and only in smooth air.
Red Arc	201	Never Exceed Speed (V_{NE}). Maximum speed for all operations.

Powerplant Limitations

Engine

Lycoming Engines..... IO-390-C3B6
Power Rating 215 HP @ 2700 RPM
Maximum RPM2700 RPM

• NOTE •

Due to the mechanical design of the propeller governor, it is normal for the engine to temporarily exceed 2700 RPM during some phases of flight. If necessary, a slight reduction in throttle setting will decrease the RPM to keep the engine operating at or below 2700 RPM.

Power Lever MovementGREATER THAN 3 SECONDS FOR FULL RANGE

• NOTE •

Abrupt full range power lever movement can result in engine damage. Idle to maximum power movements of the power lever should be made slowly (approximately 3 seconds for full range motion).

Oil Temperature..... 235 °F (113 °C) maximum
Minimum Oil Temperature for Takeoff..... 100 °F (38 °C)

Oil Pressure:

Minimum (Idling)25 psi
Normal Operating Range..... 55 - 95 psi
Maximum (Starting, Warm up, Taxi, & Takeoff)115 psi

Approved Oils:

Engine Break-In: For first 50 hours of operation or until oil consumption stabilizes, use straight mineral oil conforming to SAE J1966 or MIL-L-6082B SAE grades. If engine oil must be added to the factory-installed oil, add only SAE J1966 or MIL-L-6082B straight mineral oil.

After Engine Break-In: Use only oils conforming to SAE J1899 or MIL-L-22851 Ashless Dispersant SAE grades.

Recommended Oil Grades^a				
Ambient Air Temperature (SL)	Engine Break-In		After Engine Break-In	
	Single Viscosity	Multi-Viscosity	Single Viscosity	Multi-Viscosity
All Temperatures	-	-	-	SAE 15W-50 SAE 20W-50
Above 80 °F (27 °C)	SAE 60	-	SAE 60	-
Above 60 °F (16 °C)	SAE 50	-	SAE 40 SAE 50	-
30 °F (-1 °C) to 90 °F (32 °C)	SAE 40	-	SAE 40	-
0 °F (-18 °C) to 70 °F (21 °C)	SAE 30	-	SAE 30 SAE 40	SAE 20W-40
Below 10 °F (-12 °C)	SAE 20	-	SAE 20 SAE 30	SAE 20W-30

a. For additional qualified oil grades and viscosities, refer to the Lycoming Service Instruction No. 1014.

• NOTE •

The correct grade of oil to be used is based on environmental conditions. If the aircraft is going to be flown into an area that is much warmer or colder than the aircraft is usually operated in, use a different viscosity of oil.

During operation, if the oil inlet temperatures are near the maximum permitted temperatures, then a higher viscosity oil can help to decrease the temperatures.

Fuel

Fuel Grade Aviation Grade 100 LL (Blue) or 100 (Green)

• NOTE •

Refer to [Fuel Limits](#) in this Section regarding fuel and fuel storage.

Propeller

Hartzell

Propeller Type Constant Speed

Three-Blade Propeller, Metal (Standard):

Model Number HC-E3YR-1RF/F7392S-1

Diameter 74.0" (73.0" Minimum)

• **WARNING** •

Failure to comply with the shot peening requirement described below may cause damaging loads on the propeller hub, blades and/or pitch change system that can lead to propeller failure.

The metal propeller blades must be shot peened between stations 6.0 and 22.0 on both face and camber sides. Blades having damage to the shot peened areas exceeding 0.015 inch deep (including material removal necessary to blend out such damage) must be removed from service and the reworked area shot peened before further flight.

• **NOTE** •

For leading and trailing edge damage, a 0.250 inch deep rework limit applies before shot peening is required. Reference Hartzell Propeller Owner's Manual No. 115(N).

Three-Blade Propeller, Composite (Optional):

Model Number 3C1-R919A1/76C03-2

Diameter 74.0" Minimum

Weight Limits

Maximum Takeoff Weight 3150 lb (1429 kg)

Maximum Landing Weight 3150 lb (1429 kg)

Maximum Weight in Baggage Compartment 130 lb (59 kg)

Engine Instrument Markings & Annunciations

The following describes the engine instrument markings.

Powerplant

Instrument (Range & Units)	Red Arc/Bar	Yellow Arc/Bar	Green Arc/Bar	Yellow Arc/Bar	Red Arc/Bar
	Lower Warning Range	Min. Caution Range	Normal Range	Max. Caution Range	Upper Warning Range
Cylinder Head Temperature (100 °F – 500 °F)	--	--	240 – 435	435 – 465	> 465
Engine Speed (0 – 3000 RPM)	--	--	500 – 2700	--	> 2700 ^a
Exhaust Gas Temperature (500 °F – 1750 °F)	--	--	1000–1600	--	--
Manifold Pressure (10 – 35 Inch Hg)	--	--	15 – 29.5	--	--
Oil Pressure (0 – 115 PSI)	0 – 25 ^b	25 – 55 ^b	55 – 95	95 – 115	> 115 ^b
Oil Temperature (75 °F – 250 °F)	--	--	100 – 235	--	> 235
Percent Power (0 – 100%)	--	--	0 – 100	--	--

- a. Engine Speed Warning when RPM between 2710 and 2730 for more than 10 seconds OR when RPM greater than 2730 for more than 5 seconds.
- b. Oil Pressure Caution when oil pressure is between 25 and 54 psi and RPM is greater than 1000. Oil Pressure Warning when oil pressure is below 25 psi, OR oil pressure is above 115 psi.

Fuel

Instrument (Range & Units)	Red Arc/Bar	Yellow Arc/Bar	Green Arc/Bar	Yellow Arc/Bar	Red Arc/Bar
	Minimum	Minimum Caution Range	Normal Range	Maximum Caution Range	Maximum
Fuel Flow (0 – 25 U.S. Gal/Hr)	--	--	0 – 21 ^a	--	--
Fuel Totalizer (U.S. Gallon)	< 7	7 – 10	> 10	--	--
Fuel Quantity (0 – 28 U.S. Gallon)	0	0 – 10	10 – 28	--	--

a. Top of green arc dynamically changes based on altitude.

Electrical

Instrument (Range & Units)	Red Arc/Bar	Yellow Arc/Bar	Green Arc/Bar	Yellow Arc/Bar	Red Arc/Bar
	Minimum	Minimum Caution Range	Normal Range	Maximum Caution Range	Maximum
Essential Bus Volts (0 – 36 Volts)	0 – 24.4	--	24.5 – 32	--	> 32
Main Bus 1 Voltage (0 – 36 Volts)	--	0 – 24.4	24.5 – 32	--	> 32
Main Bus 2 Voltage (0 – 36 Volts)	--	0 – 24.4	24.5 – 32	--	> 32
Alternator 1 Current (0 – 100 Amps)	--	--	2 – 100	0 – 1 ^a	--
Alternator 2 Current (0 – 70 Amps)	--	--	2 – 100	0 – 1 ^a	--
Battery 1 Current (-59 to 59 Amps)	--	--	-4 – 59	-59 to -5 ^b	--

a. 20 second delay.

b. 30 second delay.

Center of Gravity Limits

Reference Datum 100 inches forward of firewall

Forward..... Refer to [Figure 2-1](#)

Aft Refer to [Figure 2-1](#)

Figure 2-1: Center of Gravity Envelope

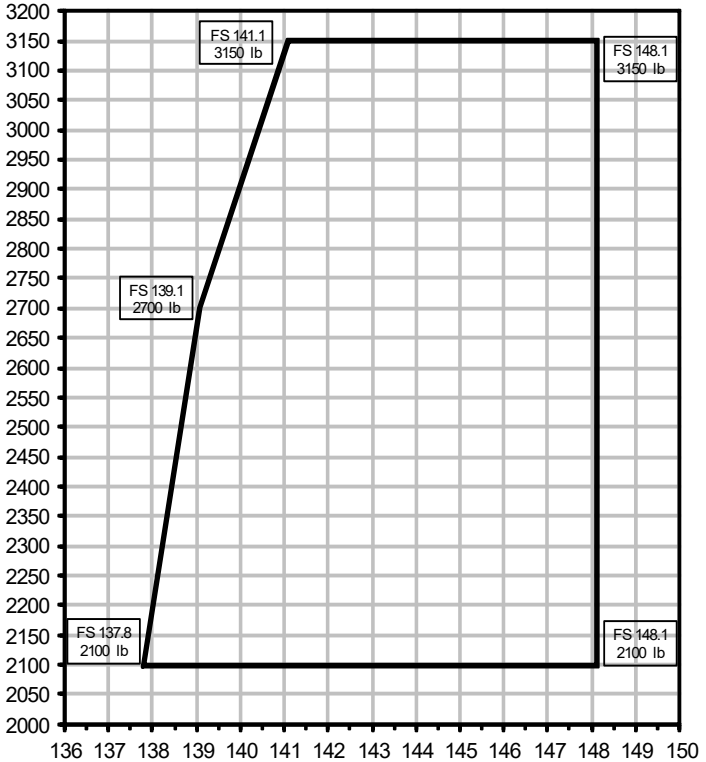

Maneuver Limits

Acrobatic maneuvers are prohibited.

Spins are prohibited.

• NOTE •

Because the aircraft has not been certified for spin recovery, the Cirrus Airframe Parachute System (CAPS) must be deployed if the airplane departs controlled flight. Refer to Section 3, [Inadvertent Spin Entry](#).

Flight Load Factor Limits

Flaps UP (0%), 3150 lb	+3.8g, -1.9g
Flaps 50%, 3150 lb.....	+1.9g, 0g
Flaps 100% (Down), 3150 lb.....	+1.9g, 0g

Minimum Flight Crew

The minimum flight crew is one pilot.

Kinds of Operation

The aircraft is equipped and approved for the following type operations:

- VFR day and night.
- IFR day and night.

Kinds of Operation Equipment List

The following listing summarizes the equipment required under Code of Federal Regulations (CFR) Part 23 for airworthiness under the “listed kind of operation”. Those minimum items of equipment necessary under the operating rules are defined in 14 CFR Part 91.

• NOTE •

All references to types of flight operations on the operating limitations placards are based upon equipment installed at the time of Airworthiness Certificate issuance.

System, Instrument and/or Equipment	Kinds of Operation				Remarks, Notes, and/or Exceptions
	VFR Day	VFR Night	IFR Day	IFR Night	
PLACARDS AND MARKINGS					
Airplane Flight Manual (Included w/ POH)	1	1	1	1	
COMMUNICATIONS					
VHF COM	-	-	1	1	
ELECTRICAL POWER					
Battery 1	1	1	1	1	
Battery 2	-	-	1	1	
Alternator 1	1	1	1	1	
Alternator 2	-	-	1	1	
Amp Meter/Indication	1	1	1	1	
Low Volts Annunciator	1	1	1	1	
ALT 1 Annunciator	1	1	1	1	
ALT 2 Annunciator	-	-	1	1	
Circuit Breakers	A/R	A/R	A/R	A/R	As required.
EQUIPMENT & FURNISHINGS					
Emergency Locator Transmitter	1	1	1	1	
Restraint System	A/R	A/R	A/R	A/R	One seat belt for each occupant.
FIRE PROTECTION					
Fire Extinguisher	1	1	1	1	
FLIGHT CONTROLS					
Flap Position Indicator	1	1	1	1	
Flap System	1	1	1	1	

System, Instrument and/or Equipment	Kinds of Operation				Remarks, Notes, and/or Exceptions
	VFR Day	VFR Night	IFR Day	IFR Night	
Pitch Trim Indicator	1	1	1	1	
Pitch Trim System	1	1	1	1	
Roll Trim Indicator	1	1	1	1	
Roll Trim System	1	1	1	1	
Stall Warning System	1	1	1	1	
FUEL					
Emergency Boost Pump	1	1	1	1	
Fuel Quantity Indicators	2	2	2	2	
Fuel Selector Valve	1	1	1	1	
ICE & RAIN PROTECTION					
Alternate Engine Air Induction System	1	1	1	1	
Alternate Static Air Source	1	1	1	1	
Pitot Heater	-	-	1	1	
LANDING GEAR					
Wheel Pants	-	-	-	-	May be removed.
LIGHTS					
PFD Bezel Lighting	-	-	-	1	
PFD Backlighting	*	1	1	1	*Required if MFD Backlighting Fails. Engine Indicators Must Be Shown in Backup Mode.
MFD Bezel Lighting	-	-	-	1	

System, Instrument and/or Equipment	Kinds of Operation				Remarks, Notes, and/or Exceptions
	VFR Day	VFR Night	IFR Day	IFR Night	
MFD Backlighting	*	1	1	1	*Required if PFD Backlighting Fails. Engine Indicators Must Be Shown in Backup Mode.
Anticollision Lights	2	2	2	2	
Instrument Lights	-	1	-	1	
Navigation Lights	-	2	-	2	
Landing Light	-	1	-	1	For hire operations.
Flash Light	-	1	-	1	
NAVIGATION & PITOT STATIC					
Airspeed Indicator	1	1	1	1	
Altimeter	1	1	1	1	
Magnetic Compass	1	1	1	1	* For serials 2650 and subs: Magnetic compass is not required equipment unless specifically required by operating rules or validating certification authorities.
Pitot System	1	1	1	1	
Static System, Normal	1	1	1	1	
Attitude Indicator	-	-	1	1	
Clock	-	-	1	1	
Gyroscopic Directional Indication (HSI)	-	-	1	1	
Magnetometer	-	-	1	1	

System, Instrument and/or Equipment	Kinds of Operation				Remarks, Notes, and/or Exceptions
	VFR Day	VFR Night	IFR Day	IFR Night	
Nav Radio	-	-	1	1	
PFD Airspeed Indication	-	-	1	1	
PFD Altitude Indication	-	-	1	1	
PFD Attitude Indication	-	-	1	1	
PFD Heading Indication	-	-	1	1	
PFD Slip/Skid Indication	-	-	1	1	
Turn Coordinator	-	-	1	1	
Altitude Encoder	A/R	A/R	1	1	As required per procedure.
GPS Receiver/Navigator	-	-	A/R	A/R	As required per procedure.
Marker Beacon Receiver	-	-	A/R	A/R	As required per procedure.
VHF Navigation Radio	-	-	A/R	A/R	As required per procedure.
Vertical Speed Indicator	-	-	-	-	
ENGINE INDICATING					
Cylinder Head Temperature Indication	-	-	-	-	
Exhaust Gas Temperature Indication	-	-	-	-	
Fuel Flow Indication	1	1	1	1	

System, Instrument and/or Equipment	Kinds of Operation				Remarks, Notes, and/or Exceptions
	VFR Day	VFR Night	IFR Day	IFR Night	
Manifold Pressure Indication	1	1	1	1	
Oil Pressure Indication	1	1	1	1	
Oil Quantity Indicator (Dipstick)	1	1	1	1	
Oil Temperature Indication	1	1	1	1	
Engine Speed	1	1	1	1	
SPECIAL EQUIPMENT					
Cirrus Airframe Parachute (CAPS)	1	1	1	1	

Icing

Flight into known icing conditions is prohibited.

Runway Surface

This airplane may be operated on any smooth runway surface.

Taxi Power

Maximum continuous engine speed for taxiing is 1000 RPM on flat, smooth, hard surfaces. Power settings slightly above 1000 RPM are permissible to start motion, for turf, soft surfaces, and on inclines. Use minimum power to maintain taxi speed.

Fuel Limits

Approved Fuel..... Aviation Grade 100 LL (Blue) or 100 (Green)
 Total Fuel Capacity58.5 U.S. gallons (221.4 L)
 Total Fuel Each Tank29.3 U.S. gallons (110.9 L)
 Total Usable Fuel (all flight conditions).....56.0 U.S. gallons (212.0 L)
 Maximum Allowable Fuel Imbalance.....7.5 U.S. gallons (28.4 L)
 The fuel pump must be set to ON for takeoff, climb, maneuvering flight, landing, and for switching fuel tanks.

Altitude Limits

Maximum Takeoff Altitude.....10,000 ft MSL

Maximum Operating Altitude17,500 ft MSL

The operating rules (CFR Part 91 and CFR Part 135) require the use of supplemental oxygen at specified altitudes below the maximum operating altitude.

Environmental Conditions

Do not operate the airplane below an outside air temperature of -40 °F (-40 °C).

Maximum Occupancy

Serials w/ 2+1 Rear Seat

Occupancy of this airplane is limited to “4+1” persons, the pilot and four passengers. If carrying three rear seat passengers, occupants must be wearing a seat belt and shoulder harness with their hips and back firmly against the seat back as shown in the following illustration. If three rear seat passengers cannot meet these requirements, occupancy is limited to four persons.

Child Restraint System

1. Rear seat configuration for LATCH / ISOFIX compliant child seats is limited to two seats in the outboard positions.
2. A single non-LATCH / ISOFIX compliant seat may be installed in the center seat position.
3. Installation of three child seats in the rear seat is prohibited.

Figure 2-2: Rear Passenger Seat Arrangement

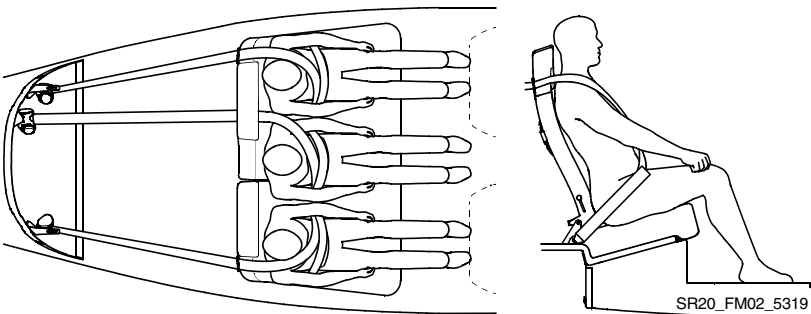

Serials w/ Observer's Seat

Occupancy of this airplane is limited to three persons, the pilot and two passengers.

Child Restraint System

1. Rear seat configuration for LATCH / ISOFIX compliant child seat is limited to the Observer's Seat.

Figure 2-3: Observer's Seat Arrangement

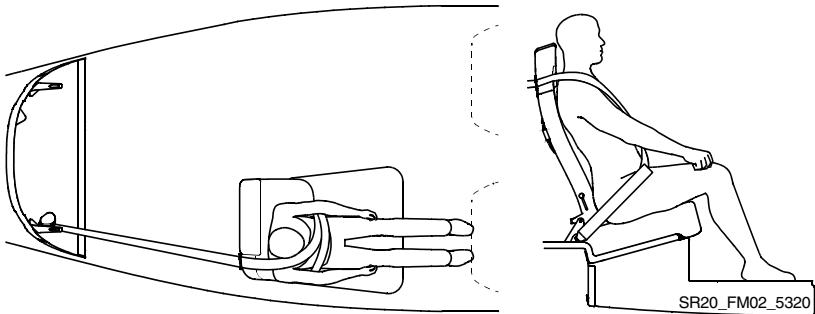

Serials w/o 2+1 Rear Seat or Observer's Seat

1. Occupancy of this airplane is limited to two persons, the pilot and one passenger.
 2. Installation of child seat is prohibited.
- Refer to Section 7, [Seats](#) for additional information.

Systems and Equipment Limits

Cirrus Perspective+ Integrated Avionics System

1. The appropriate revision of the Cirrus Perspective+ Cockpit Reference Guide (p/n 190-02184-XX, where X can be any digit from 0 to 9) must be immediately available to the pilot during flight. The system software version stated in the reference guide must be appropriate for the system software version displayed on the equipment.
2. The Avionics System integrates with separately approved sensor installations. Adherence to limitations in appropriate installation POH supplements is mandatory.
3. IFR enroute and terminal navigation is prohibited unless the pilot verifies the currency of the database or verifies each selected waypoint for accuracy by reference to current approved data.
4. Instrument approach navigation predicated upon the GPS Receiver must be accomplished in accordance with approved instrument approach procedures that are retrieved from the GPS equipment database. The GPS equipment database must incorporate the current update cycle.
 - a) Receiver Autonomous Integrity Monitoring (RAIM) must be available at the Final Approach Fix for instrument approach procedures that do not use the integrity information from Satellite Based Augmentation Systems (SBAS). For flight planning purposes, in areas where SBAS coverage is not available, the pilot must check RAIM availability.
 - b) Accomplishment of ILS, LOC, LOC-BC, LDA, SDF, MLS or any other type of approach not approved for GPS overlay with the GPS receiver is not authorized.
 - c) Use of the VOR/ILS receiver to fly approaches not approved for GPS requires VOR/ILS navigation data to be present on the display.
 - d) Vertical Navigation information for approach procedures that do not meet the ICAO Annex 10 requirements for precision approaches may be utilized for advisory information only. Use of Vertical Navigation information for Instrument Approach Procedures does not guarantee step-down fix altitude protection, or arrival at approach minimums in normal position to land.
 - e) IFR non-precision approach approval is limited to published approaches within the U.S. National Airspace System. Approaches to

- airports in other airspace are not approved unless authorized by the appropriate governing authority.
- f) RNAV approaches must be conducted utilizing the GPS sensor.
 - g) The Perspective+ Integrated Avionics System is compliant with AC 90-100A. As such, the Cirrus Perspective+ system is eligible to fly RNAV 'Q' or 'T' routes, RNAV SID/STAR/ODPs and eligible to use RNAV substitution or RNAV alternate means of navigation (US Only). Refer to AC 90-100A for additional operator requirements and limitations.
 - h) The Perspective+ Integrated Avionics System includes navigation sensors that meet the standards set forth in TSOC145d (Sensors) and (Display Units) for Class 3 systems.
 - i) The Perspective+ Integrated Avionics System has been installed in accordance with AC 20-138A and is approved for navigation using GPS and SBAS (within the coverage of a Satellite Based Augmentation System complying with ICAO annex 10) for IFR enroute, terminal and approach operations.
 - j) The Perspective+ Integrated Avionics System complies with the standards set forth in AC 90-96A and JAA TGL-10 (rev 1) for BRNAV and PRNAV operations.
 - k) The navigation databases employed by the Perspective+ Integrated Avionics System meet the requirements set forth in AC 20-153 for database integrity, quality and database management practices. The data in the navigation databases are referenced to the WGS-84 reference system.
 - l) The Perspective+ Integrated Avionics System complies with the standards set forth in AMC 20-27 and NPA 2009-04 (AMC 20-28) for RNAV operations including LNAV/VNAV and LPV approach operations.
 - m) Barometric vertical navigation (Baro-VNAV) operations may be conducted if SBAS is unavailable or disabled. The Perspective+ Integrated Avionics System will provide automatic, temperature-compensated glidepath vertical guidance and has been shown to meet the accuracy requirements of VFR/IFR enroute, terminal, and approach Baro-VNAV operations within the conterminous US and Alaska in accordance with the criteria in AC 20-138D.

5. Navigation using the Perspective+ Integrated Avionics System is not authorized in the following geographic areas:
 - a) north of 70° North latitude (northern polar region),
 - b) south of 70° South latitude (southern polar region),
 - c) north of 65° North latitude between longitude 75°W and 120°W (Northern Canada),
 - d) south of 55° South latitude between longitude 120°E and 165°E (region south of Australia and New Zealand).
6. The MFD checklist display supplements the Pilot Operating Handbook checklists and is advisory only. Use of the MFD checklists as the primary set of on-board airplane checklists is prohibited.
7. The NAVIGATION MAP is intended only to enhance situational awareness. Use of the NAVIGATION MAP page for pilotage navigation is prohibited.
8. Do not use SAFETAXI or CHARTVIEW functions as the basis for ground maneuvering. SAFETAXI and CHARTVIEW functions have not been qualified to be used as an Airport Moving Map Display (AMMD). SAFETAXI and CHARTVIEW are to be used by the flight crew to orient themselves on the airport surface to improve pilot situational awareness during ground operations.
9. The TERRAIN PROXIMITY MAP is intended only to enhance situational awareness. Use of the TERRAIN PROXIMITY information for primary terrain avoidance is prohibited.
10. LTNG information on the NAVIGATION MAP or WEATHER MAP is approved only as an aid to hazardous weather avoidance. Use of the WEATHER MAP for hazardous weather penetration is prohibited.
11. The SYNTHETIC VISION SYSTEM (SVS) cannot be used for flight guidance, navigation, traffic avoidance, or terrain avoidance. Maneuvering the airplane in any phase of flight such as taxi, takeoff, approach, landing, or roll out shall not be predicated on SVS imagery. The synthetic vision system is not intended to be used independently of traditional attitude instrumentation. Consequently, SVS is disabled when traditional attitude instrumentation is not available. Otherwise, the traditional attitude instrumentation will always be visible in the foreground with SVS features in the background.
12. Use of the TRAFFIC ADVISORY SYSTEM (TAS) to maneuver the airplane to avoid traffic is prohibited. The TAS is intended for advisory use only. TAS is intended only to help the pilot to visually locate traffic. It is the responsibility of the pilot to see and maneuver to avoid traffic.

13. The installed ADS-B OUT system, including GTX 335 Mode S Transponder and GTX 345 Mode S UAT in Transponder (optional), has been shown to meet the equipment requirements of 14 CFR 91.227.
14. FIS-B Receiver Equipment, including GTX 345 Mode S UAT in Transponder (optional):
 - a) Flight Information Services - Broadcast (FIS-B) information is intended to enhance pilot awareness of weather and airspace conditions. It does not replace positive two way communication when making safety critical weather or routing decisions. Use FIS-B weather and National Airspace System (NAS) status information as follows:
 - (1) To aid pilot awareness of hazardous meteorological conditions and awareness of the regulatory status of the airspace.
 - (2) FIS-B information is meant to enhance flight planning only. It lacks sufficient resolution and updating necessary for tactical maneuvering.

L-3 Stormscope Weather Information System (Optional)

1. Use of the Weather Information System is not intended for hazardous weather penetration (thunderstorm penetration). Weather information, as displayed on the Perspective+ Integrated Avionics System, is to be used only for weather avoidance, not penetration.
2. When option installed, the appropriate revision of the L-3 Avionics Systems WX500 Stormscope Series II Weather Mapping Sensor User's Guide, (p/n 009-11501-001) must be available to the pilot during flight.

Max Viz Enhanced Vision System (Optional)

1. The Enhanced Vision System (EVS) cannot be used for flight guidance, navigation, traffic avoidance, or terrain avoidance. Maneuvering the airplane in any phase of flight such as taxi, takeoff, approach, landing, or roll out shall not be predicated on EVS imagery. The EVS shall only be used as an aid to assist the flight crew to visually acquire objects normally viewed through the cockpit windows.
2. The appropriate revision of the Max Viz Enhanced Vision System Information Manual, (p/n 309100024) must be available to the pilot during flight.

MD302 Standby Attitude Module (Optional)

1. Selection of the option menu of the MD302 is limited to ground or visual meteorological conditions.
2. The display has an operational lower temperature limit of -22 °F (-30 °C). Visibility of the display may be reduced between -4 °F (-20 °C) and -22 °F (-30 °C).
3. The appropriate revision of the Mid-Continent Instruments and Avionics MD302 Standby Attitude Module Pilot's Guide (p/n 9017846) must be available to the pilot whenever the system is in use.

Air Conditioning System (Optional)

The use of Recirculation Mode during flight is prohibited.

Inflatable Restraint System

Use of a child safety seat with inflatable restraint system is prohibited.

Flap Limitations

Approved Takeoff Settings50%
Approved Landing Settings0%, 50%, or 100%

Paint

To ensure that the temperature of the composite structure does not exceed 150 °F (66 °C), the outer surface of the airplane must be painted in accordance with the paint colors and schemes as specified in the Airplane Maintenance Manual. Refer to Airplane Maintenance Manual (AMM), Chapter 51, for specific paint requirements.

Cirrus Airframe Parachute System (CAPS)

V_{PD} Maximum Demonstrated Deployment Speed 133 KIAS

• NOTE •

Refer to Section 10, [Cirrus Airframe Parachute System \(CAPS\)](#) for additional CAPS guidance.

Other Limitations

Smoking

Smoking is prohibited in this airplane.

Crew Communication

One headset which satisfies the requirements of TSO C139() or a microphone which satisfies the requirements of TSO C58 must be available for pilot use when operations require two-way communications.

Placards

Figure 2-4: Placards (1 of 6)

Engine compartment, inside oil filler access:

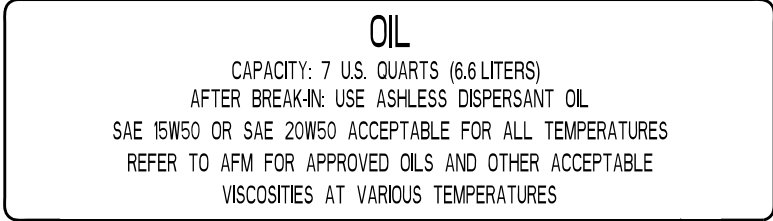

Wing, adjacent to fuel filler caps:

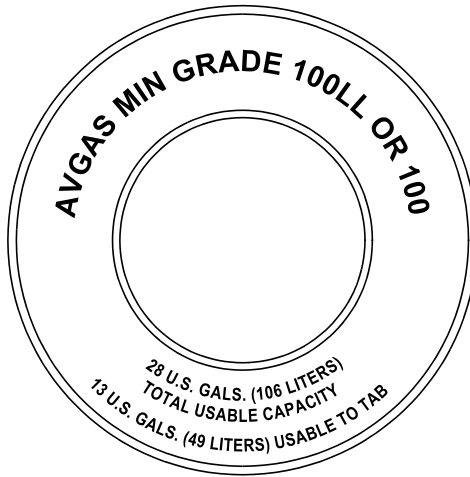

Upper fuselage, either side of CAPS rocket cover:



SR20_FM02_5410

Figure 2-4: Placards (2 of 6)

Left fuselage, on external power supply door:

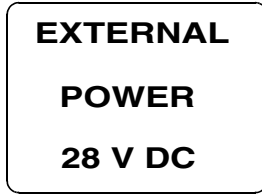

Doors, adjacent to latch:

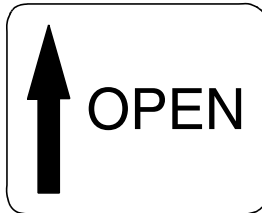
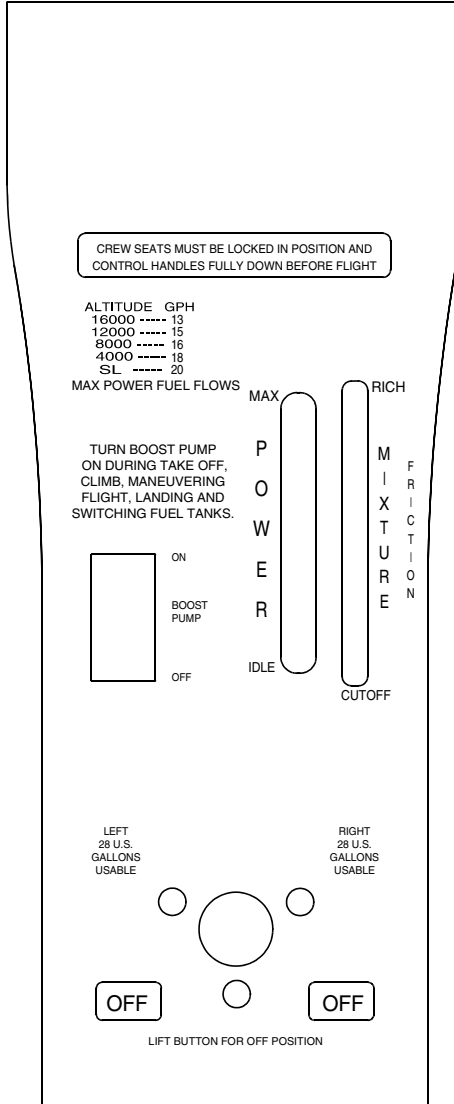

Figure 2-4: Placards (3 of 6)

Engine control panel:



SR20_FM02_5412

Figure 2-4: Placards (4 of 6)

Cabin Door Window, lower edge, centered, applied upside down:

RESCUE: FRACTURE AND REMOVE WINDOW

Bolster Switch Panel, left edge:

**THIS AIRCRAFT IS CERTIFIED FOR THE
FOLLOWING FLIGHT OPERATIONS:
DAY - NIGHT - VFR - IFR
(WITH REQUIRED EQUIPMENT)
FLIGHT INTO KNOWN ICING IS PROHIBITED
OPERATE PER AIRPLANE FLIGHT MANUAL**

Instrument Panel, left :

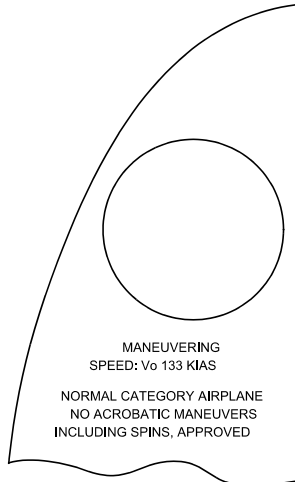

Figure 2-4: Placards (5 of 6)

Instrument Panel, center:

**DISPLAY
BACKUP**

Baggage Compartment, aft edge:

**ELT LOCATED BEHIND BULKHEAD
REMOVE CARPET AND ACCESS PANEL**

Instrument Panel:

**FASTEN SEATBELTS • NO SMOKING
FIRE EXTINGUISHER FORWARD LEFT OF PILOT SEAT**

Cabin Window, above door latch:

**EMERGENCY EXIT
REMOVE EGRESS HAMMER FROM WITHIN
CENTER ARMREST LID. STRIKE CORNER OF
WINDOW. KICK OR PUSH OUT AFTER FRACTURING**

Baggage Compartment Door, inside:

**DISTRIBUTED FLOOR LIMIT 130 LBS
BAGGAGE STRAP CAPACITY IS 35 LBS EACH MAXIMUM
SEE AIRPLANE FLIGHT MANUAL FOR BAGGAGE TIE-DOWN
AND WEIGHT AND BALANCE INFORMATION**

SR20_FM02_5414A

Figure 2-4: Placards (6 of 6)

CAPS Deployment Handle Cover, above pilot's right shoulder:

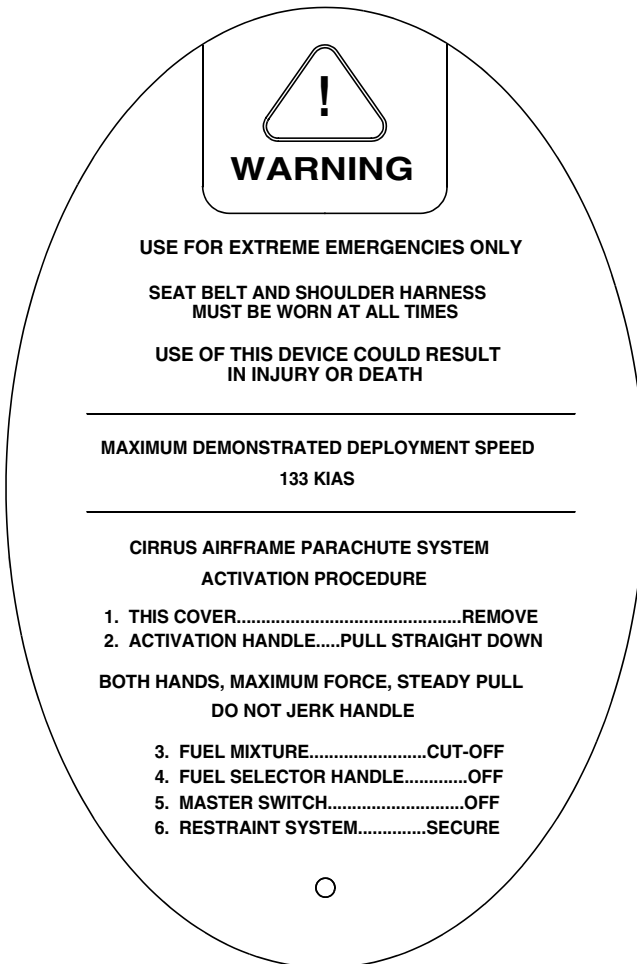

SR20_FM02_5415

Section 3: Emergency Procedures

Table of Contents

Introduction.....	3
Crew Alert System (CAS) Messaging	3
Warnings	3
CAPS Guidance	3
Preflight Planning	4
Preflight Inspections/Maintenance	4
Methodology	4
Maintain Aircraft Control	4
Analyze the Situation	4
Take Appropriate Action	5
Land as Soon as Conditions Permit	5
Circuit Breakers	5
Memory Items	6
Procedure Division Symbols	6
Landing Guidance	6
Land as Soon as Practicable	6
Land as Soon as Possible	7
Airspeeds for Emergency Operations	8
Maneuvering Speed	8
Best Glide (Flaps: UP)	8
Emergency Landing	8
Engine Failures	9
Engine Failure On Takeoff - Low Altitude	9
Engine Failure In Flight	10
Airstart	11
Engine Airstart	11
Smoke and Fire	12
Cabin Fire In Flight	12
Engine Fire In Flight	13
Wing Fire In Flight	14
Engine Fire During Start	14
Smoke and Fume Elimination	15
Emergency Descent	15
Glide	16
Best Glide Speed	16
Forced Landings	17

Emergency Landing w/o Power.....	17
Ditching.....	18
Landing Without Elevator Control.....	18
Engine System Emergencies	19
Engine Partial Power Loss	19
OIL PRESS Warning	21
OIL TEMP Warning	21
CHT Caution and Warning	22
Propeller System Emergencies	23
RPM Warning	23
Propeller Governor Failure	23
Propeller RPM Will Not Increase	23
Propeller Overspeeds or Will Not Decrease	23
Fuel System Emergencies.....	24
FUEL LOW LEFT Warning	24
FUEL LOW RIGHT Warning.....	24
FUEL LOW TOTAL Warning	25
FUEL IMBALANCE Warning	25
Electrical System Emergencies.....	26
M BUS 1 Warning.....	26
M BUS 2 Warning.....	27
ESS BUS Warning.....	28
Environmental System Emergencies.....	29
CO LVL HIGH Warning	29
Integrated Avionics System Emergencies.....	30
Attitude & Heading Reference System (AHRS) Failure.....	30
Air Data Computer (ADC) Failure.....	30
PFD Display Failure.....	31
Unusual Attitude Emergencies	31
Inadvertent Spin Entry	31
SPIN SPIN SPIN Warning	32
Inadvertent Spiral Dive During IMC Flight	33
Other Emergencies.....	34
Power Lever Linkage Failure.....	34
Emergency Engine Shutdown On Ground	34
BRAKE TEMP Warning.....	35
START ENGAGED Warning	35
Emergency Ground Egress	37
CAPS Deployment.....	38

Smoke and Fire

Cabin Fire In Flight

Added warning following fire extinguisher activation step.

• WARNING •

Serials w/ Halotron fire extinguisher: The fire extinguisher should only be used in one second blasts. If the fire is not extinguished following one second blasts, use as required to extinguish the fire. Inhalation of the complete discharge of the fire extinguisher may result in cardiotoxicity and/or anesthetic effects to the occupants.

Intentionally Left Blank

Introduction

This section provides procedures for handling emergencies and critical flight situations that may occur while operating the aircraft. Although emergencies caused by airplane, systems, or engine malfunctions are rare, the guidelines described in this section should be considered and applied as necessary should an emergency arise.

Emergency procedures associated with optional equipment are not described in this section.

Although this section provides procedures for handling most emergencies and critical flight situations that could arise in the aircraft, it is not a substitute for proper flight training, thorough knowledge of the airplane, and recognized piloting techniques and standards. A thorough study of the information in this handbook while on the ground will help you prepare for time-critical situations in the air.

• NOTE •

Refer to [Section 9: Log of Supplements](#) for optional equipment Emergency Procedures.

Crew Alert System (CAS) Messaging

Warnings

Displayed in red against a black background, Warning CAS messages arise during emergency situations that require immediate flight crew awareness and immediate flight crew response.

- A flashing Warning CAS message with an accompanying aural alert requires immediate action.
- A Warning CAS message with no accompanying aural alert requires attention, dependent on workload. It may also require performing maintenance or taking corrective action prior to next flight. Warnings with no aural alert typically occur while on ground.

• NOTE •

Crew Alerting System messages and related procedures described herein assume the aircraft is equipped with Garmin System Software 2647.N4 or later.

CAPS Guidance

All Cirrus aircraft are equipped with a pilot or passenger activated ballistic airframe parachute system. The system is capable of lowering the aircraft and occupants safely to the ground for life threatening emergencies. CAPS provides pilots and passengers an alternative means of handling various life threatening emergency situations. In many cases CAPS may offer a safer

option for occupants as compared to continued flight or traditional countermeasures. Pilots flying Cirrus aircraft must be properly trained and familiar with CAPS guidance, limitations, and operating procedures. Refer to Section 10, [Cirrus Airframe Parachute System \(CAPS\)](#), for CAPS deployment and guidance information.

Preflight Planning

Enroute emergencies caused by weather can be minimized or eliminated by careful flight planning and good judgment when unexpected weather is encountered.

Preflight Inspections/Maintenance

In-flight mechanical problems in the aircraft will be extremely rare if proper preflight inspections and maintenance are practiced. Always perform a thorough walk-around inspection before any flight to ensure that no damage occurred during the previous flight or while the airplane was on the ground. Pay special attention to any oil leaks or fuel stains that could indicate engine problems.

• NOTE •

Refer to [Section 4: Normal Procedures, "Preflight Inspection"](#) for more information.

Methodology

Aircraft emergencies are dynamic events. Because of this, it is impossible to enumerate every action a pilot should properly undertake in response to a particular situation. However, four basic actions can be applied to any emergency. They are:

Maintain Aircraft Control

Many minor aircraft emergencies turn into major ones when the pilot fails to maintain aircraft control. Do not panic and do not fixate on a particular problem. Over-attention to a warning light during an instrument approach can lead to a pilot-induced unusual attitude, and possibly worse. To avoid this, even in an emergency: always aviate, navigate, and communicate, in that order. Never let anything interfere with your control of the airplane. Never stop flying.

Analyze the Situation

Once you are able to maintain control of the aircraft, assess the situation. Read all warning and caution messages. Evaluate the engine parameters. Consider all aircraft operational information at your disposal.

Take Appropriate Action

In many situations, the procedures listed in this section will either correct or mitigate the aircraft problem or allow safe recovery of the aircraft. Follow them and use good pilot judgment.

• NOTE •

In an in-flight emergency, pressing and holding the COM transfer button for 2 seconds will tune the emergency frequency of 121.500 MHz. If the display is available, it will also show it in the “Active” frequency window.

The Cirrus Airframe Parachute System (CAPS) should be activated in the event of a life-threatening emergency where CAPS deployment is determined to be safer than continued flight and landing.

• NOTE •

Refer to Section 10, [Cirrus Airframe Parachute System \(CAPS\)](#) for CAPS deployment information and landing considerations.

Land as Soon as Conditions Permit

Once you have evaluated and responded to the emergency, assess your next move. Perform any non-critical “clean-up” items in the checklist and land as soon as practicable. Even if the airplane appears to be in sound condition, it may not be.

• NOTE •

Refer to [Landing Guidance](#) in this section for factors that determine landing criticality.

Circuit Breakers

Some procedures involve manipulating circuit breakers (CBs). The following criteria should be followed during “Circuit Breaker” steps:

- Intentional pulling of circuit breakers during flight, other than as required in specific procedures, may cause abnormal or unexpected system behavior and is not recommended.
- When instructed to “SET”, the appropriate circuit breaker should be checked for normal condition. If the circuit breaker is not “SET”, it may be reset only once. If the circuit breaker opens again, do not reset.
- When instructed to “PULL”, the appropriate circuit breaker should only be pulled and not reset.
- When instructed to “CYCLE”, the appropriate circuit breaker should be pulled, delayed for several seconds, and reset only once. Allow sufficient cooling time for circuit breakers that are reset through a “CYCLE” procedure.

Memory Items

Checklist steps emphasized by a rectangular enclosure, such as the example below, should be memorized for accomplishment without reference to the procedure, due to the nature of their urgency.

1. Best Glide Speed ESTABLISH

If the rectangle is open at the top or bottom of the page, additional steps related to the memory item(s) precede or follow those listed on the current page.

Procedure Division Symbols

For procedures requiring pilot decision, conditional steps are indented with a symbol to designate sub-sections within the procedure. On condition, the pilot makes a decision to identify the applicable sub-section.

Following the initial decision, a further sub-division of the procedure may occur. In that event, one or more additional conditions guides the pilot through the remaining decisions. Once the applicable condition(s) are identified, the pilot follows the remaining steps until the indication "Procedure Complete" is reached.

The procedure symbol levels are:

- ◆ First Level
- Second Level
- Third Level

Landing Guidance

Land as Soon as Practicable

Extended flight is not recommended and the pilot should proceed to land the plane, but not necessarily at the first or closest landing location. The landing location and duration of flight remains at the discretion of the pilot in command, after considering all factors related to the safety of the flight. For example, landing may be deferred to an airfield which could provide post-landing maintenance procedures or malfunction investigation. The choice of airfield may be determined by the pilot with consideration to weather, runway dimensions, surface conditions, and services available. However, in no case shall a suitable landing airfield be discounted in the name of convenience.

Land as Soon as Possible

Land without delay at the first site at which a safe landing can be made. Continued flight beyond an available airfield at which a safe landing can be made will result in increased risk and shall not be attempted. The nearest suitable landing site shall be determined by the pilot with consideration given to weather, surface dimensions and conditions, and pilot experience.

Airspeeds for Emergency Operations

Maneuvering Speed

3150 lb (1429 kg).....	133 KIAS
2700 lb (1225 kg).....	123 KIAS
2300 lb (1043 kg).....	114 KIAS

Best Glide (Flaps: UP)

3150 lb (1429 kg).....	100 KIAS
2600 lb (1179 kg).....	92 KIAS

Emergency Landing

Flaps UP	89 KIAS
Flaps 50%	83 KIAS
Flaps 100%	78 KIAS

Engine Failures

Engine Failure On Takeoff - Low Altitude

1. Best Glide or Landing SpeedESTABLISH
2. Mixture CUTOFF
3. Fuel Selector..... OFF
4. Ignition Switch OFF
5. Flaps AS REQUIRED

◆ If time permits:

- a. Power Lever IDLE
- b. Fuel Pump..... OFF
- c. Seat Belts ENSURE SECURED
- d. BAT 1, BAT 2, ALT 1, and ALT 2 Switches..... OFF

Procedure Complete

• WARNING •

If engine failure is accompanied by fuel fumes in the cockpit, or if internal engine damage is suspected, move Mixture Control to CUTOFF, Fuel Selector to OFF, and do not attempt a restart.

If a turn back to the runway is elected, be very careful not to stall the airplane.

• NOTE •

If the engine fails immediately after becoming airborne, abort on the runway if possible. If altitude precludes a runway stop but is not sufficient to restart the engine, lower the nose to maintain airspeed and establish a glide attitude. In most cases, the landing should be made straight ahead, turning only to avoid obstructions.

After establishing a glide for landing, perform as many of the checklist items as time permits.

Turning off BAT 1, BAT 2, ALT 1, and ALT 2 switches will result in loss of PFD, and should be delayed until immediately before impact.

Engine Failure In Flight

1. Best Glide Speed ESTABLISH
2. Mixture AS REQUIRED
3. Fuel Pump ON
4. Fuel Selector SWITCH TANKS
5. Alternate Induction Air ON
6. Ignition Switch CHECK LEFT, RIGHT, BOTH (AS REQ'D)

◆ If engine does not start:

- a. Perform **Engine Airstart**, **CAPS Deployment**, or **Emergency Landing w/o Power** Checklist, as required.

Procedure Complete

◆ If engine starts:

- a. CHTs and Oil Temperature WARM ENGINE AT PARTIAL POWER IF REQUIRED

Procedure Complete

• **WARNING** •

If engine failure is accompanied by fuel fumes in the cockpit, or if internal engine damage is suspected, move Mixture Control to CUTOFF, Fuel Selector to OFF, and do not attempt a restart.

If a turn back to the runway is elected, be very careful not to stall the airplane.

• **NOTE** •

If the engine fails at altitude, pitch as necessary to establish best glide speed. While gliding toward a suitable landing area, attempt to identify the cause of the failure and correct it. If altitude or terrain does not permit a safe landing, CAPS deployment may be required. Refer to Section 10, **Cirrus Airframe Parachute System (CAPS)** for CAPS deployment scenarios and landing considerations.

If the engine fails to produce power when the power lever is advanced, it is possible the mixture is set overly rich and/or the power lever was advanced too rapidly resulting in an overly rich fuel air mixture in the engine. Reduce the power lever to idle or until the engine begins to accelerate and advance slowly (3 seconds or greater from idle to full power). Lean mixture as required.

Airstart

Engine Airstart

1. BAT 1 and BAT 2 Switches ON
2. Power Lever OPEN ½ INCH
3. Mixture RICH, AS REQ'D
4. Fuel Pump ON
5. Fuel Selector SWITCH TANKS
6. Ignition Switch BOTH
7. Alternate Induction Air ON
8. ALT 1 and ALT 2 Switches OFF
9. Starter (Propeller not Windmilling) ENGAGE
10. Power Lever SLOWLY INCREASE
11. ALT 1 and ALT 2 Switches ON
12. CHTs and Oil Temperature .. WARM ENGINE AT PARTIAL POWER IF REQUIRED
13. If engine will not start, perform [Emergency Landing w/o Power](#) Checklist.

Procedure Complete

• NOTE •

Switching tanks and turning the fuel pump on will enhance starting if fuel contamination was the cause of the failure. Leaning the mixture and then slowly enriching mixture may correct faulty mixture control.

Engine airstarts may be performed during 1g flight anywhere within the normal operating envelope of the airplane.

Smoke and Fire

Cabin Fire In Flight

- | | |
|--|------------------|
| 1. BAT 1, ALT 1, and ALT 2 Switches..... | OFF, AS REQUIRED |
| 2. Fire Extinguisher | ACTIVATE |
3. AVIONICS SwitchOFF
 4. All other switchesOFF
 5. Land as soon as possible.

◆ If setting master switches off eliminated source of fire or fumes and airplane is in night, weather, or IFR conditions:

- a. Airflow SelectorOFF
- b. BAT 1, BAT 2, ALT 1, and ALT 2 Switches ON
- c. AVIONICS Switch..... ON
- d. Required SystemsACTIVATE ONE AT A TIME
- e. Temperature SelectorCOLD
- f. Vent Selector..... FEET/PANEL/DEFROST POSITION
- g. Airflow Selector..... SET AIRFLOW TO MAXIMUM
- h. Panel Eyeball Outlets..... OPEN
- i. Land as soon as possible.

Procedure Complete

• NOTE •

With master switches OFF, engine will continue to run. However, no electrical power will be available.

(Continued on next page)

(Continued)

• NOTE •

If the airplane is in IMC conditions, turn ALT 1, ALT 2, and BAT 1 switches OFF. Power from battery 2 will keep the Primary Flight Display operational for approximately 30 minutes. If airplane is in day VFR conditions and turning off the master switches eliminated the fire situation, leave the master switches OFF. Do not attempt to isolate the source of the fire by checking each individual electrical component.

If the cause of the fire is readily apparent and accessible, use the fire extinguisher to extinguish flames and land as soon as possible. Opening the vents or doors may feed the fire, but to avoid incapacitating the crew from smoke inhalation, it may be necessary to rid cabin of smoke or fire extinguishant.

If required to re-activate systems, pause several seconds between activating each system to isolate malfunctioning system. Continue flight to earliest possible landing with malfunctioning system off.

Activate only the minimum amount of equipment necessary to complete a safe landing.

Engine Fire In Flight

- | | |
|------------------------------|--------|
| 1. Mixture | CUTOFF |
| 2. Fuel Pump | OFF |
| 3. Fuel Selector | OFF |
| 4. Airflow Selector | OFF |
| 5. Power Lever | IDLE |
| 6. Ignition Switch | OFF |
| 7. Land as soon as possible. | |

Procedure Complete

• NOTE •

If an engine fire occurs during flight, do not attempt to restart the engine.

Wing Fire In Flight

1. Pitot Heat Switch.....OFF
2. Navigation Light SwitchOFF
3. Landing Light.....OFF
4. Strobe Light SwitchOFF
5. If possible, side slip to keep flames away from fuel tank and cabin.
6. Land as soon as possible.

Procedure Complete

• CAUTION •

Putting the airplane into a dive may blow out the fire. Do not exceed V_{NE} during the dive.

Engine Fire During Start

1. MixtureCUTOFF
2. Fuel PumpOFF
3. Fuel SelectorOFF
4. Power Lever.....FORWARD
5. StarterCRANK
6. If flames persist, perform [Emergency Engine Shutdown On Ground](#) and [Emergency Ground Egress](#) Checklists.

Procedure Complete

• NOTE •

A fire during engine start may be caused by fuel igniting in the fuel induction system. If this occurs, attempt to draw the fire back into the engine by continuing to crank the engine.

Smoke and Fume Elimination

1. Air Conditioner (if installed) OFF
2. Temperature Selector COLD
3. Vent Selector..... FEET/PANEL/DEFROST POSITION
4. Airflow Selector.....SET AIRFLOW TO MAXIMUM

◆ If source of smoke and fume is firewall forward:

- a. Airflow Selector OFF
5. Panel Eyeball Outlets..... OPEN
 6. Prepare to land as soon as possible.

Procedure Complete

• NOTE •

If smoke and/or fumes are detected in the cabin, check the engine parameters for any sign of malfunction. If a fuel leak has occurred, actuation of electrical components may cause a fire. If there is a strong smell of fuel in the cockpit, divert to the nearest suitable landing field. Perform [Forced Landings](#) Checklist and shut down the fuel supply to the engine once a safe landing is assured.

Emergency Descent

- | |
|---|
| <ol style="list-style-type: none">1. Power Lever IDLE2. Mixture..... AS REQUIRED3. Airspeed V_{NE} |
|---|

Procedure Complete

• CAUTION •

If significant turbulence is expected, do not descend at indicated airspeeds greater than V_{NO} (164 KIAS).

Glide

Conditions		Example	
Power	OFF	Altitude	8,000 ft. AGL
Propeller	Windmilling	Airspeed	Best Glide
Flaps	0% (UP)	Glide Distance	12 NM
Wind	Zero		

Best Glide Speed

3150 lb (1429 kg)..... 100 KIAS
 2600 lb (1179 kg)..... 92 KIAS

Figure 3-1: Maximum Glide Ratio ~ 9 : 1

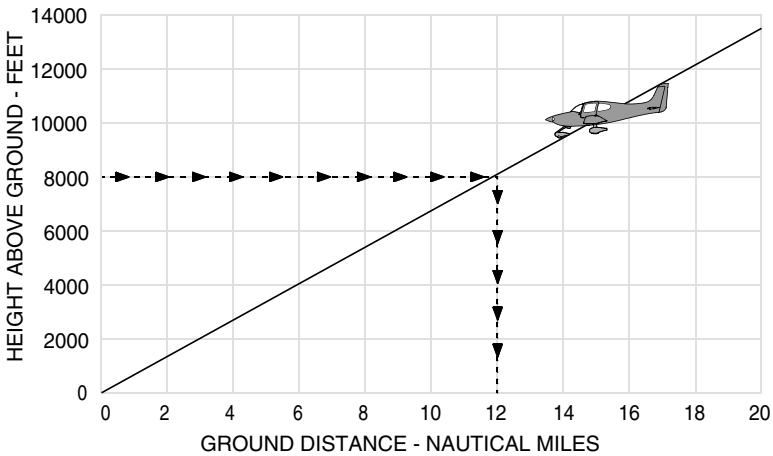

SR20_FM09_2765

Forced Landings

Emergency Landing w/o Power

- | | |
|--------------------------|--|
| 1. Best Glide Speed..... | ESTABLISH |
| 2. Radio..... | TRANSMIT (121.5 MHz) MAYDAY GIVING LOCATION AND INTENTIONS |
| 3. Transponder | SQUAWK 7700 |
| 4. Power Lever | IDLE |
| 5. Mixture..... | CUTOFF |
| 6. Fuel Selector..... | OFF |
| 7. Ignition Switch | OFF |
| 8. Fuel Pump..... | OFF |
9. Flaps (when landing is assured) 100%
10. Seat Belt(s) SECURED
11. BAT 1, BAT 2, ALT 1, and ALT 2 Switches OFF

Procedure Complete

• NOTE •

If all attempts to restart the engine fail and a forced landing is imminent, select a suitable field and prepare for the landing. If flight conditions or terrain does not permit a safe landing, CAPS deployment may be required. Refer to Section 10, [Cirrus Airframe Parachute System \(CAPS\)](#) for CAPS deployment scenarios and landing considerations.

A suitable field should be chosen as early as possible so that maximum time will be available to plan and execute the forced landing. For forced landings on unprepared surfaces, use full flaps if possible. Be aware that use of full (100%) flaps will reduce glide distance. Full flaps should not be selected until landing is assured. Land on the main gear and hold the nose wheel off the ground as long as possible.

Ditching

1. Radio TRANSMIT (121.5 MHz) MAYDAY GIVING LOCATION AND INTENTIONS
2. Transponder..... SQUAWK 7700
3. CAPS ACTIVATE
4. AirplaneEVACUATE
5. Flotation Devices.....INFLATE WHEN CLEAR OF AIRPLANE

Procedure Complete

• NOTE •

If available, life preservers should be donned and life raft should be prepared for immediate evacuation upon touchdown.

Consider unlatching a door prior to assuming the emergency landing body position in order to provide a ready escape path.

It may be necessary to allow some cabin flooding to equalize pressure on the doors. If the doors cannot be opened, break out the windows with the egress hammer and crawl through the opening.

Landing Without Elevator Control

1. Flaps 50%
2. Trim 80 KIAS
3. Power AS REQUIRED FOR GLIDE ANGLE

Procedure Complete

• NOTE •

The pitch trim spring cartridge is attached directly to the elevator and provides a backup should you lose the primary elevator control system. Set elevator trim for a 80 KIAS approach to landing. Thereafter, do not change the trim setting until in the landing flare. During the flare, the nose-down moment resulting from a power reduction may cause the airplane to hit on the nose-wheel. At touchdown, bring the power lever to idle.

Engine System Emergencies

Engine Partial Power Loss

1. Air Conditioner (if installed) OFF
2. Fuel Pump ON
3. Fuel Selector SWITCH TANKS
4. Mixture CHECK APPROPRIATE FOR FLIGHT CONDITIONS
5. Power Lever SWEEP
6. Alternate Induction Air ON
7. Ignition Switch BOTH, L, THEN R
8. Land as soon as practicable.

Procedure Complete

• WARNING •

If there is a strong smell of fuel in the cockpit, divert to the nearest suitable landing field. Fly a forced landing pattern and shut down the engine fuel supply once a safe landing is assured.

• NOTE •

Indications of a partial power loss include fluctuating RPM, reduced or fluctuating manifold pressure, low oil pressure, high oil temperature, and a rough-sounding or rough-running engine. Mild engine roughness in flight may be caused by one or more spark plugs becoming fouled. A sudden engine roughness or misfiring is usually evidence of a magneto malfunction.

A gradual loss of manifold pressure and eventual engine roughness may result from the formation of intake ice. Opening the alternate engine air will provide air for engine operation if the normal source is blocked or the air filter is iced over.

(Continued on next page)

(Continued)

• NOTE •

Low oil pressure may be indicative of an imminent engine failure.

See [OIL PRESS Warning Checklist](#) in this Section for special procedures with low oil pressure.

A damaged (out-of-balance) propeller may cause extremely rough operation. If an out-of-balance propeller is suspected, immediately shut down engine and perform [Forced Landings Checklist](#).

If the power loss is due to a fuel leak in the injector system, fuel sprayed over the engine may be cooled by the slipstream airflow which may prevent a fire at altitude. However, as the Power Lever is reduced during descent and approach to landing the cooling air may not be sufficient to prevent an engine fire.

Selecting fuel pump ON on may clear the problem if vapor in the injection lines is the problem or if the engine-driven fuel pump has partially failed. The electric fuel pump will not provide sufficient fuel pressure to supply the engine if the engine-driven fuel pump completely fails.

Selecting the opposite fuel tank may resolve the problem if fuel starvation or contamination in one tank was the problem.

Cycling the ignition switch momentarily from BOTH to L and then to R may help identify the problem. An obvious power loss in single ignition operation indicates magneto or spark plug trouble. Lean the mixture to the recommended cruise setting. If engine does not smooth out in several minutes, try a richer mixture setting. Return ignition switch to the BOTH position unless extreme roughness dictates the use of a single magneto.

If a partial engine failure permits level flight, land at a suitable airfield as soon as conditions permit. If conditions do not permit safe level flight, use partial power as necessary to set up a forced landing pattern over a suitable landing field. Always be prepared for a complete engine failure and consider CAPS deployment if a suitable landing site is not available. Refer to Section 10, [Cirrus Airframe Parachute System \(CAPS\)](#) for CAPS deployment scenarios and landing considerations.

OIL PRESS Warning

OIL PRESS

Oil Pressure Out of Range

1. Oil Pressure Gauge CHECK

◆ If pressure low / high:

a. Power..... REDUCE TO MINIMUM FOR SUSTAINED FLIGHT

b. Land as soon as possible.

(1) Prepare for potential engine failure.

Procedure Complete

• NOTE •

It is possible for sensors to produce erroneous warnings. Carefully evaluate other engine parameters and smoothness of operation before taking action.

If oil pressure is low, the engine has probably lost a significant amount of its oil and engine failure may be imminent.

If oil pressure is suddenly high, a blockage or obstruction may have developed in the oil circulation system and engine failure may be imminent.

OIL TEMP Warning

OIL TEMP

Oil Temperature High

1. PowerREDUCE

2. Airspeed INCREASE

3. Mixture AS REQUIRED

4. Oil Temperature Gauge MONITOR

◆ If message persists:

a. Land as soon as possible.

Procedure Complete

CHT Caution and Warning

CHT

High Cylinder Head Temperature

◆ If on ground:

- a. Power Lever REDUCE
- b. Annunciations and Engine Temperatures MONITOR

○ If Caution or Warning annunciation is still illuminated:

- (1) Power Lever MINIMUM REQUIRED
- (2) Flight PROHIBITED

Procedure Complete

◆ If in flight:

- a. Power Lever REDUCE
- b. Airspeed INCREASE
- c. Mixture ADJUST FUEL FLOW TO TOP OF GREEN ARC
- d. Annunciations and Engine Temperatures MONITOR

○ If Caution or Warning annunciation is still illuminated:

- (1) Power Lever MINIMUM REQUIRED
- (2) Engine Instruments MONITOR

☐ If Caution annunciation only remains illuminated:

- (a) Land as soon as practicable.

☐ If Warning annunciation remains illuminated:

- (a) Land as soon as possible.

Procedure Complete

Propeller System Emergencies

RPM Warning

RPM

Engine Speed High

1. Tachometer..... CHECK

◆ If engine speed normal:

- a. If on ground..... CORRECT PRIOR TO FLIGHT
- b. If in flightCONTINUE, MONITOR

Procedure Complete

◆ If engine speed high:

- a. Perform [Propeller Governor Failure](#) Checklist.

2. Oil Pressure Gauge CHECK

Procedure Complete

Propeller Governor Failure

Propeller RPM Will Not Increase

1. Oil Pressure..... CHECK
2. Land as soon as practicable.

Procedure Complete

Propeller Overspeeds or Will Not Decrease

1. Power LeverADJUST (TO KEEP RPM IN LIMITS)
2. Airspeed REDUCE TO 90 KIAS
3. Land as soon as practicable.

Procedure Complete

• NOTE •

If the RPM does not respond to power lever movement or over-speeds, the most likely cause is a faulty governor or an oil system malfunction. If moving the power lever is difficult or rough, suspect a power lever linkage failure and perform the [Power Lever Linkage Failure](#) Checklist.

Fuel System Emergencies

FUEL LOW LEFT Warning

FUEL LOW LEFT

Low Fuel Quantity in Left Tank

1. Fuel Quantity Gauges CHECK
2. Fuel Pump ON
3. Fuel Selector RIGHT TANK

Procedure Complete

• NOTE •

Left fuel tank sensed quantity less than 1 gallon.

FUEL LOW RIGHT Warning

FUEL LOW RIGHT

Low Fuel Quantity in Right Tank

1. Fuel Quantity Gauges CHECK
2. Fuel Pump ON
3. Fuel Selector LEFT TANK

Procedure Complete

• NOTE •

Right fuel tank sensed quantity is less than 1 gallon.

FUEL LOW TOTAL Warning

FUEL LOW TOTAL

Low Fuel Quantity

1. Fuel Quantity Gauges CHECK
2. Totalized Fuel Quantity CHECK

◆ If totalized fuel quantity differs significantly from sensed quantity:

- a. Initial Fuel Value VERIFY AND CORRECT

◆ If message persists:

- a. Land as soon as practicable.

Procedure Complete

• NOTE •

Fuel Totalizer or sensed quantity is less than 7 gallons.

FUEL IMBALANCE Warning

FUEL IMBALANCE

Fuel Imbalance

1. Fuel Quantity Gauges CHECK
2. Fuel Pump ON
 - a. If the Boost Pump is already in use for vapor suppression, pump should be left in this position for tank switch.
3. Fuel Selector SELECT FULLER TANK
4. Fuel Pump AS REQUIRED
 - a. After switching tanks, message will remain until sensed imbalance is less than 9.5 gallons.

Procedure Complete

• NOTE •

Fuel level imbalance (between left and right) is greater than 9.5 gallons.

Electrical System Emergencies

M BUS 1 Warning

M BUS 1

High Voltage on Main Bus 1

1. ALT 1 Switch..... CYCLE
2. M Bus 1 Voltage (M1) CHECK

◆ If M Bus 1 Voltage is greater than 32 volts:

- a. ALT 1 SwitchOFF
- b. Perform [ALT 1 Caution \(Failure\)](#) Checklist (do not reset alternator).

Procedure Complete

• NOTE •

Main Bus 1 Voltage is excessive, indicates an alternator 1 voltage regulator failure; will typically be associated with abnormally high voltage indications on M1, M2 and ESS buses, may also be associated with [M BUS 2 Warning](#) or [ESS BUS Warning](#) message.

M BUS 2 Warning

M BUS 2

High Voltage on Main Bus 2

1. Main Bus 1 Voltage (M1)..... CHECK

◆ If M Bus 1 Voltage is greater than 32 volts:

a. Perform **M BUS 1 Warning** Checklist.

2. Main Bus 2 Voltage (M2)..... CHECK

◆ If M Bus 2 Voltage is greater than 32 volts:

a. ALT 2 Switch..... CYCLE

b. Main Bus 2 Voltage (M2) CHECK

○ If M Bus 2 Voltage remains greater than 32 volts:

(1) ALT 2 Switch OFF

(2) Perform **ALT 2 Caution (Failure)** Checklist (do not reset alternator).

Procedure Complete

• **NOTE** •

Main Bus 2 Voltage is excessive. Indicates an alternator voltage regulator failure; will typically be associated with abnormally high bus voltage indications on M2 and ESS, may also be associated with **M BUS 1 Warning** and **ESS BUS Warning** Messages.

ESS BUS Warning

ESS BUS

High or Low Voltage on Essential Bus

1. Essential Bus Voltage (ESS) CHECK

◆ If Essential Bus Voltage is greater than 32 Volts:

- a. Main Bus 1 and Main Bus 2 Voltages (M1 and M2)..... CHECK
- b. Perform appropriate [M BUS 1 Warning](#) or [M BUS 2 Warning](#) Checklist.

◆ If Essential Bus Voltage is less than 24.5 Volts:

- a. Perform [ALT 1 Caution \(Failure\)](#) and [ALT 2 Caution \(Failure\)](#) Checklists.

◆ If unable to restore at least one alternator:

- a. Non-Essential Loads REDUCE

○ If flight conditions permit, consider shedding:

- (1) Air Conditioning
- (2) Landing Light
- (3) Pitot Heat
- (4) Cabin Fan
- (5) Nav Lights
- (6) Strobe Lights
- (7) Audio Panel
- (8) COM 2

2. Land as soon as practicable (Battery reserve only).

Procedure Complete

• CAUTION •

Dependent on battery state, flaps and landing light may be unavailable on landing.

• NOTE •

Essential Bus voltage is high or low. High voltage indicates alternator voltage regulator failure; will typically be associated with high M1 and/or M2 voltages and [M BUS 1 Warning](#) and/or [M BUS 2 Warning](#) messages.

Low voltage indicates dual failures of Alternators 1 and 2, will typically be associated with low M1 and M2 voltages, [M BUS 1 Caution](#) and [M BUS 2 Caution](#) messages, and [ALT 1 Caution \(Failure\)](#) and [ALT 2 Caution \(Failure\)](#) messages.

Environmental System Emergencies

CO LVL HIGH Warning

CO LVL HIGH

Carbon Monoxide Level High

1. Air Conditioner (if installed)NOT IN RECIRC MODE
2. Temperature Selector COLD
3. Vent Selector..... FEET/PANEL/DEFROST POSITION
4. Airflow SelectorSET AIRFLOW TO MAXIMUM
5. Panel Eyeball Outlets..... OPEN

◆ If CO LVL HIGH does not extinguish:

- a. Supplemental Oxygen (if available)
 - (1) Oxygen Masks or Cannulas DON
 - (2) Oxygen System ON
 - (3) Oxygen Flow RateMAXIMUM
- b. Land as soon as possible.

Procedure Complete

• NOTE •

Annunciation indicates carbon monoxide level is greater than 50 PPM. Ensure that air condition is not in recirculate mode and that air temperature is set to full COLD to supply maximum amount of fresh air to cabin.

Integrated Avionics System Emergencies

A “Red X” through any electronic display field, such as COM frequencies, NAV frequencies, or engine data, indicates that display field is not receiving valid data.

Attitude & Heading Reference System (AHRS) Failure

1. Verify Avionics System has switched to functioning AHRS.
If not, manually switch to functioning AHRS and attempt to bring failed AHRS back on-line:
2. Failed ADAHRS Circuit Breaker..... SET
If open, reset (close) circuit breaker. If circuit breaker opens again, do not reset.
3. Be prepared to revert to Standby Instruments (Attitude, Heading).

Procedure Complete

• NOTE •

Failure of the Attitude and Heading Reference System (AHRS) is indicated by removal of the sky/ground presentation and a “Red X” and a yellow “ATTITUDE FAIL” shown on the PFD. The digital heading presentation will be replaced with a yellow “HDG” and the compass rose digits will be removed. The course pointer will indicate straight up and course may be set using the digital window.

Air Data Computer (ADC) Failure

1. Failed ADAHRS Circuit Breaker..... SET
If open, reset (close) circuit breaker. If circuit breaker opens again, do not reset.
2. Revert to Standby Instruments (Altitude, Airspeed).
3. Land as soon as practicable.

Procedure Complete

• NOTE •

Complete loss of the Air Data Computer is indicated by a “Red X” and yellow text over the airspeed, altimeter, vertical speed, TAS and OAT displays. Some FMS functions, such as true airspeed and wind calculations, will also be lost.

PFD Display Failure

1. Display Backup..... ACTIVATE
2. Land as soon as practicable.

Procedure Complete

Unusual Attitude Emergencies

Inadvertent Spin Entry

- | |
|-----------------------|
| 1. CAPS..... ACTIVATE |
|-----------------------|

Procedure Complete

• **WARNING** •

In all cases, if the aircraft enters an unusual attitude following or in connection with a stall, a spin condition should be assumed and, immediate deployment of the CAPS is required. Under no circumstances should spin recovery other than CAPS deployment be attempted.

• **NOTE** •

The aircraft is not approved for spins, and has not been certified for traditional spin recovery characteristics. The only approved and demonstrated method of spin recovery is activation of the Cirrus Airframe Parachute System (see [CAPS Deployment Checklist](#), this section). Because of this, if the aircraft enters a spin, CAPS must be deployed immediately.

While the stall characteristics of the aircraft make inadvertent entry into a spin extremely unlikely, it is possible. Spin entry can be avoided by using good airmanship: coordinated use of controls in turns, proper airspeed control following the recommendations of this Handbook, and never abusing the flight controls with uncoordinated or abrupt inputs when close to the stall (see Section 4, [Stalls](#) discussion).

If, at the stall, the controls are misapplied and abused aggressive inputs are made to the elevator, rudder and/or ailerons, an abrupt wing drop may be felt and a spin may be entered.

SPIN SPIN SPIN Warning

SPIN SPIN SPIN

Spin Entry Detected – Initiate Recovery

1. CAPS ACTIVATE

Procedure Complete

• WARNING •

In all cases, if the aircraft enters an unusual attitude following or in connection with a stall, a spin condition should be assumed and, immediate deployment of the CAPS is required. Under no circumstances should spin recovery other than CAPS deployment be attempted.

• NOTE •

The aircraft is not approved for spins, and has not been certified for traditional spin recovery characteristics. The only approved and demonstrated method of spin recovery is activation of the Cirrus Airframe Parachute System (see [CAPS Deployment Checklist](#), this section). Because of this, if the aircraft enters a spin, CAPS must be deployed immediately.

While the stall characteristics of the aircraft make inadvertent entry into a spin extremely unlikely, it is possible. Spin entry can be avoided by using good airmanship: coordinated use of controls in turns, proper airspeed control following the recommendations of this Handbook, and never abusing the flight controls with uncoordinated or abrupt inputs when close to the stall (see Section 4, [Stalls](#) discussion).

If, at the stall, the controls are misapplied and abused aggressive inputs are made to the elevator, rudder and/or ailerons, an abrupt wing drop may be felt and a spin may be entered.

Inadvertent Spiral Dive During IMC Flight

1. Power Lever IDLE
 2. Stop the spiral dive by using coordinated aileron and rudder control while referring to the attitude indicator and turn coordinator to level the wings.
 3. Cautiously apply elevator back pressure to bring airplane to level flight attitude.
4. Trim for level flight.
 5. Set power as required.
 6. Use autopilot if functional otherwise maintain a constant heading through the coordinated aileron and rudder inputs.
 7. Exit IMC conditions as soon as possible.

Procedure Complete

• NOTE •

In all cases, if the aircraft enters an unusual attitude from which recovery is not assured, immediately deploy CAPS. Refer to Section 10, [Cirrus Airframe Parachute System \(CAPS\)](#) for CAPS deployment information.

Other Emergencies

Power Lever Linkage Failure

1. Power Lever MovementVERIFY
2. Power..... SET IF ABLE
3. Flaps SET IF NEEDED
4. Mixture AS REQUIRED (FULL RICH TO CUTOFF)
5. Land as soon as possible.

Procedure Complete

• NOTE •

If the Power Lever linkage fails in flight, the engine will not respond to power lever control movements. Use power available and flaps as required to safely land the airplane.

If the power lever is stuck at or near the full power position, proceed to a suitable airfield. Fly a forced landing pattern. With landing assured, shut down engine by moving mixture control full aft to CUTOFF. If power is needed again, return mixture control to full RICH and regain safe pattern parameters or go-around. If airspeed cannot be controlled, shut engine down and perform the [Forced Landings](#) Checklist. After landing, bring the airplane to a stop and complete the [Emergency Engine Shutdown On Ground](#) Checklist.

If the power lever is stuck at or near the idle position and straight and level flight cannot be maintained, establish glide to a suitable landing surface. Fly a forced landing pattern.

Emergency Engine Shutdown On Ground

- | | |
|-----------------------------|--------|
| 1. Power Lever..... | IDLE |
| 2. Fuel Pump (if used)..... | OFF |
| 3. Mixture..... | CUTOFF |
| 4. Fuel Selector..... | OFF |
| 5. Ignition Switch..... | OFF |
6. BAT 1, BAT 2, ALT 1, and ALT 2 SwitchesOFF

Procedure Complete

BRAKE TEMP Warning

BRAKE TEMP

Left/Right Brake Over-Temperature Annunciation

1. Stop aircraft and allow the brakes to cool.
Procedure Complete

• WARNING •

Do not set parking brake unless required for safety.

• NOTE •

Annunciation indicates brake temperature is greater than 293 °F.
Refer to Section 10, [Taxiing, Steering, and Braking Practices](#) for additional information.

START ENGAGED Warning

START ENGAGED

Starter Engaged Annunciation

◆ If on ground:

- a. Ignition Switch.....DISENGAGE
- b. Wait 1 minute before next start attempt.

○ If starter does not disengage (relay or solenoid failure):

- (1)BAT 1 Switch OFF
- (2)Engine SHUTDOWN
- (3)STARTER Circuit Breaker..... PULL

Procedure Complete

◆ If in flight:

- a. Ignition Switch..... ENSURE NOT STUCK IN START
- b. STARTER Circuit Breaker PULL

(Continued on next page)

(Continued)

c. Flight.....CONTINUE

(1) Engine start will not be available at destination.

Procedure Complete

• WARNING •

Use caution after shutdown if STARTER circuit breaker required pull (failed relay or solenoid). If breaker is unknowingly or unintentionally reset, starter will instantly engage if Battery 1 power is supplied; creating a hazard for ground personnel.

• NOTE •

Starter has been engaged for more than 30 seconds (starter limit is 10 seconds); if not manually engaged, such as during difficult start, this annunciation may indicate a failure of the starter solenoid or a stuck keyswitch.

Emergency Ground Egress

- | | |
|---------------------|----------|
| 1. Engine..... | SHUTDOWN |
| 2. Seat Belts | RELEASE |
| 3. Airplane..... | EXIT |

Procedure Complete

• WARNING •

While exiting the airplane, make sure evacuation path is clear of other aircraft, spinning propellers, and other hazards.

If the engine is left running, set the Parking Brake prior to evacuating the airplane.

If the doors cannot be opened, break out the windows with egress hammer, located in the console between the front seats, and crawl through the opening.

CAPS Deployment

• WARNING •

The maximum demonstrated deployment speed is 133 KIAS.

- | | |
|---|--------------------|
| 1. Activation Handle Cover | REMOVE |
| 2. Activation Handle (Both Hands) | PULL STRAIGHT DOWN |

After deployment, as time permits:

- | | |
|--|--------|
| 3. Mixture | CUTOFF |
| 4. Fuel Selector | OFF |
| 5. Fuel Pump | OFF |
| 6. BAT 1, BAT 2, ALT 1, and ALT 2 Switches | OFF |
- Turn the master switches off after completing any necessary radio communications.
- | | |
|-----------------------------------|---------|
| 7. Ignition Switch | OFF |
| 8. ELT | ON |
| 9. Seat Belts and Harnesses | TIGHTEN |
| 10. Loose Items | SECURE |
11. Assume emergency landing body position.
12. After the airplane comes to a complete stop, evacuate quickly and move upwind.

Procedure Complete

• WARNING •

Jerking or rapidly pulling the activation T-handle will greatly increase the pull forces required to activate the rocket. Use a firm and steady pulling motion – a “chin-up” type pull ensures successful activation.

• NOTE •

The Cirrus Airframe Parachute System (CAPS) should be activated immediately in the event of a spin. It should also be used in other life threatening emergencies where CAPS deployment is determined to be safer than continued flight and landing.

Expected impact in a fully stabilized deployment is equivalent to a drop from approximately 10 feet.

(Continued on next page)

(Continued)

• CAUTION •

CAPS deployment will likely result in damage or loss to the airframe.

• NOTE •

Several possible scenarios in which the activation of the CAPS would be appropriate are discussed in [Section 10: Safety Information](#) of this Handbook. These include:

- Mid-air collision
- Structural failure
- Loss of control
- Landing in inhospitable terrain
- Pilot incapacitation

All pilots should carefully review the information on CAPS activation and deployment in Section 10 before operating the airplane.

Intentionally Left Blank

Section 3A: Abnormal Procedures

Table of Contents

Introduction.....	3
Crew Alert System (CAS) Messaging	3
Cautions	3
Advisories	3
Abnormal Procedures Guidance	3
Circuit Breakers	4
Procedure Division Symbols	4
Landing Guidance	5
Land as Soon as Practicable.....	5
Land as Soon as Possible	5
Flight Environment	5
Inadvertent Icing Encounter	5
Inadvertent IMC Encounter	6
Door Open In Flight.....	6
Abnormal Landings	7
Landing With Failed Brakes	7
Landing With Flat Tire	7
Engine System	8
OIL PRESS Caution	8
OIL TEMP Caution	8
START ENGAGED Caution	9
Fuel System	10
FUEL LOW TOTAL Caution	10
FUEL IMBALANCE Caution	10
FUEL IMBALANCE Advisory.....	11
Electrical System.....	11
M BUS 1 Caution.....	11
M BUS 2 Caution.....	12
BATT 1 Caution	12
ALT 1 Caution (Failure)	13
ALT 2 Caution (Failure)	14
Integrated Avionics System.....	14
AVIONICS OFF Caution.....	14
PFD FAN FAIL Advisory	15
MFD FAN FAIL Advisory	15
Flight Displays Too Dim	16

Pitot Static System	17
Static Source Blocked	17
Pitot Tube Blocked	17
PITOT HEAT FAIL Caution	18
PITOT HEAT REQD Caution.....	18
Flight Control System	19
Electric Trim/Autopilot Failure.....	19
FLAPS OVERSPEED Caution	19
TAKEOFF FLAPS Caution	20
FLAPS CLIMB Advisory	20
Landing Gear System.....	21
Brake Failure During Taxi.....	21
BRAKE TEMP Caution.....	21
Other Conditions.....	22
Aborted Takeoff	22
PARK BRAKE Caution	22
Communications Failure.....	23

Introduction

This section provides procedures for handling abnormal system and/or flight conditions which, if followed, will maintain an acceptable level of airworthiness or reduce operational risk. The guidelines described in this section are to be used when an abnormal condition exists, and should be considered and applied as necessary.

• **WARNING** •

If a Warning annunciation is illuminated in combination with any of the following Abnormal annunciations, the Warning annunciation takes precedence and shall be performed first.

Crew Alert System (CAS) Messaging

Cautions

Displayed in yellow against a black background, Caution CAS messages arise during situations that require immediate flight crew awareness and subsequent flight crew response.

- A flashing Caution CAS message with an accompanying aural alert requires more timely flight crew response.
- A flashing Caution CAS message with no accompanying aural alert requires flight crew response, dependent on workload.
- A non-flashing Caution CAS message with no accompanying aural alert requires attention, dependent on workload. It may also require performing maintenance or taking corrective action prior to next flight.

• **NOTE** •

Crew Alerting System messages and related procedures described herein assume the aircraft is equipped with Garmin System Software 2647.N4 or later.

Advisories

Displayed in white against a black background, Advisory CAS messages arise during situations that require flight crew awareness and that may require subsequent flight crew response.

Abnormal Procedures Guidance

Although this section provides procedures for handling most abnormal system and/or flight conditions that could arise in the aircraft, it is not a substitute for proper flight training, thorough knowledge of the airplane, and recognized piloting techniques and standards. A thorough study of the information in this handbook while on the ground will help you prepare for time-critical situations in the air.

Sound judgment as well as thorough knowledge of the aircraft, its characteristics, and the flight manual procedures are essential in the handling of any abnormal system and/or flight condition. In addition to the outlined items in the Abnormal Procedures, the following steps are considered part of all abnormal situations:

- Maintain Aircraft Control
- Analyze the Situation
- Take Appropriate Action

Circuit Breakers

Some procedures involve manipulating circuit breakers (CBs). The following criteria should be followed during “Circuit Breaker” steps:

- Intentional pulling of circuit breakers during flight, other than as required in specific procedures, may cause abnormal or unexpected system behavior and is not recommended.
- When instructed to “SET”, the appropriate circuit breaker should be checked for normal condition. If the circuit breaker is not “SET”, it may be reset only once. If the circuit breaker opens again, do not reset.
- When instructed to “PULL”, the appropriate circuit breaker should only be pulled and not reset.
- When instructed to “CYCLE”, the appropriate circuit breaker should be pulled, delayed for several seconds, and reset only once. Allow sufficient cooling time for circuit breakers that are reset through a “CYCLE” procedure.

Procedure Division Symbols

For procedures requiring pilot decision, conditional steps are indented with a symbol to designate sub-sections within the procedure. On condition, the pilot makes a decision to identify the applicable sub-section. Following the initial decision, a further sub-division of the procedure may occur. In that event, one or more additional conditions guides the pilot through the remaining decisions. Once the applicable condition(s) are identified, the pilot follows the remaining steps until the indication “Procedure Complete” is reached.

The procedure symbol levels are:

- ◆ First Level
 - Second Level
 - Third Level

Landing Guidance

Land as Soon as Practicable

Extended flight is not recommended and the pilot should proceed to land the plane, but not necessarily at the first or closest landing location. The landing location and duration of flight remains at the discretion of the pilot in command, after considering all factors related to the safety of the flight. For example, landing may be deferred to an airfield which could provide post-landing maintenance procedures or malfunction investigation. The choice of airfield may be determined by the pilot with consideration to weather, runway dimensions, surface conditions, and services available. However, in no case shall a suitable landing airfield be discounted in the name of convenience.

Land as Soon as Possible

Land without delay at the first site at which a safe landing can be made. Continued flight beyond an available airfield at which a safe landing can be made will result in increased risk and shall not be attempted. The nearest suitable landing site shall be determined by the pilot with consideration given to weather, surface dimensions and conditions, and pilot experience.

Flight Environment

Inadvertent Icing Encounter

1. Pitot Heat ON
2. Exit icing conditions. Turn back or change altitude.
3. Cabin Heat MAXIMUM
4. Windshield Defrost FULL OPEN
5. Alternate Induction Air ON

Procedure Complete

• WARNING •

Flight into known icing conditions is prohibited.

Inadvertent IMC Encounter

1. Airplane Control ESTABLISH STRAIGHT AND LEVEL FLIGHT
2. Autopilot ENGAGE TO HOLD HEADING AND ALTITUDE
3. Heading RESET TO INITIATE 180° TURN

Procedure Complete

• NOTE •

Upon entering IMC, a pilot who is not completely proficient in instrument flying should rely upon the autopilot to execute a 180° turn to exit the conditions. Immediate action should be made to turn back as described above.

Door Open In Flight

1. Airplane Control MAINTAIN

Procedure Complete

• NOTE •

The doors on the airplane will remain 1-3 inches open in flight if not latched. If this is discovered on takeoff roll, abort takeoff if practical. If already airborne do not allow efforts to close the door interfere with the primary task of maintaining control of the airplane.

Abnormal Landings

Landing With Failed Brakes

◆ One brake inoperative:

- a. Land on the side of runway corresponding to the inoperative brake.
- b. Maintain directional control using rudder and working brake.

Procedure Complete

◆ Both brakes inoperative:

- a. Divert to the longest, widest runway with the most direct headwind.
- b. Land on downwind side of the runway.
- c. Use the rudder for obstacle avoidance.
- d. Perform [Emergency Engine Shutdown On Ground Checklist](#).

Procedure Complete

• NOTE •

Rudder effectiveness will decrease with decreasing airspeed.

Landing With Flat Tire

◆ Main Gear:

- a. Land on the side of the runway corresponding to the good tire.
- b. Maintain directional control with the brakes and rudder.
- c. Do not taxi. Stop airplane and perform a normal Engine [Shutdown](#).

Procedure Complete

◆ Nose Gear:

- a. Land in the center of the runway.
- b. Hold the nosewheel off the ground as long as possible.
- c. Do not taxi. Stop airplane and perform a normal Engine [Shutdown](#).

Procedure Complete

• NOTE •

If a flat tire or tread separation occurs during takeoff and you cannot abort, land as soon as conditions permit.

Engine System

OIL PRESS Caution

OIL PRESS

Low Idle Oil Pressure

◆ If in flight:

- a. Land as soon as practicable.

Procedure Complete

• NOTE •

Oil pressure between 25 psi and 55 psi at or above 1000 RPM.

This message will appear prior to engine start and should clear after engine start.

OIL TEMP Caution

OIL TEMP

High Oil Temperature

1. Power..... REDUCE AS MUCH AS PRACTICAL
2. Airspeed..... INCREASE
3. Mixture AS REQUIRED
4. Oil Temperature Gauge MONITOR

Procedure Complete

START ENGAGED Caution

START ENGAGED

Starter Engaged Annunciation

◆ If on ground:

- a. Ignition Switch..... DISENGAGE PRIOR TO 10 SECONDS
- b. Wait 30 seconds before next start attempt.

○ If starter does not disengage (relay or solenoid failure):

- (1) BAT 1 Switch OFF
- (2) Engine SHUTDOWN
- (3) STARTER Circuit Breaker..... PULL

Procedure Complete

◆ If in flight:

- a. Ignition Switch..... ENSURE NOT STUCK IN START
- b. STARTER Circuit Breaker PULL
- c. Flight..... CONTINUE

Engine start will not be available at destination.

Procedure Complete

• WARNING •

Use caution after shutdown if STARTER circuit breaker required pull (failed relay or solenoid). If breaker is unknowingly or unintentionally reset, starter will instantly engage if Battery 1 power is supplied; creating a hazard for ground personnel.

• NOTE •

Starter has been engaged for more than 15 seconds (starter limit is 10 seconds); if not manually engaged, such as during difficult start, this annunciation may indicate a failure of the starter solenoid or a stuck keyswitch.

Fuel System

FUEL LOW TOTAL Caution

FUEL LOW TOTAL

Low Fuel Quantity

1. Fuel Quantity Gauges CHECK
 2. Totalized Fuel Quantity CHECK
- ◆ If totalized value differs significantly from sensed quantity:
- a. Initial Fuel Value VERIFY AND CORRECT
- ◆ If message persists:
- a. Land as soon as practicable.

Procedure Complete

• NOTE •

Fuel totalizer or sensed fuel quantity is less than or equal to 10 gallons.

FUEL IMBALANCE Caution

FUEL IMBALANCE

Fuel Imbalance

1. Fuel Quantity Gauges CHECK
2. Fuel Pump ON
If Fuel Pump is already ON for vapor suppression, pump should be left in this position for tank switch.
3. Fuel Selector SELECT FULLER TANK
4. Fuel Pump AS REQUIRED
After switching tanks, message will remain until sensed imbalance is less than 7.5 gallons.

Procedure Complete

• NOTE •

Fuel level imbalance (between left and right) is greater than 7.5 gallons.

FUEL IMBALANCE Advisory

FUEL IMBALANCE

Fuel Imbalance

1. Fuel Quantity Gauges..... CHECK
2. Fuel Pump..... ON
If Fuel Pump is already ON for vapor suppression, pump should be left in this position for tank switch.
3. Fuel Selector..... SELECT FULLER TANK
4. Fuel Pump..... AS REQUIRED
After switching tanks, message will remain until sensed imbalance is less than 5.5 gallons.

Procedure Complete

• NOTE •

Fuel level imbalance (between left and right) is greater than 5.5 gallons.

Electrical System

M BUS 1 Caution

M BUS 1

Low Voltage on Main Bus 1

1. Perform [ALT 1 Caution \(Failure\)](#) Checklist.

Procedure Complete

• NOTE •

Main Bus 1 Voltage is low, indicates Alt 1 failure and will typically be associated with low M1 voltage Alt 1 current indications, Battery 1 discharge and [ALT 1 Caution \(Failure\)](#) message.

M BUS 2 Caution

M BUS 2

Low Voltage on Main Bus 2

1. Perform [ALT 1 Caution \(Failure\)](#) and [ALT 2 Caution \(Failure\)](#) Checklists.

Procedure Complete

• NOTE •

Main Bus 2 Voltage is low, indicative of dual Alt 1 and 2 failures and will typically be associated with low M1 and M2 voltages, Alt 1 and Alt 2 current indications, Battery 1 discharge, ALT 1 & 2 and [M BUS 1 Caution](#) & [M BUS 2 Caution](#) messages, and [ESS BUS Warning](#) message.

BATT 1 Caution

BATT 1

Unexpected discharge on battery 1.

1. Main Bus 1, 2 and Non-Essential Bus Loads REDUCE
2. Main Bus 1, 2 and Essential Bus Voltages.....MONITOR
3. Land as soon as practicable.

Procedure Complete

• NOTE •

Battery 1 discharge while Alt 1 is functioning normally, indicative of an internal power distribution failure within the MCU.

ALT 1 Caution (Failure)

ALT 1

Low Alternator 1 Output

1. ALT 1 Circuit Breaker CHECK AND SET
2. ALT 1 Switch CYCLE

◆ If alternator does not reset:

- a. ALT 1 Switch OFF
- b. Non-Essential Bus Loads REDUCE

○ If flight conditions permit, consider shedding the following to preserve Battery 1:

- (1) Air Conditioning
- (2) Landing Light
- (3) Convenience Power (aux items plugged into armrest jack)
- (4) EVS Camera (if installed)
- c. Continue Flight, avoiding IMC or night flight as able (reduced power redundancy).

Procedure Complete

• CAUTION •

Dependent on Battery 1 state (indicated by M1 voltage), landing light may be weak or inoperative for landing.

• NOTE •

Alternator 1 output is low, indicative of alternator failure and will typically be associated with low M1 voltage, Battery 1 discharge and **M BUS 1 Caution** message.

ALT 2 Caution (Failure)

ALT 2

Low Alternator 2 Output

1. ALT 2 Circuit Breaker CHECK AND SET
2. ALT 2 Switch..... CYCLE

◆ If alternator does not reset:

- a. ALT 2 SwitchOFF
- b. Continue Flight, avoiding IMC or night flight as able (reduced power redundancy).

Procedure Complete

• NOTE •

Alternator 2 output is low, indicative of alternator failure. Isolated Alt 2 failure will not typically be associated with any other unusual indications, cautions or warnings (Alt 1 will pick up all loads).

Integrated Avionics System

AVIONICS OFF Caution

AVIONICS OFF

Avionics Switch Off

1. AVIONICS Switch ON, AS REQUIRED

Procedure Complete

• NOTE •

The AVIONICS switch is off.

PFD FAN FAIL Advisory

PFD FAN FAIL

PFD Cooling Fan Failure

1. AVIONICS FAN 2 Circuit Breaker CYCLE

◆ If annunciation does not extinguish:

- a. High cabin temps LAND AS SOON AS PRACTICABLE
- b. Low cabin temps CONTINUE, MONITOR

Procedure Complete

• NOTE •

The cooling fan for the PFD is inoperative.

MFD FAN FAIL Advisory

MFD FAN FAIL

MFD Cooling Fan Failure

1. AVIONICS FAN 1 Circuit Breaker CYCLE

◆ If annunciation does not extinguish:

- a. High cabin temps LAND AS SOON AS PRACTICABLE
- b. Low cabin temps CONTINUE, MONITOR

Procedure Complete

• NOTE •

The cooling fan for the MFD is inoperative.

Flight Displays Too Dim

1. INSTRUMENT dimmer knobOFF
(FULL COUNTER-CLOCKWISE)

- ◆ If flight displays do not provide sufficient brightness:
 - a. Revert to standby instruments.

Procedure Complete

• NOTE •

The instrument dimmer knob provides manual dimming control of the display screens, key and text backlighting, flap and Environmental Control System (ECS) status indicators, and standby instruments. Rotation of the dimmer knob fully counterclockwise disables the dimmer, and reverts to daytime lighting for all components. In the event of a dimmer control circuit failure, or to override the manual dimming circuit, pull the CABIN LIGHTS circuit breaker.

In daytime lighting (knob OFF/full counterclockwise, or with CABIN LIGHTS circuit breaker pulled):

- Electro-mechanical standby instruments, all avionics system keypads and the bolster switch panel are unlit
- MFD, PFD, and MD302 Standby Attitude Module (optional) screen illumination is controlled by automatic photocell (providing full brightness in high light conditions, only slightly reduced by darkness)
- ECS and control panels are backlit and their status lights are at maximum intensity

With active dimming (knob moved clockwise), the full bright position (full clockwise) applies maximum illumination to keys and switches, to standby instruments and to status lights, but the PFD, MFD, and MD302 Standby Attitude Module (optional) screen illumination is at a substantially reduced level (levels still appropriate for night flight). Maximum screen illumination (appropriate for daytime use) is with the dimmer OFF/full counterclockwise.

Pitot Static System

Static Source Blocked

1. Pitot Heat ON
2. Alternate Static Source OPEN

Procedure Complete

• NOTE •

If erroneous readings of the static source instruments (airspeed, altimeter and vertical speed) are suspected, the alternate static source valve, on side of console near pilot's right ankle, should be opened to supply static pressure from the cabin to these instruments. With the alternate static source on, adjust indicated airspeed slightly during climb or approach in accordance with Section 5, [Alternate Static Source](#) as appropriate for vent/ heater configuration.

Pitot Tube Blocked

1. Pitot Heat ON

Procedure Complete

• NOTE •

If only the airspeed indicator is providing erroneous information, and in icing conditions, the most probable cause is Pitot ice. If setting Pitot Heat ON does not correct the problem, descend to warmer air. If an approach must be made with a blocked Pitot tube, use known pitch and power settings and the GPS ground speed indicator, taking surface winds into account.

PITOT HEAT FAIL Caution

PITOT HEAT FAIL

Pitot Heat Current Sensor

1. Pitot Heat Circuit Breaker CYCLE
2. Pitot Heat.....CYCLE OFF, ON

◆ If inadvertent icing encountered, perform [Inadvertent Icing Encounter Checklist](#) and:

- a. Airspeed EXPECT NO RELIABLE INDICATION
- b. Exit icing conditions using attitude, altitude, and power instruments.

Procedure Complete

• NOTE •

Pitot heat failure. Displayed when Pitot heat switch is ON and Pitot heat current is not detected.

PITOT HEAT REQD Caution

PITOT HEAT REQD

Pitot Heat Required

1. Pitot Heat..... ON

Procedure Complete

• NOTE •

Displayed 15 seconds after system detects OAT is less than 41 °F (5 °C) and Pitot Heat Switch is OFF.

Flight Control System

Electric Trim/Autopilot Failure

1. Airplane Control MAINTAIN MANUALLY
2. Autopilot (if engaged) DISENGAGE

◆ If Problem Is Not Corrected:

- a. Circuit Breakers PULL AS REQUIRED
 - PITCH TRIM
 - ROLL TRIM
 - AP SERVOS
- b. Power Lever AS REQUIRED
- c. Control Yoke MANUALLY HOLD PRESSURE
- d. Land as soon as practicable.

Procedure Complete

• NOTE •

Any failure or malfunction of the electric trim or autopilot can be overridden by use of the control yoke. If runaway trim is the problem, deenergize the circuit by pulling the appropriate circuit breakers and land as soon as conditions permit.

FLAPS OVERSPEED Caution

FLAPS OVERSPEED

Flap System Exceedance

1. Airspeed REDUCE
OR
1. Flaps RETRACT

Procedure Complete

• NOTE •

Flaps are extended beyond airspeed limitations.

Flaps at 100%, airspeed greater than 115 KIAS for 5 seconds or more,

OR

Flaps at 50%, airspeed greater than 155 KIAS for 5 seconds or more.

TAKEOFF FLAPS Caution

TAKEOFF FLAPS

Flaps Not In Takeoff Configuration

1. Takeoff ABORT
2. Aircraft Control MAINTAIN
3. Aircraft Configuration CHECK

Procedure Complete

• NOTE •

Flaps are not set to 50% during takeoff.

FLAPS CLIMB Advisory

FLAPS CLIMB

Flaps Not Set For Climb

1. Flaps UP

Procedure Complete

• NOTE •

Flaps are not set for enroute climb.

Landing Gear System

Brake Failure During Taxi

1. Engine Power..... AS REQUIRED
To stop airplane - REDUCE
If necessary for steering - INCREASE
 2. Directional Control MAINTAIN WITH RUDDER
 3. Brake Pedal(s).....PUMP
- ◆ If directional control cannot be maintained:
- a. Ignition Switch..... OFF

Procedure Complete

• NOTE •

Ground steering is accomplished by differential braking.
However, increasing power may allow some rudder control due to increased ground speed and airflow over the rudder.

BRAKE TEMP Caution

BRAKE TEMP

Left/Right Brake Over-Temperature

1. Stop aircraft and allow the brakes to cool.

Procedure Complete

• WARNING •

Do not set parking brake unless required for safety.

• NOTE •

Brake temperature is between 270 °F and 293 °F for more than 5 seconds. Refer to Section 10, [Taxiing, Steering, and Braking Practices](#) for additional information.

Other Conditions

Aborted Takeoff

1. Power Lever..... IDLE
2. Brakes..... AS REQUIRED

Procedure Complete

• NOTE •

Use as much of the remaining runway as needed to safely bring the airplane to a stop or to slow the airplane sufficiently to turn off runway.

• CAUTION •

For maximum brake effectiveness, retract flaps, hold control yoke full back, and bring the airplane to a stop by smooth, even application of the brakes.

After a high-speed aborted takeoff, brake temperatures will be elevated. Subsequent aborted takeoffs or other high-energy use of the brakes may cause brake overheat, failure and possibly even fire. A 25-minute cooling time is recommended following high-energy use of the brake system before attempting to conduct operations that may require further high-energy braking. Brake temperature indicator should be inspected prior to flight following a high-energy brake event. Refer to Section 4, [Preflight Inspection Checklist](#) for additional detail.

PARK BRAKE Caution

PARK BRAKE

Parking Brake Engaged Annunciation

1. Parking Brake..... RELEASE
2. Monitor CAS for BRAKE TEMP Caution. Stop aircraft and allow the brakes to cool if necessary.

Procedure Complete

• NOTE •

Parking brake is set.

Communications Failure

1. Switches, Controls CHECK
2. Frequency.....CHANGE
3. Circuit Breakers.....SET
4. HeadsetCHANGE
5. Handheld Microphone (if installed) CONNECT

Procedure Complete

• NOTE •

If, after following the checklist procedure, communication is not restored, proceed with CFR/AIM lost communications procedures.

In the event of an audio panel power failure the audio panel connects COM 1 to the pilot's headset and speakers. Setting the audio panel 'Off' will also connect COM 1 to the pilot's headsets and speakers.

Intentionally Left Blank

Section 4: Normal Procedures

Table of Contents

Introduction.....	3
Airspeeds for Normal Operation.....	3
Normal Procedures	4
Preflight Inspection.....	4
Before Engine Start.....	9
Engine Start.....	10
Before Taxiing	11
Taxiing.....	12
Before Takeoff.....	13
Maximum Power Fuel Flow	15
Takeoff	15
Normal Takeoff.....	16
Short Field Takeoff	16
Climb	17
Cruise	18
Cruise Leaning	20
Descent	21
Before Landing	21
Landing.....	21
Normal Landing	21
Short Field Landing	22
Crosswind Landing.....	22
Balked Landing/Go-Around	22
After Landing	23
Shutdown	23
Stalls.....	24
Environmental Conditions	25
Cold Weather Operation.....	25
Starting	25
Hot Weather Operation	27
Ground Operation of Air Conditioning System (Optional).....	27
Extended Ground Operation	27
Lead Reduction Before Shut Down	28
Noise Characteristics/Abatement	29
Fuel Conservation	29

Intentionally Left Blank

Introduction

This section provides amplified procedures for normal operation of the Cirrus Design SR20 aircraft.

• NOTE •

Refer to [Section 9: Log of Supplements](#) for optional equipment Normal Procedures.

Airspeeds for Normal Operation

Unless otherwise noted, the following speeds are based on a maximum weight of 3150 lb. and may be used for any lesser weight. However, to achieve the performance specified in Section 5 for takeoff and landing distance, the speed appropriate to the particular weight must be used.

Takeoff:

- Normal, Flaps 50% 71-75 KIAS
- Short Field, Flaps 50% 71 KIAS
- Obstacle Clearance, Flaps 50% 81 KIAS

Enroute Climb, Flaps Up:

- Normal, SL 96 KIAS
- Normal, 10,000' 92 KIAS
- Best Rate of Climb, SL 96 KIAS
- Best Rate of Climb, 10,000' 92 KIAS

Landing Approach:

- Normal Approach, Flaps Up 89 KIAS
- Normal Approach, Flaps 50% 84 KIAS
- Normal Approach, Flaps 100% 78 KIAS
- Short Field, Flaps 100% 78 KIAS

Go-Around, Flaps 50%:

- Full Power 81 KIAS

Maximum Recommended Turbulent Air Penetration:

- 3150 Lb 133 KIAS
- 2700 Lb 123 KIAS
- 2300 Lb 114 KIAS

Maximum Demonstrated Crosswind Velocity:

- Takeoff or Landing 20 Knots

Normal Procedures

Preflight Inspection

• **WARNING** •

Before carrying out preflight inspections, ensure that all required maintenance has been accomplished. Review your flight plan and compute weight and balance and performance requirements. Throughout the walk-around: check all hinges, hinge pins, and bolts for security; check skin for damage, condition, and evidence of delamination; check all control surfaces for proper movement and excessive free play; check area around liquid reservoirs and lines for evidence of leaking.

In cold weather, remove all frost (polished or not), ice, snow, or slush from fuselage, wing, stabilizers, and control surfaces. Ensure that control surfaces are free of internal ice or debris. Check that wheel fairings are free of snow and ice accumulation. Check that Pitot probe warms within 30 seconds of setting Pitot Heat to ON.

Failure to comply may result in significant aircraft damage, loss of aircraft, and/or loss of life.

Figure 4-1: Recommended Walk-Around Sequence

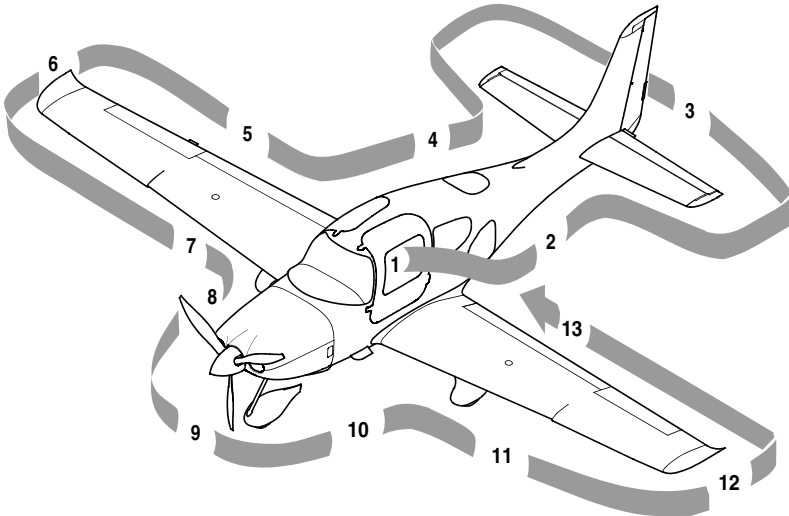

(Continued on next page)

(Continued)

1. Cabin

- a. Required Documents ON BOARD
- b. AVIONICS Switch OFF
- c. BAT 2 Switch..... ON
- d. PFD VERIFY ON
- e. Essential Bus Voltage 23-25 VOLTS
- f. Flap Position LightOUT
- g. BAT 1 Switch..... ON
- h. Avionics Cooling Fan..... AUDIBLE
- i. AVIONICS Switch ON
- j. Fuel Quantity CHECK
- k. Fuel Selector SELECT FULLER TANK
- l. Flaps..... 100%, CHECK LIGHT ON
- m. Lights CHECK OPERATION
- n. Stall Warning System Inlet..... UNOBSTRUCTED
- o. Stall Warning..... TEST

• NOTE •

Test stall warning system by applying suction to the stall warning system inlet and noting the warning horn sounds.

- p. Pitot Heat..... ON

• WARNING •

Pitot Heat Probe may be hot.

(1) Verify probe is hot.

- q. Pitot Heat..... OFF
- r. AVIONICS Switch OFF
- s. BAT 1 and BAT 2 Switches OFF
- t. Alternate Static Source..... NORMAL
- u. Circuit Breakers IN
- v. Fire Extinguisher CHARGED AND AVAILABLE
- w. Emergency Egress Hammer AVAILABLE
- x. CAPS Handle PIN REMOVED

(Continued on next page)

(Continued)

- 2. Left Fuselage
 - a. Door LockUNLOCK
 - b. COM 1 Antenna (top)..... CONDITION AND ATTACHMENT
 - c. Transponder Antenna (underside) CONDITION AND ATTACHMENT
 - d. COM 2 Antenna (underside) CONDITION AND ATTACHMENT
 - e. Wing/Fuselage FairingCHECK
 - f. Baggage DoorCLOSED AND SECURE
 - g. Static ButtonCHECK FOR BLOCKAGE
 - h. Parachute Cover..... SEALED AND SECURE
 - 3. Empennage
 - a. Tiedown RopeREMOVE
 - b. Horizontal and Vertical StabilizersCONDITION
- NOTE •**
- Verify tape covering the forward and aft inspection holes located on outboard ends of horizontal stabilizer is installed and securely attached.
- c. Elevator and Tab CONDITION AND MOVEMENT
 - d. Rudder FREEDOM OF MOVEMENT
 - e. Rudder Trim TabCONDITION AND SECURITY
 - f. Attachment hinges, bolts, and cotter pins.....SECURE
4. Right Fuselage
 - a. Static ButtonCHECK FOR BLOCKAGE
 - b. Wing/Fuselage Fairings..... CHECK
 - c. Door LockUNLOCK
5. Right Wing Trailing Edge
 - a. Flap and Rub Strips (if installed) CONDITION AND SECURITY
 - b. Aileron and TabCONDITION AND MOVEMENT
 - c. Aileron Gap Seal SECURITY

(Continued on next page)

(Continued)

• NOTE •

Verify bolt located under the inboard edge of aileron is secured with safety wire.

- d. Hinges, actuation arm, bolts, and cotter pins..... SECURE
- 6. Right Wing Tip
 - a. Tip..... ATTACHMENT
 - b. Wing Tip Light and Lens..... CONDITION AND SECURITY
 - c. Fuel Vent (underside)..... UNOBSTRUCTED
- 7. Right Forward Wing and Main Gear
 - a. Leading Edge and Stall Strips..... CONDITION
 - b. Fuel Cap CHECK QUANTITY AND SECURE
 - c. Fuel Drains (2 underside)..... DRAIN AND SAMPLE
 - d. Wheel Fairings SECURITY, ACCUMULATION OF DEBRIS
 - e. Tire..... CONDITION, INFLATION, AND WEAR
 - f. Wheel and Brakes FLUID LEAKS, EVIDENCE OF OVERHEATING, GENERAL CONDITION, AND SECURITY
 - g. Chocks and Tiedown Ropes..... REMOVE
- 8. Nose, Right Side

• CAUTION •

The engine must not be operated with less than six quarts of oil in the sump (dipstick indication). Seven quarts is recommended for extended flights.

- a. Engine Oil CHECK 6-7 QUARTS, LEAKS
- b. Engine Oil Dipstick/Filler Cap & Door SECURE
- c. Ice Inspection Light..... CONDITION AND SECURITY
- d. Cowling..... ATTACHMENTS SECURE
- e. Exhaust Pipe..... CONDITION, SECURITY, AND CLEARANCE

(Continued on next page)

(Continued)

9. Nose Gear, Propeller, and Spinner

• **WARNING** •

Keep clear of propeller rotation plane. Do not allow others to approach propeller.

- a. Tow Bar REMOVE AND STOW
- b. Strut..... CONDITION
- c. Wheel Fairing SECURITY, ACCUMULATION OF DEBRIS
- d. Wheel and Tire CONDITION, INFLATION, AND WEAR
- e. Propeller CONDITION (INDENTATIONS, NICKS, ETC.)
- f. Spinner CONDITION, SECURITY, AND OIL LEAKS
- g. Air Inlets..... UNOBSTRUCTED

10. Nose, Left Side

- a. Ice Inspection Light CONDITION AND SECURITY
- b. Cowling ATTACHMENTS SECURE
- c. External Power DOOR SECURE
- d. Gascolator (underside)..... DRAIN FOR 3 SECONDS, SAMPLE

11. Left Main Gear and Forward Wing

- a. Wheel Fairings..... SECURITY, ACCUMULATION OF DEBRIS
- b. Tire CONDITION, INFLATION, AND WEAR
- c. Wheel and Brakes FLUID LEAKS, EVIDENCE OF OVERHEATING, GENERAL CONDITION, AND SECURITY
- d. Chocks and Tiedown Ropes REMOVE
- e. Fuel Drains (2 underside) DRAIN AND SAMPLE
- f. Fuel Cap CHECK QUANTITY AND SECURE
- g. Leading Edge and Stall Strips CONDITION

12. Left Wing Tip

- a. Fuel Vent (underside) UNOBSTRUCTED
- b. Pitot Probe COVER REMOVED, UNOBSTRUCTED
- c. Wing Tip Light and Lens CONDITION AND SECURITY
- d. Tip ATTACHMENT

(Continued on next page)

(Continued)

13. Left Wing Trailing Edge

• NOTE •

Verify bolt located under the inboard edge of aileron is secured with safety wire.

- a. Hinges, actuation arm, bolts, and cotter pins.....SECURE
- b. Aileron Gap Seal SECURITY
- c. AileronFREEDOM OF MOVEMENT
- d. Flap and Rub Strips (if installed).... CONDITION AND SECURITY

Before Engine Start

- 1. Preflight Inspection COMPLETED

• WARNING •

Ensure that the airplane is properly loaded and within the AFM's weight and balance limitations prior to takeoff.

- 2. Weight and Balance VERIFY WITHIN LIMITS
- 3. Emergency Equipment..... ON BOARD
- 4. PassengersBRIEFED

• NOTE •

Ensure all the passengers have been fully briefed on smoking, the use of the seat belts, doors, emergency exits, egress hammer, and CAPS.

Verify CAPS handle safety pin is removed.

- 5. Seats, Seat Belts, and HarnessesADJUST AND SECURE

• WARNING •

Crew seats must be locked in position and control handles fully down before flight. Ensure seat belt harnesses are not twisted.

Engine Start

If the engine is warm, no priming is required. For the first start of the day and in cold conditions, prime will be necessary.

Weak intermittent firing followed by puffs of black smoke from the exhaust stack indicates over-priming or flooding. Excess fuel can be cleared from the combustion chambers by the following procedure:

- Turn fuel pump off.
- Allow fuel to drain from intake tubes.
- Set the mixture control to CUTOFF and the power lever to 1/2 open position.
- Crank the engine through several revolutions with the starter.
- When the engine starts, release ignition switch, smoothly advance the mixture control to RICH, and promptly retard the power lever.

If the engine is under-primed, especially with a cold soaked engine, it will not fire, and additional priming will be necessary. As soon as the cylinders begin to fire, open the power lever slightly to keep it running. Refer to [Cold Weather Operation](#) in this section or additional information regarding cold weather operations.

• WARNING •

If airplane will be started using external power, keep all personnel and power unit cables well clear of the propeller rotation plane.

• CAUTION •

Alternators should be left OFF during engine starting to avoid high electrical loads.

After starting, if the oil gauge does not begin to show pressure within 10 seconds, shut down engine and investigate cause. Lack of oil pressure indicates loss of lubrication, which can cause severe engine damage.

(Continued on next page)

(Continued)

1. External Power (If applicable)..... CONNECT
2. BrakesHOLD
3. BAT 1 and BAT 2 Switches ON (CHECK VOLTS)
4. Strobe Lights..... ON
5. Power Lever OPEN ¼ INCH
6. Mixture..... CUTOFF
7. Propeller Area..... CLEAR
8. Fuel Pump..... ON
9. Mixture..... ADVANCE TO RICH
UNTIL STABLE FUEL FLOW IS INDICATED (3-5 SECONDS)
10. Mixture..... CUTOFF
11. Ignition Switch START (RELEASE AFTER ENGINE STARTS)

• CAUTION •

Limit cranking to intervals of 10 seconds with a 30-second cooling period between cranks. This will improve battery and contactor life.

12. Mixture..... SMOOTHLY ADVANCE TO RICH
(AFTER ENGINE STARTS)
13. Power Lever RETARD (MAINTAIN 1000 RPM)
14. Oil Pressure..... CHECK
15. Fuel Pump..... OFF
16. ALT 1 and ALT 2 Switches..... ON
17. AVIONICS Switch..... ON
18. Engine Parameters MONITOR
19. External Power (If applicable)..... DISCONNECT

Before Taxiing

1. Flaps..... UP (0%)
2. Radios/Avionics AS REQUIRED
3. Cabin Heat/Defrost AS REQUIRED
4. Fuel Selector..... SWITCH TANK

Taxiing

When taxiing, directional control is accomplished with rudder deflection and intermittent braking (toe taps) as necessary. Use only as much power as is necessary to achieve forward movement. Deceleration or taxi speed control using brakes but without a reduction in power will result in increased brake temperature. Taxi over loose gravel at low engine speed to avoid damage to the propeller tips.

• **WARNING** •

Maximum continuous engine speed for taxiing is 1000 RPM on flat, smooth, hard surfaces. Power settings slightly above 1000 RPM are permissible to start motion, for turf, soft surfaces, and on inclines. Use minimum power to maintain taxi speed.

If the 1000 RPM taxi power limit and proper braking procedures are not observed, the brake system may overheat and result in brake damage or brake fire.

• **CAUTION** •

Avoid prolonged idling and do not exceed 2200 RPM on the ground. The engine is warm enough for takeoff when the throttle can be opened without the engine faltering.

1. Parking Brake..... DISENGAGE
2. Brakes..... CHECK
3. HSI Orientation..... CHECK
4. Attitude Gyro..... CHECK
5. Turn Coordinator CHECK

Before Takeoff

During cold weather operations, the engine should be properly warmed up before takeoff. In most cases this is accomplished when the oil temperature has reached at least 100 °F (38 °C). In warm or hot weather, precautions should be taken to avoid overheating during prolonged ground engine operation. Additionally, long periods of idling may cause fouled spark plugs.

• **WARNING** •

Do not takeoff with frost, ice, snow, or other contamination on the fuselage, wing, stabilizers, and control surfaces.

1. Doors LATCHED
2. CAPS Handle VERIFY PIN REMOVED
3. Seat Belts and Shoulder Harness SECURE
4. ECS Control Panel SET
5. Air Conditioner RECIRC DISABLED

• **CAUTION** •

Use of RECIRC mode prohibited in flight.

• **NOTE** •

If Air Conditioner is ON for takeoff roll, see Section 5, [Takeoff Distance](#) for takeoff distance change. No takeoff distance change is necessary if system remains OFF for takeoff roll. Airflow Selector should not be set to OFF, unless otherwise specified by a procedure.

6. Fuel Quantity CONFIRM
7. Fuel Selector FULLER TANK
8. Flaps SET 50% AND CHECK
9. Autopilot CHECK AND DISCONNECT
10. Transponder SET
11. COM and NAV/GPS SET
12. Brakes HOLD
13. Mixture AS REQUIRED
14. Power Lever 2200 RPM

(Continued on next page)

(Continued)

- 15. Alternator CHECK
 - a. Pitot Heat ON
 - b. Navigation Lights ON
 - c. Landing Light ON
- 16. Voltage CHECK
- 17. Pitot Heat AS REQUIRED

• NOTE •

Pitot Heat should be turned ON for flight into IMC, flight into visible moisture, or whenever ambient temperatures are 41 °F (5 °C) or less.

- 18. Navigation Lights AS REQUIRED
- 19. Landing Light AS REQUIRED
- 20. Magnetos CHECK LEFT AND RIGHT
 - a. Ignition Switch R, NOTE RPM, THEN BOTH
 - b. Ignition Switch L, NOTE RPM, THEN BOTH

• NOTE •

RPM drop must not exceed 175 RPM for either magneto. RPM differential must not exceed 50 RPM between magnetos. If there is a doubt concerning operation of the ignition system, RPM checks at higher engine speeds will usually confirm whether a deficiency exists.

An absence of RPM drop may indicate faulty grounding of one side of the ignition system or magneto timing set in advance of the specified setting.

- 21. Engine Parameters CHECK
- 22. Power Lever IDLE

• NOTE •

Verify smooth engine operation at idle speed of 700 to 750 RPM.

- 23. Power Lever 1000 RPM
- 24. Fuel Pump ON
- 25. Flight Instruments, HSI, and Altimeter CHECK AND SET
- 26. Flight Controls FREE AND CORRECT
- 27. Trim SET TAKEOFF
- 28. CAS Messages CHECK

Maximum Power Fuel Flow

Target fuel flow is indicated by the top of a dynamically calculated green arc displayed on the fuel flow gauge. Full Power target fuel flow should be maintained at the top of this arc by use of the mixture lever.

The fuel flow values in the table below were demonstrated to obtain the takeoff and climb performance presented in Section 5 at ISA standard conditions.

Altitude	Target Fuel Flow GPH
0	20
4000	18
8000	16
12000	15
16000	13

• CAUTION •

Excessively rich mixture will occur if the mixture control is set to FULL RICH above 5000 feet density altitude

Takeoff

• NOTE •

Ensure mixture is appropriate for field density altitude.

Fuel flow at full throttle should be at the top of the green arc on the fuel flow gauge.

Power Check: Check full-throttle engine operation early in takeoff run. The engine should run smoothly and turn approximately 2700 RPM. Verify all engine parameters are not in caution or warning ranges. Discontinue takeoff at any sign of rough operation or sluggish acceleration. Make a thorough full-throttle static run-up before attempting another takeoff.

For takeoff over a gravel surface, advance Power Lever slowly. This allows the airplane to start rolling before high RPM is developed, and gravel will be blown behind the propeller rather than pulled into it.

Flap Settings: Normal and short field takeoffs are accomplished with flaps set at 50%. Takeoffs with 100% flaps are not approved.

Soft or rough field takeoffs are performed with 50% flaps by lifting the airplane off the ground as soon as practical in a tail-low attitude. If no obstacles are ahead, the airplane should be leveled off immediately to accelerate to a higher climb speed.

Takeoffs into strong crosswinds are normally performed with the flaps set at 50% to minimize the drift angle immediately after takeoff. With the ailerons fully deflected into the wind, accelerate the airplane to a speed slightly higher than normal while decreasing the aileron deflection as speed increases then - with authority - rotate to prevent possibly settling back to the runway while drifting. When clear of the ground, make a coordinated turn into the wind to correct for drift.

• NOTE •

Fuel Pump should be left ON during takeoff and for climb.

Normal Takeoff

1. Brakes..... RELEASE (STEER WITH RUDDER ONLY)
2. Power Lever.....FULL FORWARD

• WARNING •

Abrupt full range throttle movement can result in engine damage. Idle to maximum power throttle movements should be made slowly (approximately 3 seconds for full range motion). Abrupt full range power lever movements can also accentuate overly rich mixture settings resulting in poor throttle response.

3. Engine ParametersCHECK
4. Elevator ControlROTATE SMOOTHLY AT 71-75 KIAS
5. At 85 KIAS, FlapsUP

Short Field Takeoff

1. Flaps 50%
2. Brakes..... HOLD
3. Power Lever.....FULL FORWARD
4. Engine ParametersCHECK
5. Brakes..... RELEASE (STEER WITH RUDDER ONLY)
6. Elevator Control ROTATE SMOOTHLY AT 71 KIAS
7. Airspeed at Obstacle 81 KIAS
When clear of obstacle:
8. FlapsUP

Climb

Normal climbs are performed flaps UP (0%) and full power at speeds 5 to 10 knots higher than best rate-of-climb speeds. These higher speeds give the best combination of performance, visibility and engine cooling.

For maximum rate of climb, use the best rate-of-climb speeds shown in the rate-of-climb chart in Section 5. If an obstruction dictates the use of a steep climb angle, the best angle-of-climb speed should be used. Climbs at speeds lower than the best rate-of-climb speed should be of short duration to avoid engine-cooling problems.

1. Climb PowerSET
2. Flaps VERIFY UP
3. Mixture LEAN AS REQUIRED FOR ALTITUDE
4. Engine Parameters CHECK
5. Fuel Pump AS REQUIRED

• CAUTION •

Fuel Pump should be left ON during takeoff and for climb as required for vapor suppression with hot or warm fuel.

Fuel flow at full throttle should be at the top of the green arc on the fuel flow gauge.

Cruise

Normal cruising is performed between 55% and 85% power. The engine power setting and corresponding fuel consumption for various altitudes and temperatures can be determined by using the cruise data in Section 5. The selection of cruise altitude is made based on the most favorable wind conditions and the desired power settings. These significant factors should be considered on every trip to reduce fuel consumption.

• NOTE •

Mineral oil should be used for the first 50 hours of engine operation or until oil consumption stabilizes.

An engine break-in is done to seat the piston rings and stabilize oil consumption. During the break-in period, it is important to keep the engine temperatures as cool as reasonably possible, while operating at a higher power setting. Engine operation at power settings between 65% and 75% power are recommended. To aid in keeping engine temperatures cool, it is recommended to operate the engine at best power fuel flows or slightly richer for the first 50 hours of engine operation, or until oil consumption stabilizes.

During break-in, make sure the engine is operated at 65% or higher cruise power as much as practical to ensure correct piston ring seating. Cruise power of 75% for the first hour of flight, and alternating power settings between 65% and 75% power for the second hour of flight, is recommended for proper engine break-in. Engine operation below 65% cruise power during engine break-in can cause poor engine performance.

Avoid engine operation with low manifold pressure and high engine RPM. Manifold pressures less than 15 in.Hg with high engine RPM should be avoided when possible to do so. When possible avoid rapid changes in the throttle setting. These conditions can cause damage to the counterweights, rollers or bushings, and cause detuning.

Do not do closed throttle descents which can cause ring flutter and damage to the cylinders and piston rings.

Operate the engine at cruise power at lower altitudes for engine break-in. Density altitude in excess of 8,000 feet (2438 m) will prevent the engine from reaching sufficient cruise power for an acceptable break-in. An altitude of 5,000 feet (1524 m) is recommended.

(Continued on next page)

(Continued)

1. Fuel Pump OFF

• NOTE •

The Fuel Pump may be used for vapor suppression during cruise.

The Fuel Pump should be set to ON during maneuvering flight
(flight training maneuvers, chandelles, stalls, etc.).

2. Cruise Power SET
3. Mixture LEAN AS REQUIRED
4. Engine Parameters MONITOR
5. Fuel Flow and Balance MONITOR

Cruise Leaning

• CAUTION •

If moving the mixture control from the full rich position only decreases the EGT from the full rich value, place the mixture control back in the full forward position and have the fuel system serviced.

Exhaust gas temperature (EGT) may be used as an aid for mixture leaning in cruise flight.

• NOTE •

Engine can be leaned for Best Power Cruise at any power setting. For Best Economy use 75% power or less. For best durability, use 85% or less at best power.

To adjust the mixture, lean to establish the peak EGT as a reference point and then adjust the mixture by the desired increment based on the following table:

Mixture Description	Exhaust Gas Temperature
Best Power	100 °F Rich Of Peak EGT
Best Economy	Between Peak EGT and 50 °F Lean Of Peak EGT, depending on ambient conditions (ensuring no misfire)

Alternatively, leaning can be done by adjusting the mixture to the cyan Target Fuel Flow caret displayed on the fuel flow gauge.

Target Fuel Flow is determined using a calculated engine air flow based on engine speed, manifold air temperature and manifold air pressure.

Target Fuel Flow is advisory only and does not guarantee sufficient cylinder cooling. If any CHT's are greater than 435 °F enrich the mixture to aid in cooling. Under some conditions, engine roughness may occur while operating at best economy. If this occurs, enrich mixture as required to smooth engine operation. Any change in altitude or Power Lever position will require a recheck of EGT indication.

Descent

1. AltimeterSET
2. Cabin Heat/Defrost AS REQUIRED
3. Landing Light ON
4. Fuel System CHECK
5. Mixture AS REQUIRED
6. Brake Pressure CHECK

Before Landing

1. Seat Belt and Shoulder Harness SECURE
2. Fuel Pump ON
3. Mixture AS REQUIRED
4. Flaps AS REQUIRED
5. Autopilot AS REQUIRED

• CAUTION •

The mixture should be set such that fuel flow is at the top of the green arc on the fuel flow gauge when the throttle is advanced to wide open. This mixture position is approximately equivalent to the cyan target when at reduced power settings.

Landing

• CAUTION •

Landings should be made with full flaps. Landings with less than full flaps are recommended only if the flaps fail to deploy or to extend the aircraft's glide distance due to engine malfunction. Landings with flaps at 50% or 0%: power should be used to achieve a normal glide path and low descent rate. Flare should be minimized.

Normal Landing

1. Flaps 100%
 2. Airspeed 81-83 KIAS
 3. Power Lever AS REQUIRED
- After touchdown:
4. Brakes AS REQUIRED

Short Field Landing

1. Flaps 100%
2. Airspeed.....78 KIAS
3. Power Lever.....AS REQUIRED
After clear of obstacles:
4. Power Lever.....REDUCE TO IDLE
After touchdown:
5. Brakes.....AS REQUIRED

Crosswind Landing

Normal crosswind landings are made with full flaps. Avoid prolonged slips. After touchdown, hold a straight course with rudder and brakes as required.

The maximum allowable crosswind velocity is dependent upon pilot capability as well as aircraft limitations. Operation in direct crosswinds of 20 knots has been demonstrated.

Balked Landing/Go-Around

In a balked landing (go-around) climb, disengage autopilot, apply full power, then reduce the flap setting to 50%. If obstacles must be cleared during the go-around, climb at the best angle of climb with 50% flaps. After clearing any obstacles, retract the flaps and accelerate to the normal flaps-up climb speed.

• WARNING •

Abrupt full range power lever movement can result in engine damage. Idle to maximum power movements of the power lever should be made slowly (approximately 3 seconds for full range motion). Abrupt full range power lever movements can also accentuate overly rich mixture settings resulting in poor throttle response.

1. Autopilot DISENGAGE
2. Power Lever.....FULL FORWARD
3. Flaps 50%
4. Airspeed.....BEST ANGLE OF CLIMB (81 KIAS)
After clear of obstacles:
5. Flaps UP

After Landing

1. Power Lever 1000 RPM
2. Fuel Pump OFF
3. Flaps UP
4. Lights AS REQUIRED
5. Pitot Heat OFF

• NOTE •

As the airplane slows, the rudder becomes less effective and taxiing is accomplished using differential braking.

Shutdown

1. Fuel Pump OFF
2. Power Lever IDLE
3. Mixture CUTOFF
4. All Switches OFF
5. Magnetos OFF
6. ELT TRANSMIT LIGHT OUT

• NOTE •

After a hard landing, ELT may activate. if this is suspected, press the RESET button.

7. Chocks, Tie-downs, Pitot Covers AS REQUIRED

Stalls

Aircraft stall characteristics are conventional. Power-off stalls may be accompanied by a slight nose bobbing if full aft stick is held. Power-on stalls are marked by a high sink rate at full aft stick. Power-off stall speeds at maximum weight for both forward and aft CG positions are presented in Section 5 - [Stall Speeds](#).

When practicing stalls at altitude, as the airspeed is slowly reduced, you will notice a slight airframe buffet, hear the stall speed warning horn sound between 5 and 10 knots before the stall, and see the Crew Alerting System display a STALL Warning annunciation. Normally, the stall is marked by a gentle nose drop and the wings can easily be held level or in the bank with coordinated use of the ailerons and rudder. Upon stall warning in flight, recovery is accomplished by immediately reducing back pressure to reduce the angle of attack and to maintain safe airspeed, adding power if necessary and rolling wings level with coordinated use of the controls.

• WARNING •

Use care to avoid uncoordinated, abrupt or abused control inputs when close to stall.

Abrupt full range power lever movement can result in engine damage. Idle to maximum power movements of the power lever should be made slowly (approximately 3 seconds for full range motion). Abrupt full range power lever movements can also accentuate overly rich mixture settings resulting in poor throttle response.

Environmental Conditions

Cold Weather Operation

• CAUTION •

An engine that has been superficially warmed, may start and appear to run satisfactorily, but can be damaged from lack of lubrication due to the congealed oil blocking proper oil flow through the engine. The amount of damage will vary and may not become evident for many hours. However, the engine may be severely damaged and may fail shortly following application of high power. Proper procedures require thorough application of preheat to all parts of the engine. Hot air must be applied directly to the oil sump and external oil lines as well as the cylinders, air intake and oil cooler. Because excessively hot air can damage non-metallic components such as composite parts, seals, hoses, and drive belts, do not attempt to hasten the preheat process.

Starting

When the engine has been exposed to temperatures below 10 °F (-12 °C) for a period of two hours or more, the use of an external pre-heater and external power is recommended. Failure to properly preheat a cold-soaked engine may result in oil congealing within the engine, oil hoses, and oil cooler with subsequent loss of oil flow, possible internal damage to the engine, and subsequent engine failure.

If the engine does not start during the first few attempts, or if engine firing diminishes in strength, the spark plugs have probably frosted over. Preheat must be used before another start is attempted.

• NOTE •

When the oil temperature has reached 100 °F (38 °C) and oil pressure does not exceed 70 psi at 2500 RPM, the engine has been warmed sufficiently to accept full rated power.

1. External Power (If applicable)..... CONNECT
2. BrakesHOLD
3. BAT 1 and BAT 2 Switches ON (CHECK VOLTS)
4. Strobe Lights..... ON

(Continued on next page)

(Continued)

- 5. Power Lever..... OPEN ¼ INCH
- 6. Mixture CUTOFF
- 7. Propeller Area..... CLEAR
- 8. Fuel Pump ON
- 9. Mixture ADVANCE TO RICH UNTIL STABLE FUEL FLOW IS INDICATED (3-5 SECONDS)

• NOTE •

In temperatures below 20 °F (-7 °C), mixture can remain in RICH position for 5 - 10 seconds before moving to CUTOFF.

- 10. Mixture CUTOFF
- 11. Ignition Switch START (RELEASE AFTER ENGINE STARTS)

• CAUTION •

Limit cranking to intervals of 10 seconds with a 30-second cooling period between cranks. This will improve battery and contactor life.

- 12. Mixture SMOOTHLY ADVANCE TO RICH (AFTER ENGINE STARTS)
- 13. Oil Pressure CHECK
- 14. Power Lever..... RETARD (MAINTAIN 1000 RPM)
- 15. Fuel Pump OFF
- 16. ALT 1 and ALT 2 Switches ON
- 17. AVIONICS Switch ON
- 18. Engine Parameters MONITOR
- 19. External Power (If applicable) DISCONNECT
- 20. Amp Meter/Indication CHECK
- 21. Strobe Lights ON

Hot Weather Operation

Avoid prolonged engine operation on the ground. Fuel Pump must be ON for engine start and takeoff, and should be ON during climb for vapor suppression which could occur under hot ambient conditions or after extended idle.

Ground Operation of Air Conditioning System (Optional)

• NOTE •

To facilitate faster cabin cooling, prior to engine start leave the cabin doors open for a short time to allow hot air to escape cabin.

1. Control Panel.....SELECT DESIRED MODE AND TEMPERATURE
2. Voltage..... MONITOR

• NOTE •

Decrease electrical load if battery discharge is noted.

3. Annunciator Lights..... CHECK
 - a) Verify ALT 1 caution light out and positive amps indication.
4. Engine Parameters CHECK

Extended Ground Operation

For airplanes that experience prolonged engine operation on the ground, the following procedure is recommended to reduce potential for spark plug lead fouling and lead build-up on engine valve guides.

1. Set throttle to 1200 RPM.
2. Lean the mixture for maximum RPM.
3. Reduce throttle to RPM for continued ground operations (800 - 1000 RPM is recommended).

• WARNING •

Fuel flow at full throttle should be at the top of the green arc on the fuel flow gauge.

• NOTE •

If further ground operations will be required after the [Before Takeoff](#) Checklist is completed, lean the mixture again (as described above) until ready for the [Takeoff](#) Checklist.

Lead Reduction Before Shut Down

If required, complete the following procedure before shutdown to reduce potential for lead build-up in the combustion chamber, spark plugs, and engine oil.

• CAUTION •

The airplane must be stationary before the following procedure is completed.

1. Maintain throttle between 1000 and 1200 RPM until operating temperature has stabilized.
2. Increase throttle to 1800 RPM for 15 - 20 seconds.
3. Reduce throttle back to between 1000 and 1200 RPM and shut down immediately using mixture control.

Noise Characteristics/Abatement

The certificated noise levels for the aircraft established in accordance with CFR 36 Appendix G are:

Configuration	Actual	Maximum Allowable
Hartzell 3-blade Propeller, HC-E3YR-1RF/F7392S-1, Metal (Standard)	82.9 dB(A)	88.0 dB(A)
Hartzell 3-blade Propeller, 3C1-R919A1/76C03-2, Composite (Optional)	81.7 dB(A)	88.0 dB(A)

No determination has been made by the Federal Aviation Administration that the noise levels of this airplane are or should be acceptable or unacceptable for operation at, into, or out of, any airport. The above noise levels were established at 3150 pounds takeoff weight and 2700 RPM.

Recently, increased emphasis on improving environmental quality requires all pilots to minimize the effect of airplane noise on the general public. The following suggested procedures minimize environmental noise when operating the aircraft.

• NOTE •

Do not follow these noise abatement procedures where they conflict with Air Traffic Control clearances or instructions, weather considerations, or wherever they would reduce safety.

1. When operating VFR over noise-sensitive areas, such as outdoor events, parks, and recreational areas, fly not less than 2000 feet above the surface even though flight at a lower level may be allowed.
2. For departure from or approach to an airport, avoid prolonged flight at low altitude near noise-sensitive areas.

Fuel Conservation

Minimum fuel use at cruise will be achieved using the best economy power setting described under cruise.

Intentionally Left Blank

Section 5: Performance Data

Table of Contents

Introduction.....	3
Standard Charts	3
Associated Conditions Affecting Performance	3
Demonstrated Operating Temperature	3
Temperature Conversion.....	4
OAT for International Standard Atmosphere (ISA) Condition.....	5
Pressure Conversion - Inches of Mercury to Millibars	6
Fuel Quantity Conversion - U.S. Gallons to Liters	7
Weight Conversion - Pounds to Kilograms.....	8
Distance Conversion: Feet to Meters	9
Length Conversion: Inches to Centimeters	10
Airspeed Calibration	11
Normal Static Source	11
Alternate Static Source.....	12
Altitude Correction	13
Normal Static Source: Primary Flight Display.....	13
Normal Static Source: Standby Altimeter	14
Alternate Static Source: Primary Flight Display.....	15
Alternate Static Source: Standby Altimeter	16
Stall Speeds	17
Wind Components.....	18
Takeoff Distance	19
Takeoff Distance: 3150 lb (1429 kg)	20
Takeoff Distance: 2600 lb (1179 kg)	21
Takeoff Climb Gradient	22
Takeoff Rate of Climb.....	24
Enroute Climb.....	26
Enroute Climb Gradient.....	26
Enroute Rate Of Climb	28
Enroute Rate of Climb Vs Density Altitude.....	30
Time, Fuel, & Distance to Climb	31
Cruise Performance	32
Range / Endurance Profile	34
Balked Landing.....	36
Balked Landing Climb Gradient.....	36
Balked Landing Rate of Climb	38

Landing Distance.....	39
Landing Distance Table - Flaps 100%.....	40
Landing Distance Table - Flaps 50%.....	41
Landing Distance Table - Flaps 0%.....	42

Introduction

Performance data in this section are presented for operational planning so that you will know what performance to expect from the airplane under various ambient and field conditions. Performance data are presented for takeoff, climb, and cruise (including range & endurance).

All data based on published normal procedures.

Standard Charts

Associated Conditions Affecting Performance

Computed performance data in this section are based upon data derived from actual flight testing with the airplane and engine in good condition and using average piloting techniques. Unless specifically noted in the “Conditions” notes presented with each table, ambient conditions are for a standard day. Flap position as well as thrust setting technique is similarly noted with each table.

The charts in this section provide data over temperature ranges as specified on the chart. If ambient temperature is below the chart value, use the lowest temperature shown to compute performance. This will result in more conservative performance calculations. If ambient temperature is above the chart value, use caution as performance degrades rapidly at higher temperatures.

Serials w/ optional Air Conditioning System: Brake Horsepower is reduced by approximately 6 BHP.

RELATED LINKS:

[Refer to “Table 2: Meteorological Terminology” in Section 1: General.](#)

Demonstrated Operating Temperature

Satisfactory engine cooling has been demonstrated for this airplane with an Outside Air Temperature (OAT) 41 °F (23 °C) above standard. The value given is not considered an operating limitation. |

RELATED LINKS:

Refer to [Section 2: Limitations, "Powerplant Limitations"](#) for operating limitations.

Temperature Conversion

Temp to Convert °C or °F			Temp to Convert °C or °F			Temp to Convert °C or °F		
°C	<>	°F	°C	<>	°F	°C	<>	°F
-50	-58	-72	-17	2	36	17	62	144
-49	-56	-69	-16	4	39	18	64	147
-48	-54	-65	-14	6	43	19	66	151
-47	-52	-62	-13	8	46	20	68	154
-46	-50	-58	-12	10	50	21	70	158
-44	-48	-54	-11	12	54	22	72	162
-43	-46	-51	-10	14	57	23	74	165
-42	-44	-47	-9	16	61	24	76	169
-41	-42	-44	-8	18	64	26	78	172
-40	-40	-40	-7	20	68	27	80	176
-39	-38	-36	-6	22	72	28	82	180
-38	-36	-33	-4	24	75	29	84	183
-37	-34	-29	-3	26	79	30	86	187
-36	-32	-26	-2	28	82	31	88	190
-34	-30	-22	-1	30	86	32	90	194
-33	-28	-18	0	32	90	33	92	198
-32	-26	-15	1	34	93	34	94	201
-31	-24	-11	2	36	97	36	96	205
-30	-22	-8	3	38	100	37	98	208
-29	-20	-4	4	40	104	38	100	212
-28	-18	0	6	42	108	39	102	216
-27	-16	3	7	44	111	40	104	219
-26	-14	7	8	46	115	41	106	223
-24	-12	10	9	48	118	42	108	226
-23	-10	14	10	50	122	43	110	230
-22	-8	18	11	52	126	44	112	234
-21	-6	21	12	54	129	46	114	237
-20	-4	25	13	56	133	47	116	241
-19	-2	28	14	58	136	48	118	244
-18	0	32	16	60	140	49	120	248

OAT for International Standard Atmosphere (ISA) Condition

Press Alt FT	ISA -30 °C		ISA -15 °C		ISA		ISA +15 °C		ISA +30 °C	
	°C	°F	°C	°F	°C	°F	°C	°F	°C	°F
SL	-15	5	0	32	15	59	30	86	45	113
1000	-17	1	-2	28	13	55	28	82	43	109
2000	-19	-2	-4	25	11	52	26	79	41	106
3000	-21	-6	-6	21	9	48	24	75	39	102
4000	-23	-9	-8	18	7	45	22	72	37	99
5000	-25	-13	-10	14	5	41	20	68	35	95
6000	-27	-17	-12	10	3	37	18	64	33	91
7000	-29	-20	-14	7	1	34	16	61	31	88
8000	-31	-24	-16	3	-1	30	14	57	29	84
9000	-33	-27	-18	0	-3	27	12	54	27	81
10,000	-35	-31	-20	-4	-5	23	10	50	25	77
11,000	-37	-35	-22	-8	-7	19	8	46	23	73
12,000	-39	-38	-24	-11	-9	16	6	43	21	70
13,000	-41	-42	-26	-15	-11	12	4	39	19	66
14,000	-43	-45	-28	-18	-13	9	2	36	17	63
15,000	-45	-49	-30	-22	-15	5	0	32	15	59
16,000	-47	-53	-32	-26	-17	1	-2	28	13	55
17,000	-49	-56	-34	-29	-19	-2	-4	25	11	52
17,500	-50	-58	-35	-31	-20	-4	-5	23	10	50

Pressure Conversion - Inches of Mercury to Millibars

Inches Of Mercury	Millibars
28.0	948
28.1	951
28.2	955
28.3	958
28.4	962
28.5	965
28.6	968
28.7	972
28.8	975
28.9	979
29.0	982
29.1	985
29.2	989
29.3	992
29.4	995
29.5	999

Inches Of Mercury	Millibars
29.6	1002
29.7	1006
29.8	1009
29.9	1012
30.0	1016
30.1	1019
30.2	1023
30.3	1026
30.4	1029
30.5	1033
30.6	1036
30.7	1040
30.8	1043
30.9	1046
31.0	1050

Fuel Quantity Conversion - U.S. Gallons to Liters

• NOTE •

Fuel mass provided for reference assuming nominal 6.0 lb/gallon
at 59 °F (15 °C).

U.S. Gallons (Liters)	Lb (Kg)
10 (37.9)	60 (27.2)
15 (56.8)	90 (40.8)
20 (75.7)	120 (54.4)
25 (94.6)	150 (68.0)
28 (106.0)	168 (76.2)
30 (113.6)	180 (81.6)

U.S. Gallons (Liters)	Lb (Kg)
35 (132.5)	210 (95.3)
40 (151.4)	240 (108.9)
45 (170.3)	270 (122.5)
50 (189.3)	300 (136.1)
55 (208.2)	330 (150.0)
56 (212.0)	336 (152.4)

Weight Conversion - Pounds to Kilograms

Pounds	Kilograms
2000	907.2
2100	952.5
2200	998.0
2300	1043.3
2400	1088.6
2500	1134.0
2600	1179.3

Pounds	Kilograms
2700	1224.7
2800	1270.1
2900	1315.4
3000	1360.1
3100	1406.1
3150	1428.8

Distance Conversion: Feet to Meters

Feet	Meters
10	3
20	6
30	9
40	12
50	15
60	18
70	21
80	24
90	27
100	30
200	61
300	91
400	122
500	152

Feet	Meters
600	183
700	213
800	244
900	274
1000	305
2000	610
3000	914
4000	1219
5000	1524
6000	1829
7000	2134
8000	2438
9000	2743
10,000	3048

Length Conversion: Inches to Centimeters

Inches	Centimeters
1	2.54
2	5.08
3	7.62
4	10.16
5	12.70
6	15.24
7	17.78
8	20.32
9	22.86
10	25.40
11	27.94
12	30.48

Inches	Centimeters
20	50.8
30	76.2
40	101.6
50	127
60	142.4
70	177.8
80	203.2
90	228.6
100	254
150	381
200	508
250	635

Airspeed Calibration

Normal Static Source

Conditions:

- Power for level flight or maximum continuous, whichever is less.

• NOTE •

Indicated airspeed values assume zero instrument error.

KIAS	KCAS		
	Flaps 0%	Flaps 50%	Flaps 100%
60	57	56	57
70	68	68	70
80	79	80	80
90	89	91	89
100	100	101	99
110	111	111	111
120	121	121	
130	132	131	
140	142	140	
150	152	149	
160	163		
170	173		
180	183		
190	193		
200	203		

Alternate Static Source

Conditions:

- Power for level flight or maximum continuous, whichever is less.
- Heater, Defroster & VentsON

• NOTE •

Indicated airspeed values assume zero instrument error.

KIAS	KCAS		
	Flaps 0%	Flaps 50%	Flaps 100%
60	61	58	54
70	68	66	63
80	77	74	72
90	85	83	82
100	94	92	92
110	103	102	101
120	112	112	110
130	121	122	
140	131	132	
150	141	144	
160	150	155	
170	160		
180	170		
190	179		
200	189		
210	198		

Altitude Correction

Normal Static Source: Primary Flight Display

Conditions:

- Power for level flight or maximum continuous, whichever is less.
- 3150 LB

• NOTE •

Add correction to desired altitude to obtain indicated altitude to fly.

Indicated airspeed values assume zero instrument error.
KIAS: Knots Indicated Airspeed.

Flaps	Density Alt	CORRECTION TO BE ADDED (ft)										
		Normal Static Source - KIAS										
		60	70	80	90	100	120	140	160	180	200	
0%	S.L.		0	0	0	0	0	0	0	0	0	0
	5000		0	0	0	0	0	0	0	0	0	0
	10000		0	0	0	0	0	0	0	0	0	0
	15000		0	0	0	0	0	0	0	0	0	0
50%	S.L.		-1	-6	-10	-11	-3	26	81			
	5000		-2	-7	-12	-13	-4	30	94			
	10000		-2	-8	-13	-15	-4	35	110			
100%	S.L.	28	-13	-8	-9	-6	78					
	5000	33	-15	-9	-10	-7	90					
	10000	38	-18	-11	-12	-8	105					

Normal Static Source: Standby Altimeter

Conditions:

- Power for level flight or maximum continuous, whichever is less.
- 3150 LB

• NOTE •

Add correction to desired altitude to obtain indicated altitude to fly.

Indicated airspeed values assume zero instrument error.

KIAS: Knots Indicated Airspeed.

Flaps	Density Alt	CORRECTION TO BE ADDED (ft)									
		Normal Static Source - KIAS									
		60	70	80	90	100	120	140	160	180	200
0%	S.L.		12	9	5	0	-11	-24	-38	-50	-61
	5000		14	10	6	0	-13	-28	-44	-58	-71
	10000		16	12	7	0	-16	-33	-51	-68	-82
	15000		19	14	8	0	-18	-39	-60	-80	-97
50%	S.L.		11	3	-5	-11	-15	1	43		
	5000		12	3	-6	-13	-17	1	50		
	10000		15	4	-7	-15	-20	1	59		
100%	S.L.	14	-1	1	-4	-6	66				
	5000	16	-1	1	-5	-7	77				
	10000	19	-1	1	-5	-8	90				

Alternate Static Source: Primary Flight Display

Conditions:

- Power for level flight or maximum continuous, whichever is less.
- Heater, Defroster & Vents..... ON

• NOTE •

Add correction to desired altitude to obtain indicated altitude to fly.

Indicated airspeed values assume zero instrument error.

KIAS: Knots Indicated Airspeed.

Flaps	Density Alt	CORRECTION TO BE ADDED (ft)									
		Alternate Static Source - KIAS									
		60	70	80	90	100	120	140	160	180	200
0%	S.L.		-2	15	33	52	92	131	170	209	253
	5000		-3	17	39	61	107	152	197	243	294
	10000		-3	20	45	71	125	178	230	283	343
	15000		-4	23	53	83	146	209	270	332	403
50%	S.L.		12	29	47	65	96	114	109		
	5000		14	34	55	75	112	133	127		
	10000		17	40	64	88	130	155	148		
100%	S.L.	43	29	42	54	66	114				
	5000	49	34	49	62	77	132				
	10000	58	40	57	72	90	154				

Alternate Static Source: Standby Altimeter

Conditions:

- Power for level flight or maximum continuous, whichever is less.
- Heater, Defroster & VentsON

• NOTE •

Add correction to desired altitude to obtain indicated altitude to fly.

Indicated airspeed values assume zero instrument error.

KIAS: Knots Indicated Airspeed.

Flaps	Density Alt	CORRECTION TO BE ADDED (ft)									
		Alternate Static Source - KIAS									
		60	70	80	90	100	120	140	160	180	200
0%	S.L.		10	24	38	53	81	107	132	159	192
	5000		11	28	44	61	94	124	153	184	223
	10000		13	32	52	71	109	145	179	215	261
	15000		15	38	61	84	128	170	210	252	306
50%	S.L.		24	38	52	65	85	90	71		
	5000		28	44	60	75	98	104	83		
	10000		33	52	70	88	115	122	96		
100%	S.L.	29	41	51	58	67	102				
	5000	33	48	59	68	77	119				
	10000	39	56	69	79	90	139				

Stall Speeds

Conditions:

- Weight..... 3150 LB
- CG..... Noted
- Power..... Idle
- Bank Angle Noted

• NOTE •

Altitude loss during wings level stall may be 250 ft or more.

KIAS values may not be accurate at stall.

Bank Angle Deg	STALL SPEEDS					
	Flaps 0% Full Up		Flaps 50%		Flaps 100% Full Down	
	KIAS	KCAS	KIAS	KCAS	KIAS	KCAS
3150 lb - Most FWD C.G.						
0	71	69	67	64	62	60
15	72	70	68	66	63	61
30	76	74	71	69	65	64
45	83	82	77	77	71	71
60	98	98	90	91	85	85
3150 lb - Most AFT C.G.						
0	71	69	64	61	60	57
15	72	70	65	62	61	58
30	76	74	68	66	63	61
45	83	82	74	73	68	68
60	98	98	86	86	81	81

Wind Components

Example:

Runway Heading 10°
 Wind Direction 60°
 Wind Velocity 15 Knots

• NOTE •

The maximum demonstrated crosswind is 20 knots. Value not considered limiting.

Figure 5-1: Wind Components

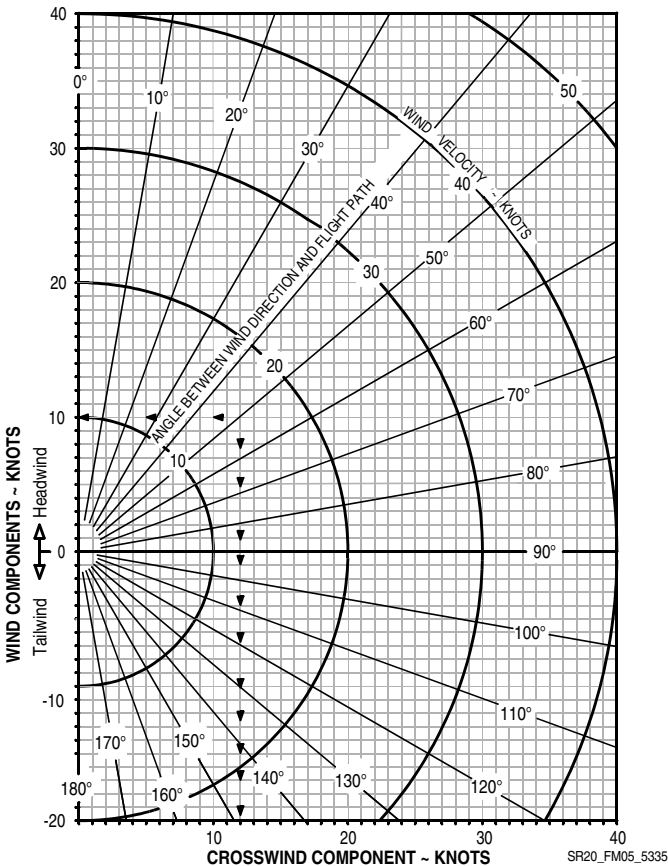

Takeoff Distance

Conditions:

- Winds Zero
- Runway..... Dry, Level, Paved
- Flaps..... 50%
- Air Conditioner OFF
- Power..... Full Throttle
- Mixture..... Set to top of GREEN ARC
Set mixture prior to brake release for short field takeoff.

The following factors are to be applied to the computed takeoff distance for the noted condition.

Headwind - Subtract 10% from computed distance per each 12 knots headwind.

Tailwind - Add 10% per each 2 knots tailwind up to 10 knots.

Grass Runway, Dry - Add 20% to ground roll distance.

Grass Runway, Wet - Add 30% to ground roll distance.

Sloped Runway - Increase table distances by 22% of the ground roll distance at Sea Level, 30% of the ground roll distance at 5000 ft, 43% of the ground roll distance at 10,000 ft per each 1% of upslope. Decrease table distances by 7% of the ground roll distance at Sea Level, 10% of the ground roll distance at 5000 ft, and 14% of the ground roll distance at 10,000 ft per each 1% of downslope.

• CAUTION •

The above corrections for runway slope are required to be included herein. These corrections should be used with caution since published runway slope data is usually the net slope from one end of the runway to the other. Many runways will have portions of their length at greater or lesser slopes than the published slope, lengthening (or shortening) takeoff ground roll estimated from the table.

- If brakes are not held while applying power, distances apply from point where full throttle and mixture setting is complete.
- For operation in outside air temperatures colder than this table provides, use coldest data shown.
- For operation in outside air temperatures warmer than this table provides, use caution.
- Aircraft with optional Air Conditioning System: Add 300 ft to ground roll distance and 400 ft to distance over 50 ft obstacle if Air Conditioner is ON during takeoff.

Takeoff Distance: 3150 lb (1429 kg)

<p>Weight: 3150 lb (1429 kg) Approximate Speed at Liftoff: 75 KIAS Speed over 50 ft Obstacle: 81 KIAS Flaps: 50% Power: Full Throttle Mixture: Set to top of GREEN ARC Runway: Dry, Level, Paved</p>	<p>Headwind: Subtract 10% per each 12 knots headwind. Tailwind: Add 10% per each 2 knots tailwind up to 10 knots. Runway Slope: Refer to list of factors. Dry Grass: Add 20% to ground roll. Wet Grass: Add 30% to ground roll. Air Conditioner: Add 300 ft to ground roll and 400 ft to distance over 50 ft obstacle if Air Conditioner is ON during takeoff.</p>
--	---

Press Alt FT	Distance FT	TEMPERATURE ~°C						
		0	10	20	30	40	50	ISA
SL	Gnd Roll	1503	1623	1748	1877	2011	2150	1685
	Total	2273	2443	2618	2799	2986	3179	2530
1000	Gnd Roll	1653	1784	1921	2063	2210	2363	1825
	Total	2491	2675	2867	3065	3270	3482	2732
2000	Gnd Roll	1818	1962	2113	2269	2431	2599	1978
	Total	2730	2932	3142	3359	3584	3817	2953
3000	Gnd Roll	2002	2161	2326	2498	2676	2862	2145
	Total	2995	3217	3447	3686	3932	4187	3195
4000	Gnd Roll	2206	2381	2563	2753	2950	3154	2329
	Total	3288	3532	3785	4048	4319	4599	3460
5000	Gnd Roll	2433	2626	2827	3037	3254	3479	2530
	Total	3614	3883	4161	4449	4747	5055	3749
6000	Gnd Roll	2687	2900	3122	3353	3592	3841	2752
	Total	3976	4272	4578	4895	5224	5563	4066
7000	Gnd Roll	2969	3205	3450	3705	3970	4245	2995
	Total	4379	4705	5042	5392	5754	6127	4414
8000	Gnd Roll	3322	3586	3861	4146	4442	4750	3300
	Total	4883	5246	5622	6013	6416	6833	4851
9000	Gnd Roll	3752	4050	4360	4682	5017	5364	3669
	Total	5495	5904	6328	6767	7221	7691	5380
10,000	Gnd Roll	4240	4577	4927	5291	5670	6062	4082
	Total	6188	6649	7127	7621	8133	8663	5970

Takeoff Distance: 2600 lb (1179 kg)

<p>Weight: 2600 lb (1179 kg) Approximate Speed at Liftoff: 69 KIAS Speed over 50 ft Obstacle: 75 KIAS Flaps: 50% Power: Full Throttle Mixture: Set to top of GREEN ARC Runway: Dry, Level, Paved</p>	<p>Headwind: Subtract 10% per each 12 knots headwind. Tailwind: Add 10% per each 2 knots tailwind up to 10 knots. Runway Slope: Refer to list of factors. Dry Grass: Add 20% to ground roll. Wet Grass: Add 30% to ground roll. Air Conditioner: Add 300 ft to ground roll and 400 ft to distance over 50 ft obstacle if Air Conditioner is ON during takeoff.</p>
--	---

Press Alt FT	Distance FT	TEMPERATURE ~°C						
		0	10	20	30	40	50	ISA
SL	Gnd Roll	913	986	1061	1140	1221	1305	1023
	Total	1408	1513	1621	1732	1848	1967	1566
1000	Gnd Roll	1004	1083	1166	1252	1342	1435	1108
	Total	1542	1656	1775	1897	2024	2154	1692
2000	Gnd Roll	1104	1192	1283	1378	1476	1578	1201
	Total	1690	1815	1945	2079	2218	2361	1828
3000	Gnd Roll	1215	1312	1412	1517	1625	1738	1303
	Total	1854	1991	2133	2281	2433	2590	1978
4000	Gnd Roll	1339	1446	1556	1671	1791	1915	1414
	Total	2036	2186	2342	2504	2672	2844	2141
5000	Gnd Roll	1477	1595	1717	1844	1975	2112	1536
	Total	2237	2403	2574	2752	2936	3126	2320
6000	Gnd Roll	1631	1761	1896	2036	2181	2332	1671
	Total	2461	2643	2832	3028	3230	3440	2516
7000	Gnd Roll	1803	1946	2095	2250	2411	2577	1818
	Total	2710	2911	3119	3335	3558	3788	2731
8000	Gnd Roll	2017	2178	2344	2518	2697	2884	2004
	Total	3021	3245	3477	3718	3967	4224	3001
9000	Gnd Roll	2278	2459	2647	2843	3046	3257	2228
	Total	3399	3651	3913	4184	4464	4754	3328
10,000	Gnd Roll	2575	2779	2992	3213	3442	3681	2478
	Total	3827	4112	4406	4711	5027	5353	3693

Takeoff Climb Gradient

Conditions:

- Power Full Throttle
- Mixture Set to top of GREEN ARC
- Flaps 50%
- Airspeed Best Rate of Climb

• NOTE •

Climb Gradients shown are the gain in altitude for the horizontal distance traversed expressed as Feet per Nautical Mile.

Fuel flow must be set to the top of green arc for all takeoffs and climbs.

Cruise climbs or short duration climbs are permissible at best power as long as altitudes and temperatures remain within those specified in the table.

For operation in air colder than this table provides, use coldest data shown. For operation in air warmer than this table provides, use caution.

Weight LB	Press Alt FT	Climb Speed KIAS	CLIMB GRADIENT - Feet per Nautical Mile					
			TEMPERATURE ~°C					
			-20	0	20	40	50	ISA
3150	SL	88	624	568	517	469	446	529
	2000	87	531	479	431	386	365	452
	4000	86	442	394	349	307	288	377
	6000	86	357	312	270	232	213	305
	8000	85	276	234	196	160	143	236
	10000	84	199	160	124	91	75	169

Weight LB	Press Alt FT	Climb Speed KIAS	CLIMB GRADIENT - Feet per Nautical Mile					
			TEMPERATURE ~°C					
			-20	0	20	40	50	ISA
2600	SL	88	843	775	712	653	626	727
	2000	87	731	668	609	554	529	635
	4000	86	624	565	511	460	436	546
	6000	86	523	468	418	371	348	460
	8000	85	426	376	329	285	264	378
	10000	84	334	288	244	204	185	299

Takeoff Rate of Climb

Conditions:

- Power Full Throttle
- Mixture Set to top of GREEN ARC
- Flaps 50%
- Airspeed Best Rate of Climb

• NOTE •

Rate-of-Climb values shown are change in altitude for unit time expended expressed in Feet per Minute.

Fuel flow must be set to the top of green arc for all takeoffs and climbs.

Cruise climbs or short duration climbs are permissible at best power as long as altitudes and temperatures remain within those specified in the table.

For operation in air colder than this table provides, use coldest data shown. For operation in air warmer than this table provides, use caution.

Aircraft with optional Air Conditioning System: Maximum rate of climb performance is reduced by approximately 75 feet per minute. For maximum climb performance the Air Conditioner should be OFF.

Weight LB	Press Alt FT	Climb Speed KIAS	RATE OF CLIMB - Feet per Minute					
			TEMPERATURE ~°C					
			-20	0	20	40	50	ISA
3150	SL	88	862	816	769	721	698	781
	2000	87	752	706	658	610	586	680
	4000	86	643	595	547	498	474	578
	6000	86	533	485	435	386	361	477
	8000	85	423	374	323	273	248	376
	10000	84	313	262	211	160	134	275

Weight LB	Press Alt FT	Climb Speed KIAS	RATE OF CLIMB - Feet per Minute					
			TEMPERATURE ~°C					
			-20	0	20	40	50	ISA
2600	SL	88	1159	1109	1056	1003	976	1069
	2000	87	1033	981	928	874	847	952
	4000	86	906	854	800	745	718	835
	6000	86	780	726	671	616	589	718
	8000	85	654	599	543	487	459	602
	10000	84	527	471	415	358	329	486

Enroute Climb

Enroute Climb Gradient

Conditions:

- Power Full Throttle
- Mixture..... Set to top of GREEN ARC
- Flaps..... 0% (UP)
- Airspeed Best Rate of Climb

• NOTE •

Climb Gradients shown are the gain in altitude for the horizontal distance traversed expressed as Feet per Nautical Mile.

Cruise climbs or short duration climbs are permissible at best power as long as altitudes and temperatures remain within those specified in the table.

Fuel flow must be set to the top of green arc for all climbs.

For operation in air colder than this table provides, use coldest data shown. For operation in air warmer than this table provides, use caution.

Weight	Press Alt	Climb Speed	CLIMB GRADIENT - Feet per Nautical Mile					
			TEMPERATURE ~°C					
LB	FT	KIAS	-20	0	20	40	50	ISA
3150	SL	97	646	583	526	473	448	540
	2000	96	547	488	435	385	362	458
	4000	95	453	398	348	302	281	380
	6000	94	363	312	266	223	203	305
	8000	94	278	231	188	148	129	233
	10000	93	198	154	114	77	59	164
	12000	92	122	81	43	9	-7	98
14000	91	49	11	-24	-56	-71	35	

Weight LB	Press Alt FT	Climb Speed KIAS	CLIMB GRADIENT - Feet per Nautical Mile					
			TEMPERATURE ~°C					
			-20	0	20	40	50	ISA
2600	SL	93	857	780	710	645	615	727
	2000	92	737	666	600	540	512	629
	4000	92	623	557	496	440	414	535
	6000	91	516	454	397	345	321	445
	8000	90	414	356	304	255	233	359
	10000	89	317	264	215	170	149	276
	12000	88	226	176	131	89	70	198
	14000	88	140	93	51	12	-6	123

Enroute Rate Of Climb

Conditions:

- Power Full Throttle
- Mixture Set to top of GREEN ARC
- Flaps 0% (UP)
- Airspeed Best Rate of Climb

• NOTE •

Rate-of-Climb values shown are change in altitude in feet per unit time expressed in Feet per Minute.

Cruise climbs or short duration climbs are permissible at best power as long as altitudes and temperatures remain within those specified in the table.

For operation in air colder than this table provides, use coldest data shown.

For operation in air warmer than this table provides, use caution.

Fuel flow must be set to the top of green arc for all climbs.

Aircraft with optional Air Conditioning System: Maximum rate of climb performance is reduced by approximately 75 feet per minute if system is ON. For maximum climb performance, the Air Conditioner should be OFF.

Weight	Press Alt	Climb Speed	RATE OF CLIMB - Feet per Minute					
			TEMPERATURE ~°C					
LB	FT	KIAS	-20	0	20	40	50	ISA
3150	SL	97	968	908	849	789	760	864
	2000	96	843	783	723	663	633	750
	4000	95	719	657	596	535	505	636
	6000	94	594	532	469	407	376	522
	8000	94	469	405	341	278	247	408
	10000	93	344	278	212	148	116	294
	12000	92	218	150	83	17	-15	180
	14000	91	91	21	-48	-115	-148	66

Weight LB	Press Alt FT	Climb Speed KIAS	RATE OF CLIMB - Feet per Minute					
			TEMPERATURE ~°C					
			-20	0	20	40	50	ISA
2600	SL	97	1279	1211	1143	1075	1041	1160
	2000	96	1133	1065	995	927	893	1026
	4000	95	988	918	848	778	744	893
	6000	94	842	771	699	629	594	760
	8000	94	697	624	551	479	444	627
	10000	93	551	476	402	329	293	494
	12000	92	405	328	252	177	141	362
	14000	91	258	179	101	26	-12	230

Enroute Rate of Climb Vs Density Altitude

Conditions:

- Power Full Throttle
- Mixture Set to top of GREEN ARC
- Flaps 0% (UP)
- Airspeed Best Rate of Climb

Figure 5-2: Enroute Rate of Climb Vs Density Altitude

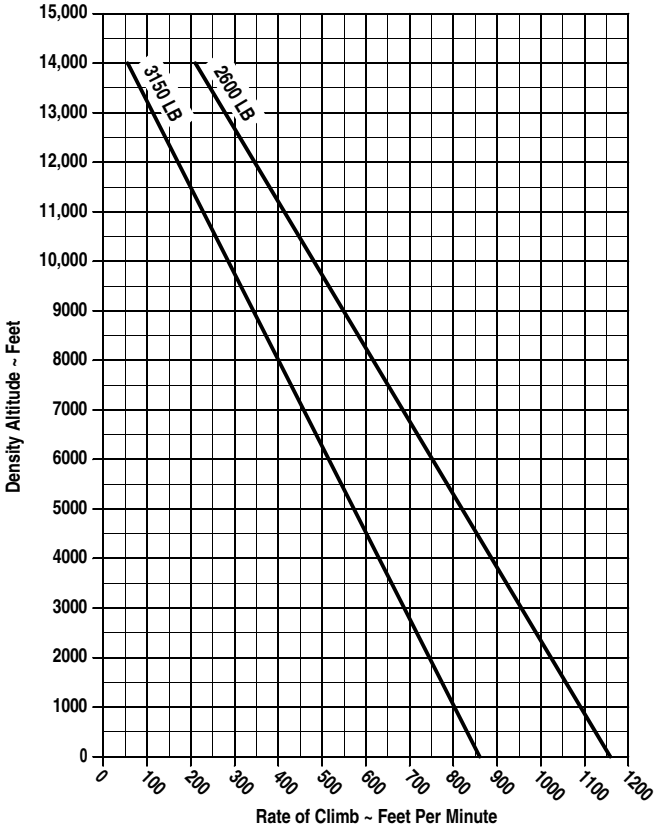

SR20_FM05_5418

Time, Fuel, & Distance to Climb

Conditions:

- Power..... Full Throttle
- Mixture..... Set to top of GREEN ARC
- Fuel Density..... 6.0 LB/GAL
- Weight..... 3150 LB
- Winds..... Zero
- Climb Airspeed..... Noted

• NOTE •

Taxi Fuel - Add 1.5 gallon for start, taxi, and takeoff.

Temperature - Add 10% to computed values per each 10 °C above standard.

Fuel flow must be set to the top of green arc for all takeoffs and climbs.

Cruise climbs or short duration climbs are permissible at best power as long as altitudes and temperatures remain within those specified in the table.

Press Alt FT	OAT (ISA) °C	Climb Speed KIAS	Rate Of Climb FPM	TIME, FUEL, DISTANCE ~ From Sea Level		
				Time Minutes	Fuel U.S. Gal	Distance NM
SL	15	97	864	0.0	0.0	0
1000	13	96	807	1.2	0.4	2
2000	11	96	750	2.6	0.8	4
3000	9	95	693	4.0	1.3	7
4000	7	95	636	5.6	1.7	9
5000	5	95	579	7.3	2.3	12
6000	3	94	522	9.2	2.8	15
7000	1	94	465	11.4	3.4	19
8000	-1	94	408	13.8	4.1	23
9000	-3	93	351	16.7	4.8	28
10000	-5	93	294	20.1	5.7	35
11000	-7	92	237	24.3	6.8	42
12000	-9	92	180	29.9	8.2	52
13000	-11	92	123	38.0	10.1	67
14000	-13	91	66	53.2	13.6	96

Cruise Performance

Conditions:

- Mixture Target Fuel Flow*
- Weight 2600 LB
- Winds Zero
- Shaded Cells: Cruise Pwr above 85% not recommended.

*For power settings greater than 75% power, Best Power.

• NOTE •

Subtract 10 KTAS if nose wheel pant and fairing removed. Lower KTAS by 10% if nose and main wheel pants and fairings are removed.

Aircraft with optional Air Conditioning System: Cruise performance is reduced by 2 knots. For maximum cruise performance, the Air Conditioner should be OFF.

Aircraft with optional Enhanced Vision System: Cruise performance is reduced by up to 1 knot.

Press Alt FT	RPM	MAP	ISA -30 °C			ISA			ISA +30 °C		
			PWR	KTAS	GPH	PWR	KTAS	GPH	PWR	KTAS	GPH
2000	2700	27.1	94%	151	16.5	90%	156	15.8	85%	158	15.2
	2500	27.1	86%	148	14.9	82%	151	14.2	78%	153	13.7
	2500	26.0	81%	145	14.2	77%	148	13.6	73%	150	11.5
	2500	24.9	77%	142	13.5	73%	144	12.3	69%	146	10.9
	2500	23.8	72%	139	13.3	68%	140	11.6	65%	142	10.3
	2500	22.7	67%	135	12.5	64%	136	10.9	61%	138	9.7
	2500	21.6	62%	130	11.7	59%	132	10.3	56%	132	9.1
	2500	20.5	58%	126	11.0	55%	127	9.6	52%	127	8.5
	2500	19.4	53%	121	10.2	50%	121	9.0	48%	121	8.0
4000	2700	25.2	88%	152	15.6	84%	155	14.9	80%	157	14.4
	2500	25.2	80%	147	14.1	76%	150	13.4	73%	152	11.2
	2500	24.1	76%	144	13.4	72%	146	12.0	68%	148	10.6
	2500	23.0	71%	140	13.0	67%	142	11.3	64%	144	10.0
	2500	21.9	66%	136	12.2	63%	138	10.6	60%	139	9.4
	2500	20.8	61%	132	11.4	58%	133	9.9	55%	134	8.8
	2500	19.7	57%	127	10.6	54%	128	9.3	51%	128	8.2
	2500	18.6	52%	121	9.9	49%	122	8.6	47%	122	7.7
	2500	17.5	47%	115	9.1	45%	115	8.0	42%	115	7.1

Press Alt FT	RPM	MAP	ISA -30 °C			ISA			ISA +30 °C		
			PWR	KTAS	GPH	PWR	KTAS	GPH	PWR	KTAS	GPH
6000	2700	23.4	82%	151	14.7	78%	154	14.1	74%	156	11.4
	2500	23.4	75%	146	13.5	71%	148	11.7	68%	150	10.4
	2500	22.3	70%	142	12.7	66%	144	11.0	63%	145	9.7
	2500	21.2	65%	138	11.9	62%	140	10.3	59%	141	9.1
	2500	20.1	60%	133	11.1	57%	135	9.7	55%	136	8.6
	2500	19.0	56%	128	10.3	53%	129	9.0	50%	129	8.0
	2500	17.9	51%	123	9.6	48%	123	8.4	46%	123	7.4
	2500	16.8	46%	116	8.8	44%	116	7.7	42%	115	6.9
8000	2700	21.6	76%	150	13.9	72%	152	11.9	69%	154	10.5
	2500	21.6	70%	144	12.5	66%	146	10.8	63%	148	9.5
	2500	20.5	65%	140	11.6	61%	142	10.1	58%	143	8.9
	2500	19.4	60%	135	10.9	57%	137	9.4	54%	137	8.4
	2500	18.3	55%	130	10.1	52%	131	8.8	50%	131	7.8
	2500	17.2	50%	124	9.3	48%	124	8.1	45%	124	7.2
	2500	16.1	45%	117	8.6	43%	117	7.5	41%	116	6.7
10000	2700	20.0	71%	148	12.7	67%	150	11.0	64%	151	9.7
	2500	20.0	65%	142	11.5	61%	144	10.0	58%	145	8.8
	2500	18.9	60%	138	10.7	56%	139	9.3	54%	139	8.2
	2500	17.8	55%	132	9.9	52%	133	8.6	49%	133	7.6
	2500	16.7	50%	126	9.1	47%	126	8.0	45%	126	7.1
	2500	15.6	45%	119	8.4	43%	118	7.3	41%	117	6.5
12000	2700	18.5	66%	146	11.7	62%	147	10.1	59%	148	8.9
	2500	18.5	60%	140	10.6	57%	141	9.2	54%	142	8.1
	2500	17.4	55%	135	9.8	52%	135	8.5	49%	135	7.5
	2500	16.3	50%	128	9.0	47%	128	7.9	45%	128	6.9
	2500	15.2	45%	121	8.3	43%	120	7.2	40%	119	6.4
14000	2700	17.1	61%	143	10.8	57%	144	9.3	54%	145	8.2
	2500	17.1	55%	137	9.8	52%	138	8.5	50%	138	7.5
	2500	16.0	50%	131	9.0	48%	131	7.8	45%	130	6.9
	2500	14.9	45%	123	8.2	43%	123	7.1	41%	121	6.3

Range / Endurance Profile

Conditions:

- Weight 3000 LB
- Temperature Standard Day
- Winds Zero
- Mixture See Tables
- Total Fuel 56 Gallons

• NOTE •

Fuel Remaining For Cruise accounts for 10.1 gallons for 45 minutes IFR reserve fuel at 75% power and fuel burn for descent. Range and endurance shown includes descent to final destination at 160 KIAS and 500 fpm.

Range is decreased by 5% if nose wheel pant and fairings removed.

Range is decreased by 15% if nose and main wheel pants and fairings removed.

Aircraft with optional Air Conditioning System: Range is decreased by 1% if system in operation. For maximum range, the Air Conditioner should be OFF.

75% POWER				Mixture = Target Fuel Flow			
Press Alt	Climb Fuel	Fuel Remaining For Cruise	Airspeed	Fuel Flow	Endurance	Range	Specific Range
FT	GAL	GAL	KTAS	GPH	HOURS	NM	NM/GAL
0	0.0	47.9	144	12.3	3.9	558	11.6
2000	0.8	47.2	146	12.1	3.9	574	12.1
4000	1.7	46.4	149	12.0	3.9	588	12.5
6000	2.8	45.5					
8000	4.1	44.3					
10000	5.7	42.7					
12000	8.2	40.4					
14000	13.6	35.0					

65% POWER				Mixture = Target Fuel Flow			
Press Alt	Climb Fuel	Fuel Remaining For Cruise	Airspeed	Fuel Flow	Endurance	Range	Specific Range
FT	GAL	GAL	KTAS	GPH	HOURS	NM	NM/GAL
0	0.0	47.9	135	10.9	4.4	596	12.4
2000	0.8	47.2	138	10.7	4.4	613	12.9
4000	1.7	46.4	140	10.5	4.4	629	13.4
6000	2.8	45.5	143	10.3	4.4	643	13.8
8000	4.1	44.3	145	10.2	4.3	655	14.4
10000	5.7	42.7					
12000	8.2	40.4					
14000	13.6	35.0					

55% POWER				Mixture = Target Fuel Flow			
Press Alt	Climb Fuel	Fuel Remaining For Cruise	Airspeed	Fuel Flow	Endurance	Range	Specific Range
FT	GAL	GAL	KTAS	GPH	HOURS	NM	NM/GAL
0	0.0	47.9	125	9.5	5.1	630	13.2
2000	0.8	47.2	127	9.3	5.1	651	13.7
4000	1.7	46.4	130	9.1	5.1	670	14.2
6000	2.8	45.5	132	9.0	5.1	687	14.8
8000	4.1	44.3	135	8.8	5.0	700	15.3
10000	5.7	42.7	137	8.7	4.9	709	15.8
12000	8.2	40.4	139	8.6	4.7	709	16.3
14000	13.6	35.0					

Balked Landing

Balked Landing Climb Gradient

Conditions:

- Power Full Throttle
- Mixture Set to top of GREEN ARC
- Flaps 100% (DN)
- Airspeed Best Rate of Climb

• NOTE •

Balked Landing Climb Gradients shown are the gain in altitude for the horizontal distance traversed expressed as Feet per Nautical Mile.

For operation in air colder than this table provides, use coldest data shown.

For operation in air warmer than this table provides, use caution.

Fuel flow must be set to the top of green arc for all climbs.

This chart is required data for certification. However, significantly better performance can be achieved by climbing at Best Rate of Climb speeds shown with flaps down or following the [Balked Landing/Go-Around](#) procedure in Section 4.

Weight	Press Alt	Climb Speed	CLIMB GRADIENT - Feet per Nautical Mile					
			TEMPERATURE ~°C					
			-20	0	20	40	50	ISA
LB	FT	KIAS						
3150	SL	78	695	606	526	454	421	546
	2000	78	559	479	407	341	310	438
	4000	78	433	361	295	235	207	337
	6000	78	317	250	190	136	110	241
	8000	78	209	148	93	43	19	151
	10000	78	108	52	2	-44	-65	66

Weight LB	Press Alt FT	Climb Speed KIAS	CLIMB GRADIENT - Feet per Nautical Mile					
			TEMPERATURE ~°C					
			-20	0	20	40	50	ISA
2600	SL	78	940	831	733	644	603	756
	2000	78	773	675	586	506	469	625
	4000	78	619	530	450	377	343	501
	6000	78	477	396	323	257	226	385
	8000	78	345	271	204	144	116	275
	10000	78	223	155	94	39	13	172

Balked Landing Rate of Climb

Conditions:

- Power Full Throttle
- Mixture Set to top of GREEN ARC
- Flaps 100% (DN)
- Airspeed Noted

• NOTE •

Balked Landing Rate of Climb values shown are the full flaps change in altitude for unit time expended expressed in Feet per Minute.

Blank shaded cells in the table represent performance below the minimum balked landing climb requirements.

For operation in air colder than this table provides, use coldest data shown. For operation in air warmer than this table provides, use caution.

Fuel flow must be set to the top of green arc for all climbs.

This chart is required data for certification. However, significantly better performance can be achieved by climbing at Best Rate of Climb speeds shown with flaps down or following the [Balked Landing/Go-Around](#) procedure in Section 4.

Weight	Press Alt	Climb Speed	RATE OF CLIMB - Feet per Minute					
			TEMPERATURE ~°C					
			-20	0	20	40	50	ISA
LB	FT	KIAS						
3150	SL	78	840	763	687	613	577	706
	2000	78	703	626	551	478	442	584
	4000	78	566	490	415	342	306	463
	6000	78	430	353	278	205	169	342
	8000	78	295	217	141	67	31	221
	10000	78	159	80	3	-72	-108	99
2600	SL	78	1130	1040	953	867	825	974
	2000	78	968	879	792	708	667	831
	4000	78	806	718	632	548	507	688
	6000	78	646	558	472	387	346	545
	8000	78	487	398	311	226	184	402
	10000	78	328	237	149	63	21	259

Landing Distance

Conditions:

- Winds Zero
- Runway..... Dry, Level, Paved
- Flaps..... 100%, 50%, or 0%
- Power..... 3° Power Approach to 50 ft obstacle, then reduce power passing the estimated 50 ft point and smoothly continue power reduction to reach idle just prior to touchdown.

The following factors are to be applied to the computed takeoff distance for the noted condition.

Headwind - Subtract 10% from table distances per each 13 knots headwind.

Tailwind - Add 10% to table distances per each 2 knots tailwind up to 10 knots.

Grass Runway, Dry - Add 20% to ground roll distance.

Grass Runway, Wet - Add 60% to ground roll distance.

Sloped Runway - Increase table distances by 27% of the ground roll distance per each 1% of downslope. Decrease table distances by 9% of the ground roll distance per each 1% of upslope.

• CAUTION •

The above corrections for runway slope are required to be included herein. These corrections should be used with caution since published runway slope data is usually the net slope from one end of the runway to the other. Many runways will have portions of their length at greater or lesser slopes than the published slope, lengthening (or shortening) landing ground roll estimated from the table.

- For operation in outside air temperatures colder than this table provides, use coldest data shown.
- For operation in outside air temperatures warmer than this table provides, use caution.

Landing Distance Table - Flaps 100%

Weight: 3150 lb (1429 kg)	Headwind: Subtract 10% per each 13 knots headwind.
Speed over 50 ft Obstacle: 78 KIAS	Tailwind: Add 10% per each 2 knots tailwind up to 10 knots.
Flaps: 100%	Runway Slope: Refer to list of factors.
Power: Idle	Dry Grass: Add 20% to ground roll.
Runway: Dry, Level, Paved	Wet Grass: Add 60% to ground roll.

Press Alt FT	Distance FT	TEMPERATURE ~°C						
		0	10	20	30	40	50	ISA
SL	Gnd Roll	809	838	868	897	927	957	853
	Total	2557	2609	2663	2717	2773	2829	2636
1000	Gnd Roll	838	869	900	931	961	992	878
	Total	2610	2665	2722	2779	2838	2898	2682
2000	Gnd Roll	870	901	933	965	997	1029	905
	Total	2666	2725	2785	2846	2907	2970	2731
3000	Gnd Roll	902	935	968	1001	1034	1067	932
	Total	2726	2788	2852	2916	2981	3048	2782
4000	Gnd Roll	936	971	1005	1039	1073	1108	960
	Total	2790	2856	2923	2991	3060	3130	2837
5000	Gnd Roll	972	1007	1043	1079	1114	1150	990
	Total	2858	2928	2999	3070	3143	3217	2894
6000	Gnd Roll	1009	1046	1083	1120	1157	1194	1021
	Total	2931	3004	3079	3155	3232	3310	2954
7000	Gnd Roll	1048	1086	1125	1163	1201	1240	1052
	Total	3008	3086	3165	3245	3326	3409	3017
8000	Gnd Roll	1089	1128	1168	1208	1248	1288	1085
	Total	3091	3173	3256	3341	3427	3513	3084
9000	Gnd Roll	1131	1173	1214	1255	1297	1338	1119
	Total	3179	3265	3353	3443	3533	3625	3154
10,000	Gnd Roll	1176	1219	1262	1305	1348	1391	1155
	Total	3272	3364	3457	3551	3646	3743	3228

Landing Distance Table - Flaps 50%

Weight: 3150 lb (1429 kg)	Headwind: Subtract 10% per each 13 knots headwind.
Speed over 50 ft Obstacle: 82 KIAS	Tailwind: Add 10% per each 2 knots tailwind up to 10 knots.
Flaps: 50%	Runway Slope: Refer to list of factors.
Power: Idle	Dry Grass: Add 20% to ground roll.
Runway: Dry, Level, Paved	Wet Grass: Add 60% to ground roll.

Press Alt FT	Distance FT	TEMPERATURE ~°C						
		0	10	20	30	40	50	ISA
SL	Gnd Roll	1029	1066	1104	1141	1179	1217	1085
	Total	2704	2768	2833	2899	2966	3033	2800
1000	Gnd Roll	1067	1106	1145	1184	1223	1262	1117
	Total	2768	2836	2904	2974	3044	3115	2856
2000	Gnd Roll	1106	1147	1187	1228	1268	1309	1151
	Total	2837	2908	2980	3053	3127	3202	2915
3000	Gnd Roll	1148	1190	1232	1274	1316	1358	1186
	Total	2909	2984	3060	3137	3216	3295	2977
4000	Gnd Roll	1191	1234	1278	1322	1365	1409	1222
	Total	2987	3066	3146	3227	3309	3392	3042
5000	Gnd Roll	1236	1281	1327	1372	1417	1462	1259
	Total	3069	3152	3236	3322	3408	3496	3111
6000	Gnd Roll	1283	1330	1377	1424	1471	1518	1298
	Total	3156	3243	3332	3422	3513	3605	3183
7000	Gnd Roll	1333	1382	1431	1479	1528	1577	1338
	Total	3248	3340	3434	3529	3624	3721	3258
8000	Gnd Roll	1385	1435	1486	1537	1587	1638	1380
	Total	3346	3443	3542	3642	3742	3844	3338
9000	Gnd Roll	1439	1492	1544	1597	1650	1702	1424
	Total	3450	3553	3656	3761	3867	3974	3421
10,000	Gnd Roll	1496	1550	1605	1660	1715	1769	1469
	Total	3560	3668	3778	3888	4000	4112	3509

Landing Distance Table - Flaps 0%

Weight: 3150 lb (1429 kg)	Headwind: Subtract 10% per each 13 knots headwind.
Speed over 50 ft Obstacle: 87 KIAS	Tailwind: Add 10% per each 2 knots tailwind up to 10 knots.
Flaps: 0%	Runway Slope: Refer to list of factors.
Power: Idle	Dry Grass: Add 20% to ground roll.
Runway: Dry, Level, Paved	Wet Grass: Add 60% to ground roll.

Press Alt FT	Distance FT	TEMPERATURE ~°C						
		0	10	20	30	40	50	ISA
SL	Gnd Roll	1185	1228	1272	1315	1358	1402	1250
	Total	2971	3037	3105	3174	3243	3314	3071
1000	Gnd Roll	1229	1274	1319	1364	1409	1454	1287
	Total	3038	3108	3179	3252	3325	3399	3130
2000	Gnd Roll	1274	1321	1368	1414	1461	1508	1326
	Total	3109	3183	3258	3335	3412	3490	3191
3000	Gnd Roll	1322	1371	1419	1467	1516	1564	1366
	Total	3185	3263	3342	3422	3504	3586	3256
4000	Gnd Roll	1372	1422	1472	1523	1573	1623	1408
	Total	3265	3348	3431	3515	3601	3688	3323
5000	Gnd Roll	1424	1476	1528	1581	1633	1685	1451
	Total	3351	3437	3525	3614	3704	3795	3395
6000	Gnd Roll	1479	1533	1587	1641	1695	1749	1495
	Total	3441	3533	3625	3719	3814	3910	3470
7000	Gnd Roll	1536	1592	1648	1704	1760	1817	1542
	Total	3537	3634	3731	3830	3930	4031	3548
8000	Gnd Roll	1595	1654	1712	1770	1829	1887	1590
	Total	3640	3741	3844	3948	4053	4159	3631
9000	Gnd Roll	1658	1718	1779	1840	1900	1961	1641
	Total	3748	3855	3963	4073	4183	4295	3718
10,000	Gnd Roll	1723	1786	1849	1912	1975	2038	1693
	Total	3863	3976	4090	4205	4322	4439	3809

Section 6: Weight and Balance

Table of Contents

Introduction.....	3
Weight and Balance Record.....	3
Weight and Balance Data.....	3
Loading Instructions	4
Weight and Balance Loading Form	5
Loading Data	6
Moment Limits	7
Weight & Balance Record	8
Equipment List.....	8

Intentionally Left Blank

Introduction

This section describes the procedure for calculating the weight and moment for various operations. A comprehensive list of all equipment available for this airplane is included at the back of this section.

It should be noted that specific information regarding the weight, arm, moment, and installed equipment for this airplane as delivered from the factory can be found at the back of this section.

It is the responsibility of the pilot to ensure that the airplane is loaded properly and that all changes to the basic empty weight and center of gravity are recorded.

Figure 6-1: Airplane Weighing

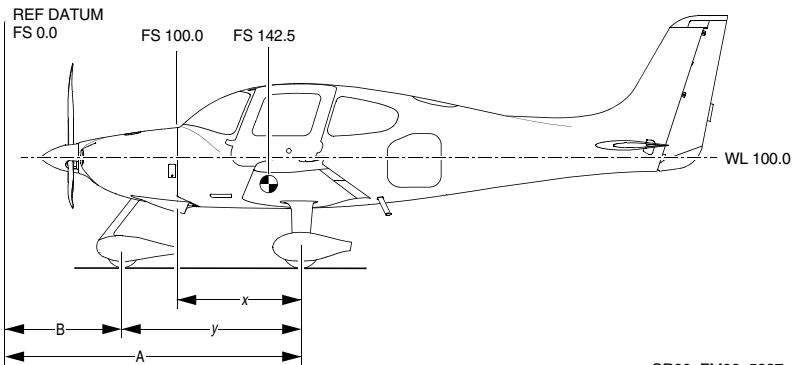

SR20_FM06_5337

Basic empty weight, moment, and center of gravity are provided in inches aft of datum, where 0 inches datum is 100.0 inches forward of the cabin fire-wall. CG can also be expressed in terms of its location as a percentage of the airplane Mean Aerodynamic Cord (MAC) using the following formula:

$$CG\% \text{ MAC} = 100 \times (CG \text{ Inches} - LEMAC) / MAC$$

Where:

$$LEMAC = 133.1$$

$$MAC = 47.7$$

• NOTE •

Refer to AMM Chapter 8: Leveling & Weighing for instructions.

Weight and Balance Record

Weight and Balance Data

Refer to “As-Delivered” Weight and Balance Data.

Loading Instructions

It is the responsibility of the pilot to ensure that the airplane is properly loaded and operated within the prescribed weight and center of gravity limits. The following information enables the pilot to calculate the total weight and moment for the loading. The calculated moment is then compared to the Moment Limits chart or table (Figure 6-4) for a determination of proper loading.

Airplane loading determinations are calculated using the Weight & Balance Loading Form (Figure 6-2), the Loading Data chart and table (Figure 6-3), and the Moment Limits chart and table (Figure 6-4).

1. Basic Empty Weight – Enter the current Basic Empty Weight and Moment from the Weight & Balance Record (Figure 6-5).
2. Front Seat Occupants – Enter the total weight and moment/1000 for the front seat occupants from the Loading Data (Figure 6-3).
3. Rear Seat Occupants – Enter the total weight and moment/1000 for the rear seat occupants from the Loading Data (Figure 6-3).
4. Baggage – Enter weight and moment for the baggage from the Loading Data (Figure 6-3).

• NOTE •

If desired, subtotal the weights and moment/1000 from steps 1 through 4. This is the Zero Fuel Condition. It includes all useful load items excluding fuel.

5. Fuel Loading – Enter the weight and moment of usable fuel loaded on the airplane from the Loading Data (Figure 6-3).

• NOTE •

Subtotal the weight and moment/1000. This is the Ramp Condition or the weight and moment of the aircraft before taxi.

6. Fuel for start, taxi, and run-up – This value is pre-entered on the form. Normally, fuel used for start, taxi, and run-up is approximately 9 pounds at an average moment/1000 of 1.394.
7. Takeoff Condition – Subtract the weight and moment/1000 for step 6 (start, taxi, and run-up) from the Ramp Condition values (step 5) to determine the Takeoff Condition weight and moment/1000.

• NOTE •

The total weight at takeoff must not exceed the maximum weight limit of 3150 pounds. The total moment/1000 must not be above the maximum or below the minimum moment/1000 for the Takeoff Condition Weight as determined from the Moment Limits chart or table (Figure 6-4).

Weight and Balance Loading Form

• NOTE •

The Takeoff Condition Weight must not exceed 3150 lb.

The Takeoff Condition Moment must be within the Minimum Moment to Maximum Moment range at the Takeoff Condition Weight. (Refer to Moment Limits).

RELATED TABLE/FIGURE:

For Center of Gravity Envelope, refer to [Section 2: Limitations](#).

Serial Num:

Date:.....

Reg. Num:

Initials:.....

Figure 6-2: Weight & Balance Loading Form

Item	Description	Weight LB	Moment/1000
1.	Basic Empty Weight Includes unusable fuel & full oil		
2.	Front Seat Occupants Pilot & Passenger (total)		
3.	Rear Seat Occupants		
4.	Baggage Area 130 lb maximum		
5.	Zero Fuel Condition Weight Sub total item 1 thru 4		
6.	Fuel Loading 56 Gallon @ 6.0 lb/gal. Maximum		
7.	Ramp Condition Weight Sub total items 5 and 6		
8.	Fuel for start, taxi, and run-up Normally 9 lb at average moment of 1394		
9.	Takeoff Condition Weight Subtract item 8 from item 7		

Loading Data

Use the following chart or table to determine the moment/1000 for fuel and payload items to complete the Loading Form.

Figure 6-3: Loading Chart

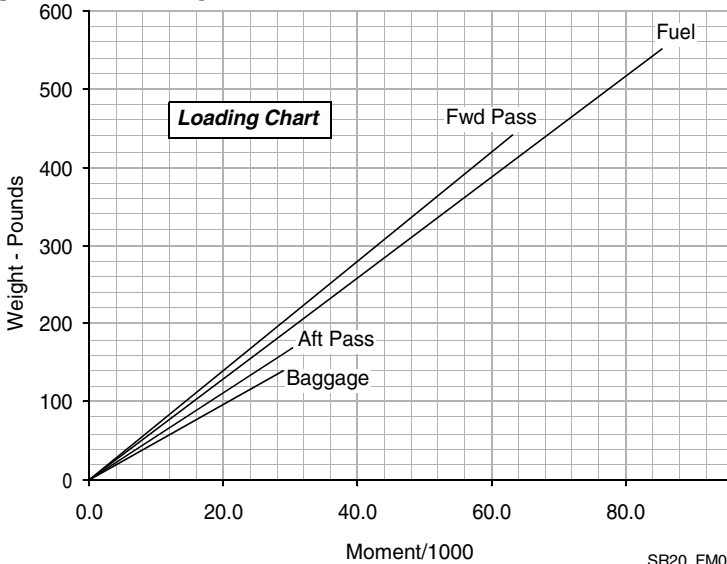

SR20_FM06_5339

Weight LB	Fwd Pass FS 143.5	Aft Pass FS 180.0	Baggage FS 208.0	Fuel FS 154.9	Weight LB	Fwd Pass FS 143.5	Aft Pass FS 180.0	Fuel FS 154.9
20	2.87	3.60	4.16	3.10	220	31.57	39.60	34.08
40	5.74	7.20	8.32	6.20	240	34.44	43.20	37.18
60	8.61	10.80	12.48	9.29	260	37.31	46.80	40.27
80	11.48	14.40	16.64	12.39	280	40.18	50.40	43.37
100	14.35	18.00	20.80	15.49	300	43.05	54.00	46.47
120	17.22	21.60	24.96	18.59	320	45.92	57.60	49.57
140	20.09	25.20	27.04*	21.69	336**	48.79	61.20	52.05
160	22.96	28.80		24.78	360	51.66	64.80	
180	25.83	32.40		27.88	380	54.53	68.40	
200	28.70	36.00		30.98	400	57.40	72.00	
*130 lb Maximum					**56 U. S. Gallons Usable			

Section 7: Airplane and Systems

Table of Contents

Introduction.....	5
Airframe.....	5
Fuselage.....	5
Wings.....	5
Empennage.....	6
Flight Controls.....	6
Elevator System.....	6
Aileron System.....	9
Rudder System.....	11
Control Locks.....	11
Instrument Panel.....	13
Pilot Panel Arrangement.....	13
Center Console Arrangement.....	13
Bolster Panel Arrangement.....	13
Flight Instruments.....	16
Attitude Indicator.....	18
Airspeed Indicator.....	19
Altimeter.....	20
Horizontal Situation Indicator.....	21
Vertical Speed Indicator.....	22
Magnetic Compass (IF installed).....	22
Wing Flaps.....	22
Flap Control Switch.....	23
Landing Gear.....	25
Main Gear.....	25
Nose Gear.....	25
Brake System.....	25
Baggage Compartment.....	26
Baggage Tie-Downs/Cargo Net.....	27
Seats.....	27
Front Seats.....	28
Rear Seats.....	29
Seat Belt and Shoulder Harness.....	29
Front Seat Inflatable Restraints.....	30
Child Restraint System.....	31
Cabin Doors.....	33

Key Fob	33
Windshield and Windows	33
Engine	33
Engine Controls	34
Engine Indicating	35
Engine Lubrication System	38
Ignition and Starter System	39
Air Induction System	39
Engine Exhaust	39
Engine Fuel Injection	40
Engine Cooling	40
Propeller	40
Fuel System	41
Fuel Selector Valve	42
Fuel Pump Operation	42
Fuel Indicating	44
Mixture Management	48
Electrical System	49
Power Generation	49
Power Distribution	51
Electrical System Protection	52
Electrical System Control	55
Ground Service Receptacle	56
Electrical Indicating	56
Lighting Systems	59
Exterior Lighting	59
Interior Lighting	59
Convenience Lighting	60
Environmental System	62
Distribution	65
Heating	65
Cooling	65
Airflow Selection	66
Vent Selection	66
Temperature Selection	67
Stall Warning System	69
Pitot-Static System	69
Pitot Heat Switch	69
Pitot Heat Annunciation	70
Alternate Static Source	70
Avionics	73
Perspective+ Integrated Avionics System	73

Avionics Support Equipment	90
Cabin Features.....	92
Emergency Locator Transmitter (ELT)	92
Fire Extinguisher	94
Hour Meters.....	95
Emergency Egress Hammer	95
Convenience Outlet(s).....	95
USB Ports.....	96
Cirrus Airframe Parachute System.....	97
System Description	97
Activation Handle	98
Deployment Characteristics	99

Intentionally Left Blank

Cabin Features

Fire Extinguisher

A liquefied-gas-type fire extinguisher is mounted on the forward inboard side of the copilot footwell. The extinguishing agent is Halon 1211 or Halotron BrX . The extinguisher is approved for use on class B (liquid, grease) and class C (electrical equipment) fires. A pin is installed through the discharge mechanism to prevent inadvertent discharge of extinguishing agent.

Serials w/ Halotron fire extinguisher: The fire extinguisher must be replaced after each use.

Serials w/ Halon fire extinguisher: The fire extinguisher must be replaced or refilled after each use.

To Operate Extinguisher

1. Loosen retaining clamp and remove the extinguisher from its mounting bracket.
2. Hold the extinguisher upright and pull the pin.
3. Get back from the fire and aim nozzle at base of fire at the nearest edge.
4. Press lever and sweep side to side.

• WARNING •

The gas used in the fire extinguisher can be toxic, especially in a closed area. After discharging fire extinguisher, ventilate cabin by opening air vents and unlatching door. Close vents and door after fumes clear.

The extinguisher must be inspected before each flight to ensure that it is available, charged, and operable. The preflight inspection consists of ensuring that the nozzle is unobstructed, the pin has not been pulled, and the canister has not been damaged.

For preflight, charge can be determined by verifying the gauge pressure is in the operable (green) range, or by 'hefting' the unit.

Serials w/ Halon fire extinguisher: The unit should weigh approximately 2.5 lb (1.1 kg).

Serials w/ Halotron fire extinguisher: The unit should weigh approximately 3.0 lb (1.4 kg).

Intentionally Left Blank

Introduction

This section provides a basic description and operation of the standard airplane and its systems. Optional equipment described within this section is identified as optional.

• NOTE •

Some optional equipment may not be described in this section.

For description and operation of optional equipment not described in this section, refer to [Section 9: Log of Supplements](#).

Airframe

Fuselage

The airplane's monocoque fuselage is constructed primarily of composite materials and is designed to be aerodynamically efficient. The cabin area is bounded on the forward side by the firewall at fuselage station 100, and on the rear by the aft baggage compartment bulkhead at fuselage station 222. Comfortable seating is provided for the pilot and up to four passengers. A composite roll cage within the fuselage structure provides roll protection for the cabin occupants. The cabin and baggage compartment floors are constructed of a foam core composite with access to under-floor components.

All flight and static loads are transferred to the fuselage structure from the wings and control surfaces through four wing attach points in two locations under the front seats and two locations on the sidewall just aft of the rear seats.

The lower firewall employs a 20° bevel to improve crashworthiness. In addition, an avionics bay is located aft of bulkhead 222 and accessible through an access panel installed on the RH side of the aft fuselage.

Wings

The wing structure is constructed of composite materials producing wing surfaces that are smooth and seamless. The wing cross section is a blend of several high performance airfoils. A high aspect ratio results in low drag. Each wing provides attach structure for the main landing gear and contains a 29.3-gallon fuel tank.

The wing is constructed in a conventional spar, rib, and shear section arrangement. The upper and lower skins are bonded to the spar, ribs, and aft shear web forming a torsion box that carries all of the wing bending and torsion loads. The rear shear webs are similar in construction but do not carry through the fuselage. The main spar is laminated epoxy/carbon fiber

in a C-section, and is continuous from wing tip to wing tip. The wing spar passes under the fuselage below the two front seats and is attached to the fuselage in two locations. Lift and landing loads are carried by the single carry-through spar, plus a pair of rear shear webs (one on each wing) attached to the fuselage.

Empennage

The empennage consists of a horizontal stabilizer, a two-piece elevator, a vertical fin and a rudder. All of the empennage components are conventional spar (shear web), rib, and skin construction.

The horizontal stabilizer is a single composite structure from tip to tip. The two-piece elevator, attached to the horizontal stabilizer, is aluminum.

The vertical stabilizer is composite structure integral to the main fuselage shell for smooth transfer of flight loads. The rudder is aluminum and is attached to the vertical stabilizer rear shear web at three hinge points.

Flight Controls

The airplane uses conventional flight controls for ailerons, elevator and rudder. The control surfaces are pilot controlled through either of two single-handed side control yokes mounted beneath the instrument panel. The location and design of the control yokes allow easy, natural use by the pilot. The control system uses a combination of push rods, cables and bell cranks for control of the surfaces.

Elevator System

The two-piece elevator provides airplane pitch control. The elevator is of conventional design with skin, spar and ribs manufactured of aluminum. Each elevator half is attached to the horizontal stabilizer at two hinge points and to the fuselage tailcone at the elevator control sector. Elevator motion is generated through the pilot's control yokes by sliding the yoke tubes forward or aft in a bearing carriage. A push-pull linkage is connected to a cable sector mounted on a torque tube. A single cable system runs from the forward elevator sector under the cabin floor to the aft elevator sector pulley. A push-pull tube connected to the aft elevator sector pulley transmits motion to the elevator bellcrank attached to the elevators.

Pitch Trim System

Pitch trim is provided by adjusting the neutral position of the compression spring cartridge in the elevator control system by means of an electric motor. It is possible to easily override full trim or autopilot inputs by using normal control inputs. A ground adjustable trim tab is installed on the elevator to provide small adjustments in neutral trim. This tab is factory set and does not normally require adjustment. An electric motor changes the neutral position of the spring cartridge attached to the elevator control horn. A conical trim button located on top of each control yoke controls the

motor. Moving the switch forward will initiate nose-down trim and moving the switch aft will initiate nose-up trim. Neutral (takeoff) trim is indicated by the alignment of a reference mark on the yoke tube with a tab attached to the instrument panel bolster. The elevator trim also provides a secondary means of airplane pitch control in the event of a failure in the primary pitch control system not involving a jammed elevator.

Elevator (pitch) trim operates on 28 VDC supplied through the 2-amp PITCH TRIM circuit breaker on ESS BUS 2.

Figure 7-1: Elevator System

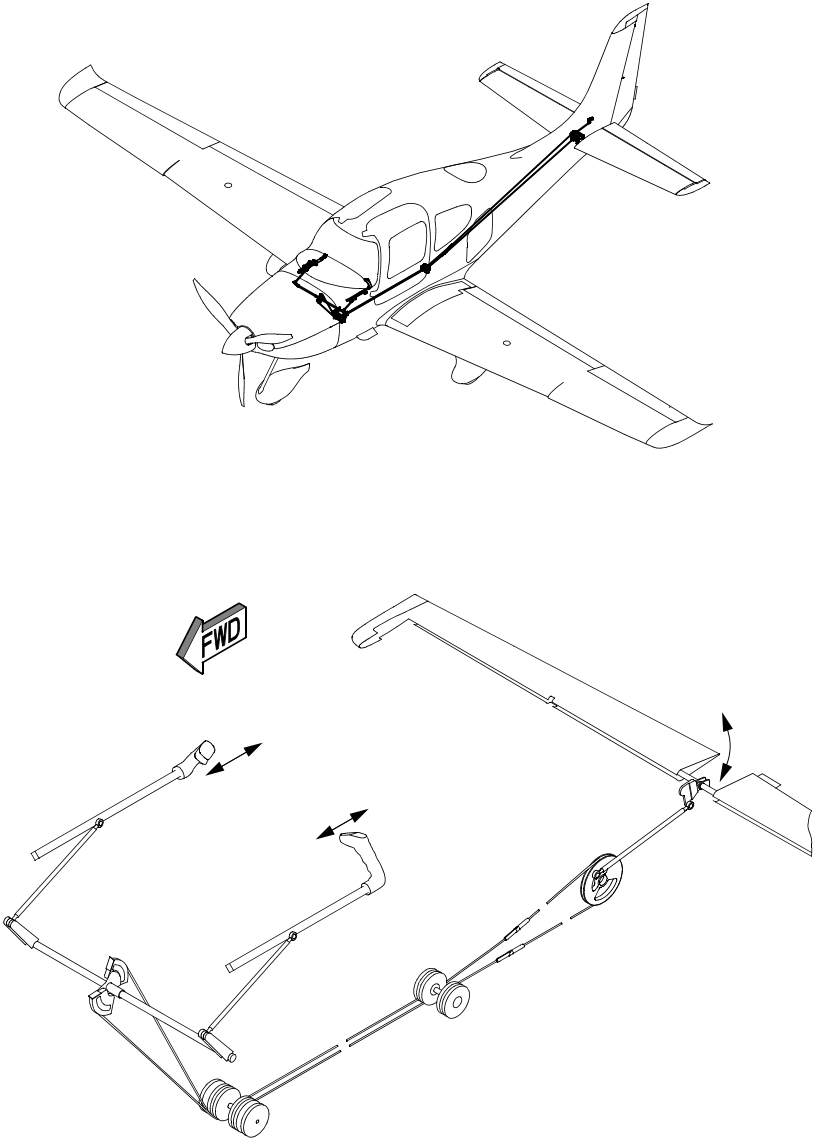

SR20_FM07_5343

Aileron System

The ailerons provide airplane roll control. The ailerons are of conventional design with skin, spar and ribs manufactured of aluminum. Each aileron is attached to the wing shear web at two hinge points.

Aileron control motion is generated through the pilot's control yokes by rotating the yokes in pivoting bearing carriages. Push rods link the pivoting carriages to a centrally located pulley sector. A single cable system runs from the sector to beneath the cabin floor and aft of the rear spar. From there, the cables are routed in each wing to a vertical sector/crank arm that rotates the aileron through a right angle conical drive arm.

Roll Trim System

Roll trim is provided by adjusting the neutral position of a compression spring cartridge in the aileron control system by means of an electric motor. The electric roll trim is also used by the autopilot to position the ailerons. It is possible to easily override full trim or autopilot inputs by using normal control inputs.

A ground adjustable trim tab is installed on the right aileron to provide small adjustments in neutral trim. This tab is factory set and does not normally require adjustment.

An electric motor changes the neutral position of a spring cartridge attached to the left actuation pulley in the wing. A conical trim button located on top of each control yoke controls the motor. Moving the switch left will initiate left-wing-down trim and moving the switch right will initiate right-wing-down trim. Neutral trim is indicated by the alignment of the line etched on the control yoke with the centering indication marked on the instrument panel. The aileron trim also provides a secondary means of airplane roll control in the event of a failure in the primary roll control system not involving jammed ailerons.

Aileron trim operates on 28 VDC supplied through the 2-amp ROLL TRIM circuit breaker on ESS BUS 2.

Figure 7-2: Aileron System

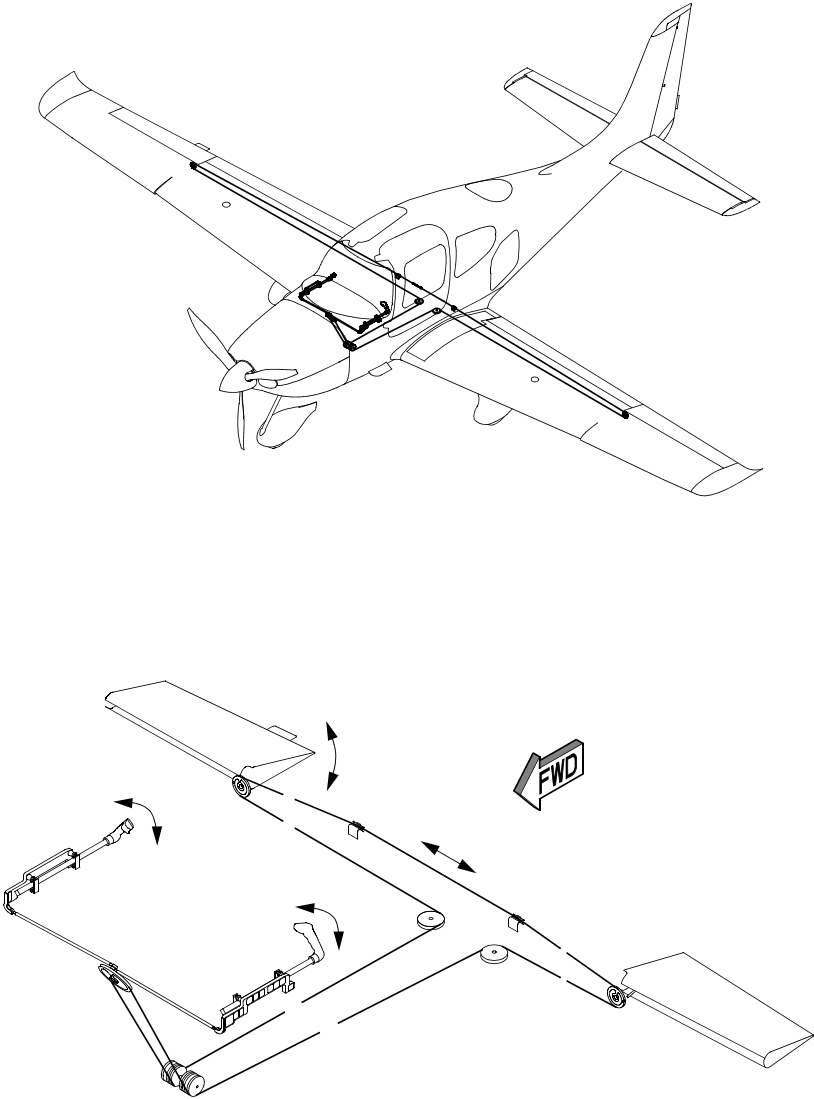

SR20_FM07_5345

Rudder System

The rudder provides airplane directional (yaw) control. The rudder is of conventional design with skin, spar and ribs manufactured of aluminum. The rudder is attached to the aft vertical stabilizer shear web at three hinge points and to the fuselage tailcone at the rudder control bell crank.

Rudder motion is transferred from the rudder pedals to the rudder by a single cable system under the cabin floor to a sector next to the elevator sector pulley in the aft fuselage. A push-pull tube from the sector to the rudder bell crank translates cable motion to the rudder. Springs and a ground adjustable spring cartridge connected to the rudder pedal assembly tension the cables and provide centering force.

Yaw Trim System

Yaw trim is provided by spring cartridge attached to the rudder pedal torque tube and console structure. The spring cartridge provides a centering force regardless of the direction of rudder deflection. The yaw trim is ground adjustable only.

A ground adjustable trim tab is installed on the rudder to provide small adjustments in neutral trim. This tab is factory set and does not normally require adjustment.

Control Locks

The airplane's control system is not equipped with gust locks. The trim spring cartridges have sufficient power to act as a gust damper without rigidly locking the position.

Figure 7-3: Rudder System

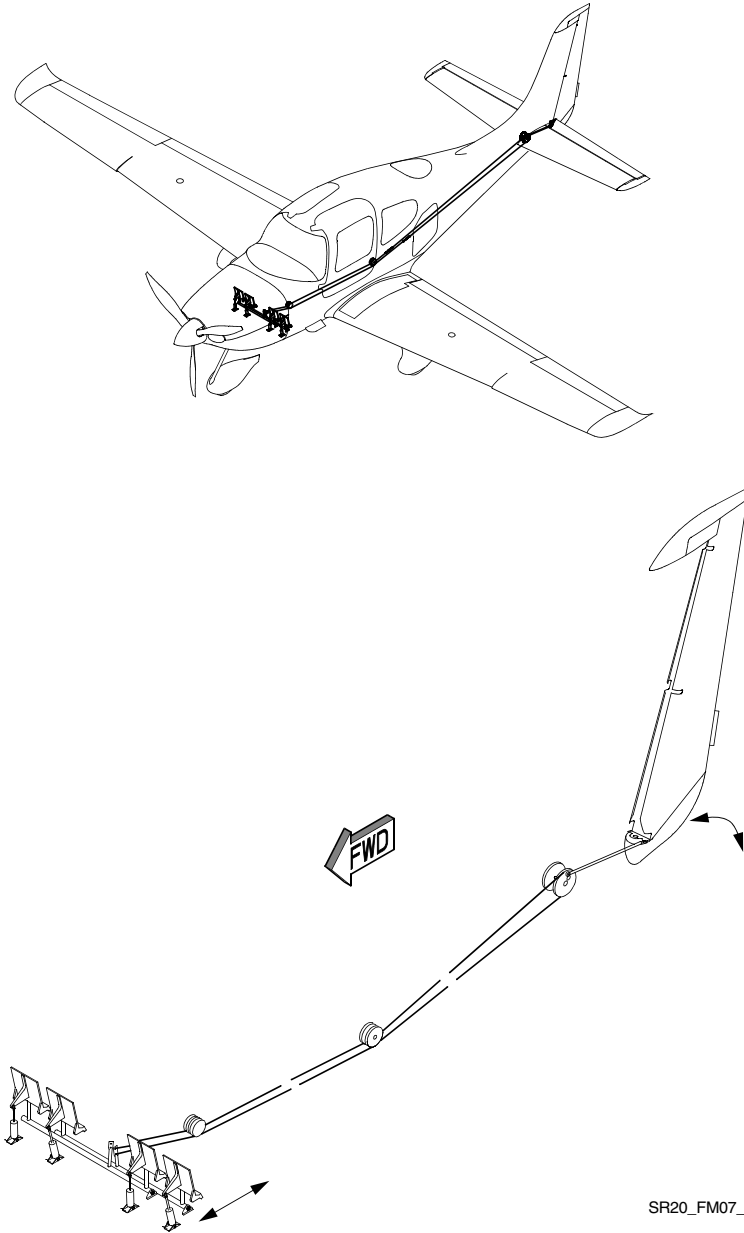

SR20_FM07_5346

Instrument Panel

The instrument panel is of all metal construction and is installed in sections so equipment can be easily removed for maintenance. The surrounding glare shield is made of composite material and projects over the instrument panel to reduce reflections on the windshield from lighted equipment and to shield the panel equipment from glare.

Pilot Panel Arrangement

Two color landscape-oriented electronic flight displays are installed to the instrument panel: the Primary Flight Display (PFD) and the Multifunction Display (MFD). The PFD, installed directly in front of the pilot, is intended to be the primary display of flight parameter information (attitude, airspeed, heading, and altitude). The MFD, installed to the right of the PFD, provides supplemental situational and navigation information to the pilot. The ignition switch is located on the left side of the instrument panel. The cabin environmental control switches are located on the right side of the instrument panel. Instrument panel air vents are located on the outboard sections of the panel.

Center Console Arrangement

A center console contains the Flight Management System Keyboard, auto-pilot and audio controls, flap system control and indication, fuel selector valve, and the power and mixture levers. System circuit breakers, the alternate static source valve, and the ELT panel switch are located on the left side of the console. A friction knob for adjusting throttle and mixture control feel and position stability is located on the right side of the console. The accessory outlet, map compartment, audio jacks, hour meters, and emergency egress hammer are installed inside the console armrest.

Bolster Panel Arrangement

A switch panel located in the “dash board” bolster below the instrument panel contains the master, avionics power, Pitot heat, and exterior and interior lighting switches and controls. The standby airspeed, attitude, and altimeter instruments are located below the bolster switch panel.

Figure 7-4: Instrument Panel & Console - Serials w/o MD302 (1 of 2)

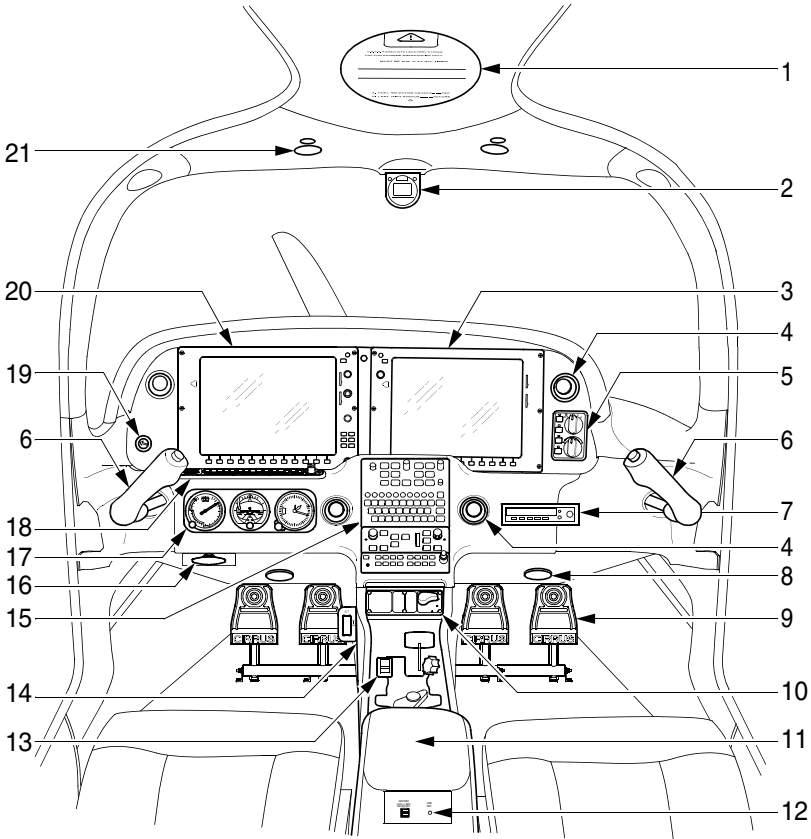

LEGEND

- | | |
|--|-----------------------------------|
| 1. Cirrus Airframe Parachute System (CAPS) Activation T-Handle Cover | 13. Engine & Fuel System Controls |
| 2. Magnetic Compass (if installed) | 14. Left Side Console |
| 3. Multifunction Display | · Circuit Breaker Panel |
| 4. Fresh Air "Eyeball" Outlet | · ELT Remote Switch |
| 5. Temperature/Ventilation Controls | · Alternate Static Source |
| 6. Control Yoke | 15. Avionics Panel |
| 7. ADF (opt) | 16. Parking Brake |
| 8. Conditioned Air Outlet | 17. Flight Instrument Panel |
| 9. Rudder Pedals | 18. Bolster Switch Panel |
| 10. Flap Control & Position Indicators | 19. Start/Ignition Key Switch |
| 11. Armrest | 20. Primary Flight Display |
| 12. Passenger Audio (if installed) & USB Jack(s) | 21. Overhead Light & Switch |

SR20_FM07_5367B

Figure 7-4: Instrument Panel & Console - Serials w/ MD302 (2 of 2)

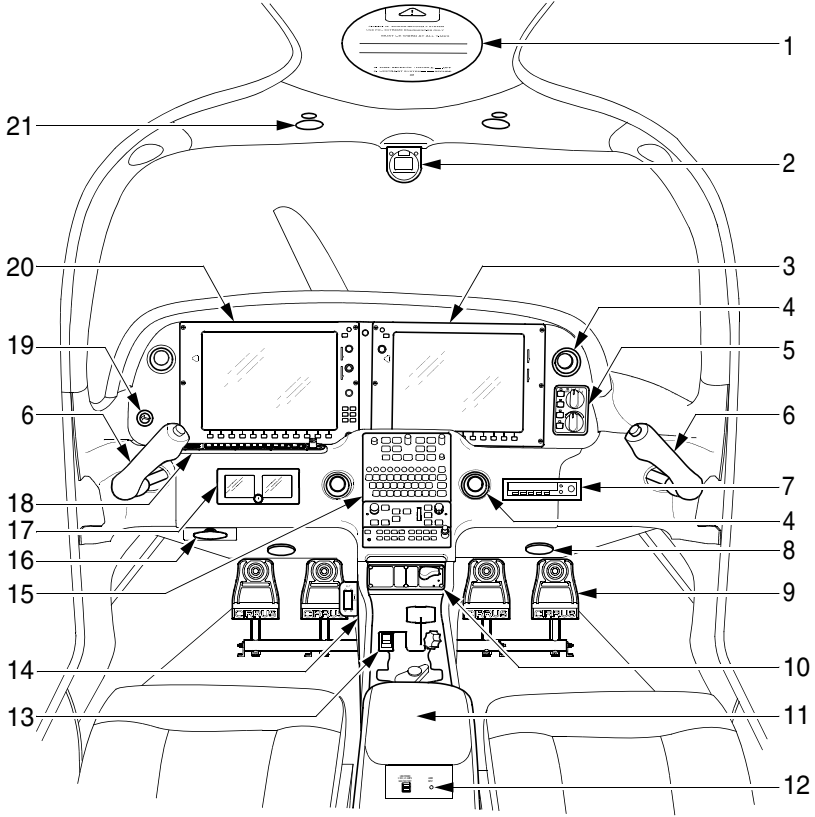

LEGEND

- | | |
|---|---|
| <ul style="list-style-type: none"> 1. Cirrus Airframe Parachute System (CAPS) Activation T-Handle Cover 2. Magnetic Compass (if installed) 3. Multifunction Display 4. Fresh Air “Eyeball” Outlet 5. Temperature/Ventilation Controls 6. Control Yoke 7. ADF (opt) 8. Conditioned Air Outlet 9. Rudder Pedals 10. Flap Control & Position Indicators 11. Armrest 12. Passenger Audio (if installed) & USB Jack(s) | <ul style="list-style-type: none"> 13. Engine & Fuel System Controls 14. Left Side Console <ul style="list-style-type: none"> · Circuit Breaker Panel · ELT Remote Switch · Alternate Static Source 15. Avionics Panel 16. Parking Brake 17. Flight Instrument Panel 18. Bolster Switch Panel 19. Start/Ignition Key Switch 20. Primary Flight Display 21. Overhead Light & Switch |
|---|---|

SR20_FM07_5368B

Flight Instruments

Flight instruments and annunciations are displayed on the Primary Flight Display (PFD) located directly in front of the pilot. The PFD presents the primary flight instruments arranged in the conventional basic “T” configuration. Standby instruments for airspeed, attitude, and altitude are mounted on the LH bolster panel and are powered independently of the PFD.

Knobs, knob sets, and membrane-type push button switches are located along the inboard edge of the PFD and MFD and provide control for communication (COM), navigation (NAV), heading (HDG), barometric pressure set (BARO), and various Flight Management functions. For electrical requirements and additional information on PFD and MFD integration, refer to the [Perspective+ Integrated Avionics System](#) description in this section.

Figure 7-5: Flight Instruments

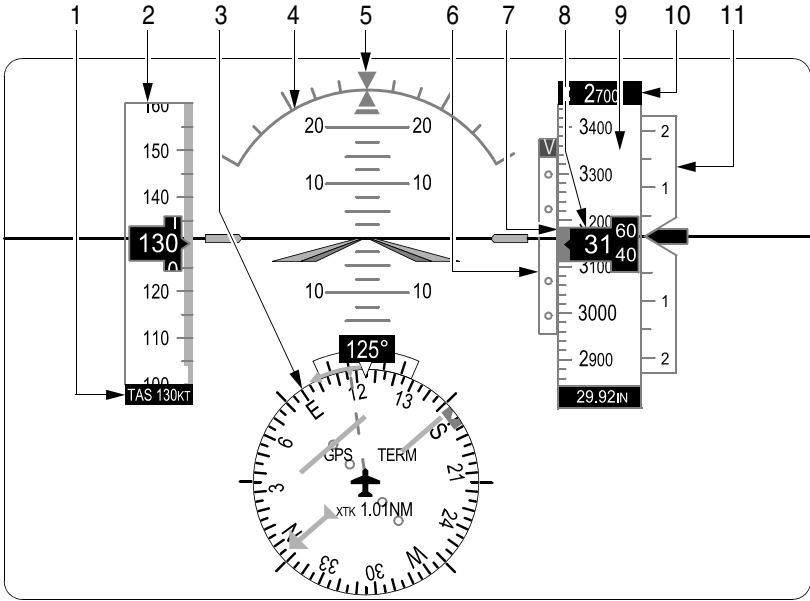

LEGEND

1. True Airspeed
2. Airspeed Indicator
3. Horizontal Situation Indicator (HSI)
4. Attitude Indicator
5. Slip/Skid Indicator
6. Vertical Deviation Indicator (VDI)
7. Selected Altitude Bug
8. Current Altitude
9. Altimeter
10. Selected Altitude
11. Vertical Speed Indicator (VSI)

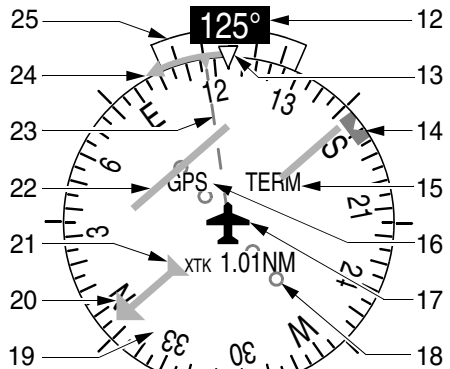

HSI DETAIL
Typical View

12. Current Heading
13. Lubber Line
14. Selected Heading Bug
15. Flight Phase
16. Navigation Source
17. Aircraft Symbol
18. Course Deviation Scale
19. Rotating Compass Rose
20. Course Pointer
21. To/From Indicator
22. Course Deviation Indicator
23. Current Track Indicator
24. Turn Rate/Heading Trend Vector
25. Turn Rate Indicator

SR20_FM07_5348

Attitude Indicator

The primary attitude indicator is shown on the upper center of the PFD and displays pitch, roll, and slip/skid information provided by the Attitude and Heading Reference System (AHRS).

Above and below the horizon line, major pitch marks and labels are shown for every 10°, up to 80°. Between 25° below and 45° above the horizon line, the pitch index scale is graduated in 5° increments with every 10° of pitch labeled. Between 20° below and 20° above the horizon line, minor pitch marks occur every 2.5°. If pitch limits are exceeded in either the nose-up or nose-down attitude, red warning chevrons will appear and point the way back to level flight. The roll index scale is graduated with major tick marks at 30° and 60° and minor tick marks at 10°, 20°, and 45°. The roll pointer is slaved to the airplane symbol. The slip-skid indicator is the bar beneath the roll pointer. The indicator moves with the roll pointer and moves laterally away from the pointer to indicate lateral acceleration. Slip/skid is indicated by the location of the bar relative to the pointer. One bar displacement is equal to one ball displacement on a traditional slip/skid indicator.

Standby Attitude Indicator

Serials w/o MD302 Standby Attitude Module:

The standby attitude indicator is mounted on the LH bolster panel and provides backup indication of flight attitude. Bank attitude is indicated by a pointer at the top of the indicator relative to the bank scale with index marks at 10°, 20°, 30°, 60°, and 90° either side of the center mark. A fixed miniature airplane superimposed over a movable mask containing a white symbolic horizon bar, which divides the mask into two sections, indicates pitch and roll attitudes. The upper “blue sky” section and the lower “earth” sections have pitch reference lines useful for pitch attitude control. A knob at the bottom of the instrument allows adjustment of the miniature airplane to the horizon bar for a more accurate flight attitude indication. A PULL TO CAGE knob on the indicator is used for quick erection of the gyro. When the caging knob is pulled, the pitch and roll indications will align to within 2° of their respective fixed references. The standby attitude indicator is electrically driven. A red GYRO flag indicates loss of electrical power. Redundant circuits paralleled through diodes at the indicator supply DC electrical power for gyro operation.

Serials w/ MD302 Standby Attitude Module:

The MD302 Standby Attitude Module is mounted on the LH bolster panel and gives backup indication of flight attitude. Bank attitude is indicated by a pointer at the top of the indicator relative to the bank scale with index marks at 0° (triangle), 10°, 20°, 30°, 45° (small triangle), and 60° either side of the center mark. A fixed, user-configurable airplane symbol is superimposed over a movable background containing a white horizon bar that divides the attitude display into two sections: upper “blue sky” and lower

“earth”. The pitch scale on the attitude display is graduated in 5° increments. Chevrons appear on the pitch scale at extreme pitch attitudes. The MD302 Standby Attitude Module is electrically driven. A red X indicates the attitude display is absent due to exceedance of internal rate sensors, loss of airspeed, or other reasons. Redundant circuits paralleled through diodes supply DC electrical power to the unit.

All Serials:

28 VDC for the standby attitude indicator is supplied through the 5-amp STDBY ATTD A circuit breaker on ESS BUS 1 and the 5-amp STDBY ATTD B circuit breaker on MAIN BUS 1.

Airspeed Indicator

Primary airspeed data is provided by the Air Data Computer and is shown as a vertical tape along the upper left side of the PFD. The airspeed scale is graduated with major tick marks at intervals of 10 knots and minor tick marks at intervals of 5 knots. Speed indication starts at 20 knots, with 60 knots of airspeed viewable at any time. The actual airspeed is displayed inside the black pointer. The pointer remains black until reaching the never-exceed speed (V_{NE}), at which point it turns red. Color coded bars are provided to indicate flap operating range, normal operating range, caution range, and never-exceed speed. Speeds above the never-exceed speed, appear in the high speed warning range, represented on the airspeed tape by red/white “barber pole” coloration. Calculated true airspeed is displayed in window at the bottom edge of the airspeed tape. Airspeed trend is also displayed as a bar along side of the airspeed tape.

Standby Airspeed Indicator

Serials w/o MD302 Standby Attitude Module:

The standby airspeed indicator is mounted on the LH bolster panel and displays indicated and true airspeeds on a dual-scale, internally lit precision airspeed indicator installed in the pilot's instrument panel. The instrument senses difference in static and Pitot pressures and displays the result in knots on an airspeed scale. A single pointer sweeps an indicated airspeed scale calibrated from 40 to 220 knots. The 'zero' index is at the 12 o'clock position. A sub-scale aligns true airspeed with the corresponding indicated airspeed when the altitude/temperature correction is set in the correction window. A knob in the lower left corner of the instrument is used to rotate the pressure altitude scale in the correction window to align the current pressure altitude with the outside air temperature.

Serials w/ MD302 Standby Attitude Module:

The MD302 Standby Attitude Module is mounted on the LH bolster panel and displays the current Indicated Airspeed (IAS). The instrument senses difference in static and pitot pressures and displays the result in knots in the Airspeed Window. The Airspeed Window/Pointer sweeps the indicated

airspeed tape and denotes the current airspeed. Color coded bars are provided to indicate flap operating range, normal operating range, caution range, and never-exceed speed.

28 VDC for the MD302 Standby Attitude Module is supplied through the 5-amp STDBY ATTD A circuit breaker on ESS BUS 1 and the 5-amp STDBY ATTD B circuit breaker on MAIN BUS 1.

Altimeter

Primary altitude data is provided by the Air Data Computer and is shown as a vertical tape along the upper right side of the PFD. The altimeter scale is graduated with major tick marks at intervals of 100 feet and minor tick marks at intervals of 20 feet. Six hundred (600) feet of barometric altitude is viewable at any time.

The local barometric pressure is set using the barometric adjustment knob on the PFD. The selectable altitude reference bug is displayed on the altimeter tape and is set using the altitude selection knob on the Flight Management System Keyboard. Barometric minimum descent altitude (MDA, or Decision Height, DH), can be preset. Altimeter trend is also displayed as a bar along side of the altimeter tape.

The PFD Altitude is corrected for static source position error (normal static source / 0% flaps), the altitude calibration errors for the PFD are zero with flaps up and normal source (typical cruise flight). Calibration corrections are only necessary when flaps are extended or the alternate static source is selected.

Standby Altimeter

Serials w/o MD302 Standby Attitude Module:

Airplane altitude is depicted on a conventional, three-pointer, internally lit barometric altimeter installed on the LH bolster panel. The instrument senses the local barometric pressure adjusted for altimeter setting and displays the result on the instrument in feet. The altimeter is calibrated for operation between -1000 and 20,000 feet altitude. The scale is marked from 0 to 10 in increments of 2. The long pointer indicates hundreds of feet and sweeps the scale every 1000 feet (each increment equals 20 feet). The short, wide pointer indicates thousands of feet and sweeps the scale every 10,000 feet (each increment equals 200 feet). The short narrow pointer indicates tens of thousands feet and sweeps from 0 (zero) to 2 (20,000 feet with each increment equal to 2000 feet). Barometric windows on the instrument's face allow barometric calibrations in either inches of mercury (in.Hg) or millibars (mb). The barometric altimeter settings are input through the barometric adjustment knob at the lower left of the instrument.

Serials w/ MD302 Standby Attitude Module:

The MD302 Standby Attitude Module is mounted on the LH bolster panel and displays the current barometric corrected altitude. The instrument senses the local barometric pressure adjusted for altimeter setting and displays the result in the Altitude Window. The altitude units are user-configurable in feet or meters. The Altitude Window/Pointer sweeps the altitude tape and denotes the current BARO-corrected altitude. The BARO Window shows the currently selected barometric altitude. The BARO units are user-configurable in IN.HG or MBAR. The barometric setting on the MD302 will automatically synchronize to the setting on the Garmin avionics, and can be manually adjusted by turning the Control Knob while in Flight Mode.

28 VDC for the MD302 Standby Attitude Module is supplied through the 5-amp STDBY ATTD A circuit breaker on ESS BUS 1 and the 5-amp STDBY ATTD B circuit breaker on MAIN BUS 1.

All Serials:

The standby altimeter does not have automatic position error corrections; calibration corrections are necessary. Because the PFD has automatic corrections and the standby does not, differences between the two indications are typical (difference is the greatest at high altitudes and high airspeeds, where the position error corrections are the highest).

Horizontal Situation Indicator

The horizontal situation indicator is displayed along the lower center of the PFD. Heading data is provided by the Attitude and Heading Reference System (AHRS) and the onboard magnetometers. The HSI displays a rotating compass card in a heading-up orientation. Letters indicate the cardinal points and numeric labels occur every 30°. Major tick marks are at 10° intervals and minor tick marks at 5° intervals. Reference index marks are provided at 45° intervals around the compass card. A circular segment scale directly above the rotating compass card shows half and standard rates of turn based on the length of the turn rate trend vector.

The HSI presents heading, turn rate, course deviation, bearing, and navigation source information in a 360° compass-rose format. The HSI contains a Course Deviation Indicator (CDI) with a course pointer arrow, a To/From arrow, a sliding deviation bar, and scale. The course pointer is a single line arrow (GPS, VOR1, and LOC1) or a double line arrow (VOR2 and LOC2) which points in the direction of the set course. The To/From arrow rotates with the course pointer and is displayed when the active NAVAID is received.

The HSI heading reference bug is set using the HDG select knob on the GMC 707 AFCS. The selected heading is displayed in a window above the upper LH 45° index mark and will disappear approximately 3 seconds after the HDG select knob stops turning.

The Course Deviation Indicator (CDI) navigation source shown on the HSI is set using the CDI softkey to select GPS, NAV1, or NAV2 inputs. The course pointer is set on the GCU 479 FMS Keyboard by selecting the CRS button and then selecting the desired course by turning the multi-function knob. The selected course is displayed in a window above the upper RH 45° index mark and will disappear approximately 3 seconds after the CRS select knob stops turning.

Vertical Speed Indicator

Vertical Speed data is provided by the Air Data Computer and is shown as a vertical tape along the right side of the altimeter on the PFD. The VSI scale is graduated with major tick marks at 1000 and 2000 fpm in each direction and minor tick marks at intervals of 500 feet. The vertical speed pointer moves up and down the fixed VSI scale and shows the rate of climb or descent in digits inside the pointer. A reference notch at the RH edge of the scale indicates 0 feet/min.

Vertical speed must exceed 100 feet/min before digits will appear in the VSI pointer. If the rate of ascent/descent exceeds 2000 fpm, the pointer appears at the corresponding edge of the tape and the rate appears inside the pointer.

Serials w/ MD302 Standby Attitude Module:

The Altitude Trend Bar is located along the right margin of the Altitude Display. This feature is optional and can be turned on or off by the user.

| Magnetic Compass (if installed)

A conventional, internally lighted, liquid filled, magnetic compass is installed on the cabin headliner immediately above the windshield. A compass correction card is installed with the compass.

• NOTE •

Refer to FAA Advisory Circular (AC) 43.13-1B for a list of occasions requiring a compass swing. If a compass swing is required, perform Operational Test - Magnetic Compass Calibration (refer to AMM 34-20, Attitude and Direction).

Wing Flaps

The electrically controlled, single-slotted flaps provide low-speed lift enhancement. Each flap is manufactured of aluminum and connected to the wing structure at three hinge points. Rub strips are installed on the top leading edge of each flap to prevent contact between the flap and wing flap cove. The flaps are selectively set to three positions: 0%, 50% (16°) and 100% (32°) by operating the FLAP control switch. The FLAP control switch positions the flaps through a motorized linear actuator mechanically connected to both flaps by a torque tube. Proximity switches in the actuator limit flap travel to the selected position and provide position indication.

The wing flaps actuator, flap control switch and indicator lights are powered by 28 VDC through the 10-amp FLAPS circuit breaker on NON ESS BUS.

Flap Control Switch

An airfoil-shaped FLAPS control switch is located at the bottom of the vertical section of the center console. The control switch is marked and has detents at three positions: UP (0%), 50% and 100%. The appropriate V_{FE} speed is marked at the Flap 50% and 100% switch positions. Setting the switch to the desired position will cause the flaps to extend or retract to the appropriate setting. An indicator light at each control switch position illuminates when the flaps reach the selected position. The UP (0%) light is green and the 50% and 100% lights are yellow.

Figure 7-6: Wing Flaps

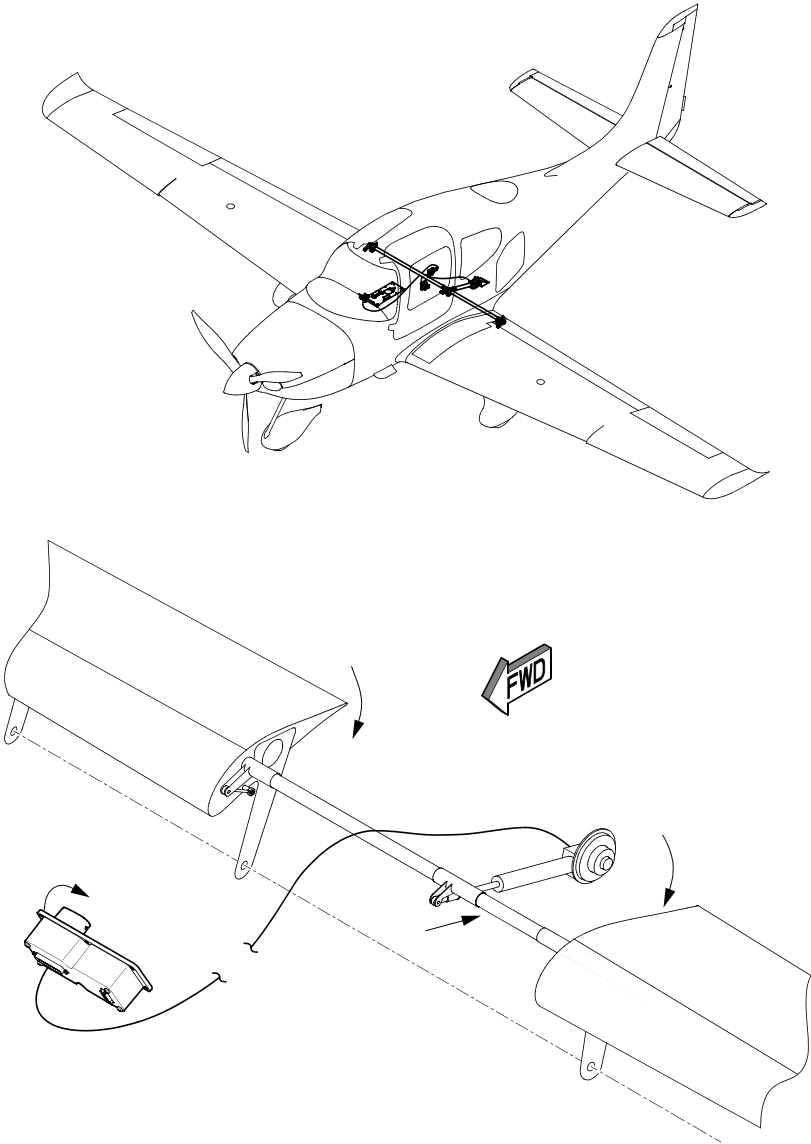

SR20_FM07_5350

Landing Gear

Main Gear

The main landing gear are bolted to composite wing structure between the wing spar and shear web. The landing gear struts are constructed of composite material for fatigue resistance. The composite construction is both rugged and maintenance free. The main wheels and wheel pants are bolted to the struts. Each main gear wheel has a 15 x 6.00 x 6 tubeless tire installed. Standard wheel pants are easily removable to provide access to tires and brakes. Access plugs in the wheel pants can be removed to allow tire inflation and pressure checking. Each main gear wheel is equipped with an independent, hydraulically operated single cylinder, dual piston, disc brake.

Nose Gear

The nose gear strut is of tubular steel construction and is attached to the steel engine mount structure. Nose gear shock absorption is provided by an oleo strut. The nose wheel is free castering and can turn through an arc of approximately 170 degrees (85 degrees either side of center). Steering is accomplished by differential application of individual main gear brakes. Each nosewheel has a 5.00 x 5 tubeless tire installed.

Brake System

The main wheels have hydraulically operated, single-disc type brakes, individually activated by floor mounted toe pedals at both pilot stations. A parking brake mechanism holds induced hydraulic pressure on the disc brakes for parking. The brake system consists of a master cylinder for each rudder pedal, a hydraulic fluid reservoir, a parking brake valve, a single disc brake assembly on each main landing gear wheel, temperature sensors, and associated hydraulic plumbing and wiring.

Braking pressure is initiated by depressing the top half of a rudder pedal (toe brake). The brakes are plumbed so that depressing either the pilot's or copilot's left or right toe brake will apply the respective (left or right) main wheel brake. The reservoir is serviced with MIL-PRF-87257 hydraulic fluid.

Brake system malfunction or impending brake failure may be indicated by a gradual decrease in braking action after brake application, noisy or dragging brakes, soft or spongy pedals, excessive travel, and/or weak braking action. A temperature sensor is mounted to each brake assembly and provides measured brake temperatures to the avionics system for caution and warning annunciation.

Should any of these symptoms occur, immediate maintenance is required. If, during taxi or landing roll, braking action decreases, let up on the toe brakes and then reapply the brakes with heavy pressure. If the brakes are spongy or pedal travel increases, pumping the pedals may build braking pressure.

Refer to Section 10, [Taxiing, Steering, and Braking Practices](#) for Brake System operational considerations.

Parking Brake

• CAUTION •

Do not set the PARK BRAKE in flight. If a landing is made with the parking brake valve set, the brakes will maintain any pressure applied after touchdown.

The main wheel brakes are set for parking by using the PARK BRAKE handle on the right side kick plate near the pilot's right knee. Brake lines from the toe brakes to the main wheel brake calipers are plumbed through a parking brake valve. For normal operation, the handle is pushed in. With the handle pushed in, poppets in the valve are mechanically held open allowing normal brake operation. When the handle is pulled out, the parking brake valve holds applied brake pressure, locking the brakes. To apply the parking brake, set the brakes with the rudder-pedal toe brakes, and then pull the PARK BRAKE handle aft.

Baggage Compartment

The baggage compartment door, located on the left side of the fuselage aft of the wing, allows entry to the baggage compartment. The baggage door is hinged on the forward edge and latched on the rear edge. The door is locked from the outside with a key lock. The baggage compartment key will also open the cabin doors.

The baggage compartment extends from behind the rear passenger seat to the aft cabin bulkhead. The rear seats can be folded forward to provide additional baggage area for long or bulky items.

Serials 8500 and subs w/ Convenience Lighting:

The baggage door is unlocked or locked from the outside with a key lock or a battery-powered key fob. Refer to [Key Fob](#) for more details.

Baggage Tie-Downs/Cargo Net

• CAUTION •

If not adequately restrained, baggage compartment items may pose a projectile hazard to cabin occupants in the event of rapid deceleration. Secure all baggage items with tie-down straps or cargo net.

Four baggage tie-down straps are provided to secure items in the baggage compartment. Each strap assembly has a hook at each end and a cam-lock buckle in the middle. The hook ends clip over loop fittings installed in the baggage floor and in the rear bulkhead. The tiedown straps should be stowed attached and tightened to the fittings.

Serials w/ 2+1 Rear Seat:

The aircraft is equipped with a retractable cargo net to secure items in the baggage compartment. Integral inertia reels attached to the rear bulkhead allow the cargo net to be extended forward, placed over baggage, and secured to the seat back via four latch assemblies. The cargo net should be stowed attached to the seat back fittings.

The cargo net is not functional when rear seats are folded forward. Use conventional tie-down straps in this configuration.

For baggage area and door dimensions, see Section 1, [Airplane Interior Dimensions](#).

Seats

The seating arrangement consists of two individually adjustable seats for the pilot and front seat passenger and, Serials w/ Observer's seat: an optional rear Observer's seat with fold-down seat back or, Serials w/ 2+1 Rear Seat: a "2+1" configuration with a one-piece bench seat and fold-down seat backs for the rear seat passengers.

• CAUTION •

Do not kneel or stand on the seats. The seat bottoms have an integral aluminum honeycomb core designed to crush under impact to absorb downward loads.

Front Seats

The front seats are adjustable fore and aft and the seat backs can be reclined for passenger comfort or folded forward for rear seat access. Integral headrests are provided. The fore and aft travel path is adjusted through the seat position control located below the forward edge of the seat cushion. The seat track is angled upward for forward travel so that shorter people will be positioned slightly higher as they adjust the seat forward. Recline position is controlled through levers located on each side of the seat backs.

Depressing the recline release control while there is no pressure on the seat back will return the seat back to the full up position.

To Position Front Seat Fore and Aft

1. Lift the position control handle.
2. Slide the seat into position.
3. Release the handle and check that the seat is locked in place.

To Adjust Recline Position

1. Actuate and hold the seat back control lever.
2. Position the seat back to the desired angle.
3. Release the control lever.

Rear Seats

To Fold Seat Back Forward (Serials w/ Observer's Seat)

The Observer's seat back reclines, and can be folded forward to provide a semi-flat surface for cargo extending forward from the baggage compartment. Recline position is controlled through a lever located on either side of the seat.

1. With no pressure on the seat back, rotate the lever to the recline position and fold the seat back forward.

To Fold Seat Back Forward (Serials w/ 2+1 Rear Seat)

The rear seats employ a one-piece bench seat and two seat backs configured in 60/40 split. This "2+1" seating configuration provides for a center seat/restraint area for a third passenger on the wider left hand seat.

Each seat back reclines independently of each other and can be folded forward to provide a semi-flat surface for cargo extending forward from the baggage compartment. Recline position is controlled through a lever located on either side of the seat.

1. With no pressure on the seat back, rotate the lever to the recline position and fold the seat back forward.

Seat Belt and Shoulder Harness

Integrated seat belt and shoulder harness assemblies with inertia reels are provided for the pilot and each passenger.

The front seats use a 4-point inflatable restraint system. Forward seat belts are attached to the seat frame. The shoulder harnesses are attached to inertia reels mounted in the seat back.

Serials w/ Observer's seat or w/ 2+1 Rear Seat: The rear seats use a 3-point safety harness consisting of one shoulder harness and a lap belt. The rear seat belts are attached to fittings on the cabin floor. The shoulder harnesses are attached to inertia reels mounted to the baggage compartment rear bulkhead.

Each front and rear seat shoulder harness is attached to the seat belt. The inertia reels allow complete freedom of movement of the occupant's upper torso. In the event of a sudden deceleration, the reels lock automatically to protect the occupants. It is recommended that the seat belts be stowed in the latched position when not in use.

Front Seat Inflatable Restraints

An inflatable shoulder harness is integral to each front seat harness. The electronic module assembly, mounted below the cabin floor, contains a crash sensor, battery, and related circuitry to monitor the deceleration rate of the airplane. In the event of a crash, the sensor evaluates the crash pulse and sends a signal to an inflator assembly mounted to the aft seat frame. This signal releases the gas in the inflator and rapidly inflates the airbag within the shoulder harness cover. After airbag deployment, the airbag deflates to enable the pilot/co-pilot to egress the airplane without obstruction.

The crash sensor's predetermined deployment threshold does not allow inadvertent deployment during normal operations, such as hard landings, strikes on the seat, or random vibration.

To Use Restraints

• CAUTION •

No slack may exist between the occupant's shoulder and restraint harness shoulder strap.

Stow the seat belts in the latched position when not in use.

1. Slip arms behind the harness so that the harness extends over shoulders.
2. Hold the buckle and firmly insert the link.
3. Grasp the seat belt tabs outboard of the link and buckle and pull to tighten. Buckle should be centered over hips for maximum comfort and safety.
4. Restraint harnesses should fit snug against the shoulder with the lap buckle centered and tightened around the hips.

To Release Restraints

1. Grasp the top of the buckle opposite the link and pull outward. The link will slip free of buckle.
2. Slip arms from behind the harness.

Child Restraint System

To Install Child Seat (Serials w/ 2+1 Rear Seat)

The aircraft is equipped with provisions for installing two LATCH compliant child seats in the outboard rear seat positions, OR one non-LATCH compliant seat in the center rear seat position.

Lower anchors for the LATCH compliant seats are located in the outboard seat positions. The non-LATCH compliant seat must be installed using the center seat belt. Three top tether anchors for the child seats are located on the rear bulkhead.

1. Fasten lower seat attachments to bench seat:
 - a LATCH Compliant Outboard Seat: Fasten lower seat attachment to the outboard anchors in the bench seat.
 - b Non-LATCH Compliant Center Seat: Using the center seat belt, fasten lower seat attachments to the bench seat as described by the manufacturer's instructions.
2. Locate top tether pass-through - a narrow slit in the seat back upholstery - near the top, outboard section of the seat back.

• CAUTION •

Do not route child seat top tether over or around seat back. The top tether must be routed through the seat back pass-through for the child seat to function properly.

3. Route child seat's top tether through the seat back pass-through.
4. Fasten top tether to rear bulkhead anchor.
5. Firmly tension the child seat straps according to the manufacturer's instructions.

To Install Child Seat (Serials w/ Observer's Seat)

The aircraft is equipped with provisions for installing a single LATCH compliant child seat in the Observer's seat.

Lower anchors for the LATCH compliant seat is located in the outboard seat position. A top tether anchor for the child seat is located on the rear bulkhead.

1. Fasten lower seat attachment to the outboard anchors in the Observer's seat.
2. Locate top tether pass-through - a narrow slit in the seat back upholstery - near the top, outboard section of the seat back.

• CAUTION •

Do not route child seat top tether over or around seat back. The top tether must be routed through the seat back pass-through for the child seat to function properly.

3. Route child seat's top tether through the seat back pass-through.
4. Fasten top tether to rear bulkhead anchor.
5. Firmly tension the child seat straps according to the manufacturer's instructions.

Cabin Doors

Two large forward hinged doors allow crew and passengers to enter and exit the cabin. The door handles engage latching pins in the door frame receptacles at the upper aft and lower aft door perimeter. Gas charged struts provide assistance in opening the doors and hold the doors open against gusts. Front seat armrests are integrated with the doors. A key lock in each door provides security. The cabin door keys also fit the baggage compartment door lock. Separate keys are provided for the fuel caps.

Key Fob

Serials 2220, 2339 thru 2900 w/ Convenience Lighting:

Remote operation of the cabin door locks is provided by a battery-powered key fob. When BAT 1 switch is turned ON, the cabin doors will automatically unlock.

Serials 8500 and subs w/ Convenience Lighting:

Remote operation of the cabin and baggage door locks is provided by a battery-powered key fob. When BAT 1 switch is turned ON, the cabin and baggage doors will automatically unlock.

All Serials w/ Convenience Lighting:

This device complies with part 15 of the FCC Rules. Operation is subject to the following two conditions:

1. This device may not cause harmful interference.
2. This device must accept any interference received, including interference that may cause undesired operation.

• NOTE •

Key fob will not actuate door locks when BAT 1 switch is ON.

Windshield and Windows

The windshield and side windows are manufactured of acrylic. Use only clean soft cloths and mild detergent to clean acrylic surfaces. Refer to Section 8, [Exterior Windshield and Windows](#) for detailed cleaning instructions.

Engine

The airplane is powered by a Lycoming Engines IO-390-C3B6, four-cylinder, normally aspirated, fuel-injected engine producing 215 HP at 2,700 RPM. The engine has a 2200-hour Time Between Overhaul (TBO), and may be eligible for an extension as defined in Lycoming Service Instruction No. 1009. Dual, conventional magnetos provide ignition. Starting performance is improved by the addition of a SlickSTART™ magneto start booster.

The engine is attached to the firewall by a four-point steel mount structure. The firewall attach points are structurally reinforced with gusset-type attachments that transfer thrust and bending loads into the fuselage shell.

Engine Controls

Engine controls are easily accessible to the pilot on a center console. They consist of a single-lever power (throttle) control and a mixture control lever. A friction control wheel, labeled FRICTION, on the right side of the console is used to adjust control lever resistance to rotation for feel and control setting stability.

Power (Throttle) Lever

The single-lever throttle control, labeled MAX-POWER-IDLE, on the console adjusts the engine throttle setting in addition to automatically adjusting propeller speed. The lever is mechanically linked by cables to the air throttle body on the fuel servo and to the propeller governor. Moving the lever towards MAX opens the air throttle butterfly and increases the pressure differential across the air diaphragm. This change in position of the diaphragm opens the servo valve increasing the volume of fuel delivered to the engine. A separate cable to the propeller governor adjusts the governor oil pressure to increase propeller pitch to maintain engine RPM. The system is set to command 2500 RPM from idle through the cruise power setting range and 2700 RPM at full power.

Mixture Control

The mixture control lever, labeled RICH MIXTURE CUTOFF, on the console allows the pilot to manually lean the mixture for a specific power setting or fuel consumption. The mixture control lever is mechanically linked to a sliding valve inside the fuel servo. The pressure regulator within the servo functions to maintain a differential pressure across the fuel metering jet in proportion to the volume of airflow. The mixture control allows the pilot to effectively change the size of the metering jet. Moving the lever forward (toward RICH) allows the servo to meter the greatest amount of fuel based on the volume of airflow. Moving the lever aft (toward CUTOFF) reduces the size of the metering valve, leaning the fuel-to-air mixture. The full aft position (CUTOFF) closes this valve, which drops the fuel pressure in the flow divider to zero, causing it to close and shut down the engine.

Alternate Air Control

An Alternate Induction Air Control knob, labeled ALT AIR – PULL, is installed on the left console near the pilot's right knee. To operate the control, depress the center lock button, pull the knob to the open position, and then release the lock button. Pulling the knob opens the alternate air induction door on the engine induction air manifold, bypasses the air filter, and allows warm unfiltered air to enter the engine. Alternate induction air should be used if blocking of the normal air source is suspected. Operation using alternate induction air should be minimized and the cause of filter blocking corrected as soon as practical.

Engine Indicating

Engine information is displayed as analog-style gauges, bar graphs, and text on the MFD's ENGINE page. When the ENGINE page is not active or in the case of an electronic display failure (backup mode), all essential engine information is displayed along the LH edge of the display. Engine data is acquired by the Engine Airframe Unit which transmits the data to the Engine Indicating System for display as described in the following pages.

• NOTE •

A "Red X" through any electronic display field indicates the field is not receiving valid data and is considered inoperative.

Engine System Annunciations

Engine system health, caution, and warning messages are displayed in color-coded text in the Crew Alerting System (CAS) window located to the right of the Altimeter and Vertical Speed Indicator. In combination with a CAS alert, the affected engine parameter displayed on the ENGINE page changes to the corresponding color of CAS alert and the annunciation system issues an audio alert.

• NOTE •

For specific pilot actions in response to Engine System Annunciations, refer to Section 3 - Emergency Procedures, [Engine System Emergencies](#), and Section 3A - Abnormal Procedures, [Engine System](#).

For additional information on Engine Instrument Markings and Annunciations, refer to [Section 2: Limitations](#).

For additional information on the System Annunciations And Alerts, refer to the [Perspective+ Integrated Avionics System](#) description in this section.

Figure 7-7: Engine Controls and Indicating

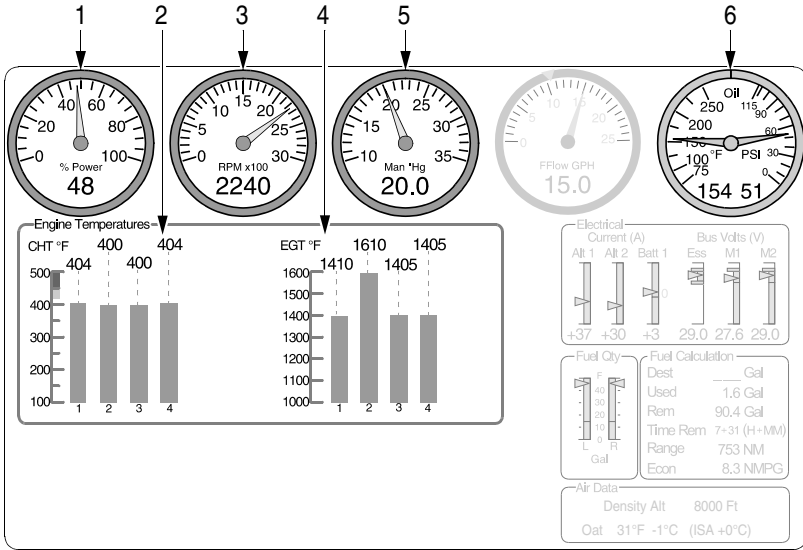

Engine Instruments

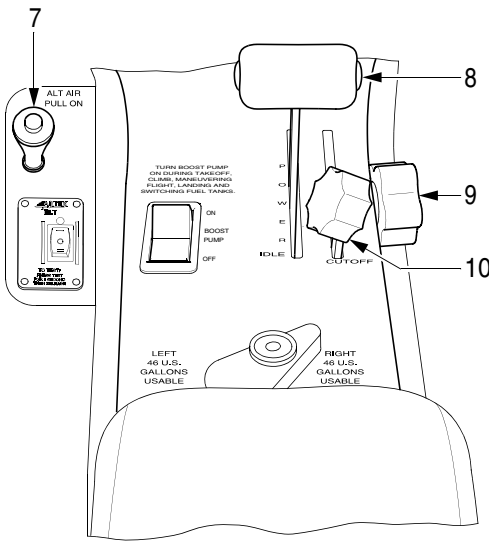

- LEGEND**
1. Percent Power
 2. CHT
 3. Tachometer
 4. EGT
 5. Manifold Pressure
 6. Oil Temperature and Pressure
 7. Alternate Air Control
 8. Power Lever
 9. Friction Control
 10. Mixture Control

Engine Controls

SR20_FM07_5394

Tachometer

Engine speed (RPM) is shown in the upper mid-left corner of the ENGINE page as both a simulated tachometer and as a digital value. The tachometer pointer sweeps a scale range from 0 to 3000 RPM in 100 RPM increments. The digital RPM value is displayed in increments of 10 RPM in white numerals below the gauge.

The tachometer receives a speed signal from a magnetic pickup sensor on the right hand magneto from the Engine Indicating System via the Engine Airframe Unit.

Exhaust Gas Temperature (EGT)

Exhaust gas temperatures for all four cylinders are displayed in the Engine Temperature block of the ENGINE page as vertical bars. The EGT graph is marked from 1000 °F to 1600 °F in 100 °F increments. The digital EGT value of the cylinder is displayed above the bar in white numerals. A sensor in the exhaust pipe of each cylinder measures exhaust gas temperature and provides a voltage signal to the Engine Airframe Unit which processes and transmits the data to the Engine Indicating System.

Cylinder Head Temperature (CHT)

Cylinder head temperatures for all four cylinders are displayed in the Engine Temperature block of the ENGINE page as vertical bars. The CHT graph is marked from 100 °F to 500 °F in 100 °F increments. The digital CHT value of the cylinder is displayed above the bar in white numerals.

A sensor in each cylinder head measures cylinder head temperature and provides a voltage signal to the Engine Airframe Unit which processes and transmits the data to the Engine Indicating System.

Oil Temperature

Oil temperature is shown in the upper right corner of the ENGINE page, opposite the oil pressure scale, as both a simulated temperature gauge and as a digital value. The gauge pointer sweeps a scale range from 75 °F to 250 °F in 50 °F increments. The digital temperature value is displayed in white numerals below the gauge.

The oil temperature sensor is mounted on the rear engine case and provides a signal to the Engine Airframe Unit that is processed and transmitted to the Engine Indicating System for display.

Oil Pressure

Oil Pressure is shown in the upper right corner of the ENGINE page, opposite the oil temperature scale, as both a simulated pressure gauge and as a digital value. The gauge pointer sweeps a scale range from 0 to 115 PSI in 10 PSI increments. The digital pressure value is displayed in white numerals below the gauge.

The oil pressure sensor is mounted on the rear engine case and provides a signal to the Engine Airframe Unit that is processed and transmitted to the Engine Indicating System for display.

Manifold Pressure Gauge

Manifold pressure is shown in the upper center portion of the ENGINE page as both a simulated pressure gauge and as a digital value. The gauge pointer sweeps a scale range from 10 to 35 inches Hg in 1 inch Hg increments. The digital MAP value is displayed in white numerals below the gauge. The manifold pressure sensor is mounted on the bottom of the induction air manifold near the throttle body and provides a signal to the Engine Airframe Unit that is processed and transmitted to the Engine Indicating System for display.

Percent Power Gauge

Percent power is shown in the upper left corner of the ENGINE page as both a simulated gauge and as a digital value. The percent power gauge sweeps a scale marked from 0 to 100 percent in 5 percent increments. The digital percent power value is displayed in white numerals below the gauge. The display units calculate the percentage of maximum engine power produced by the engine based on an algorithm employing manifold pressure, outside air temperature, pressure altitude, engine speed, and fuel flow.

Engine Lubrication System

The engine is provided with a wet-sump, high-pressure oil system for engine lubrication and cooling. Oil for engine lubrication is drawn from a seven-quart capacity sump through an oil suction strainer screen, through the remotely mounted oil cooler, and then directed to a full flow oil filter. The oil cooler is equipped with a pressure relief and temperature control valve set to bypass oil if the temperature is below 170 °F or the pressure drop is greater than 18 psi. Bypass or cooled oil is then directed through a pressure relief valve, and then through oil galleries to the engine rotating parts and piston inner domes. Oil is also directed to the propeller governor to regulate propeller pitch. The complete oil system is contained in the engine. An oil filler cap and dipstick are located at the right rear of the engine. The filler cap and dipstick are accessed through a door on the top right side of the engine cowling.

Ignition and Starter System

Two engine-driven magnetos and two spark plugs in each cylinder provide engine fuel ignition. The right magneto fires the lower right and upper left spark plugs, and the left magneto fires the lower left and upper right spark plugs. Normal operation is conducted with both magnetos (switch in BOTH position), as more complete burning of the fuel-air mixture occurs with dual ignition, and two magnetos provide redundancy. A rotary-type key switch, located on the instrument panel, controls ignition and starter operation. The switch is labeled OFF-R-LBOTH-START. In the OFF position, the starter is electrically isolated, the magnetos are grounded and will not operate. The R and L positions are used for individual magneto checks and for single magneto operation when required.

The ignition and starter system includes SlickSTART™, which changes the ignition timing and adds energy to the spark to aid in starting. When the battery master switch is ON, rotating the switch to the spring loaded START position energizes the starter and SlickSTART™, and activates both magnetos. The switch automatically returns to the BOTH position when released, and SlickSTART™ is deactivated.

28 VDC for Starter operation is supplied through the 2-amp STARTER circuit breaker on NON-ESSENTIAL BUS.

Air Induction System

Induction air enters the engine compartment through the two inlets in the forward cowling. The air passes through a paper induction filter, through the throttle butterfly, into the four-tube engine manifold, and finally through the cylinder intake ports into the combustion chambers. Should the dry induction filter become clogged, a pilot controlled alternate induction air door can be opened, allowing engine operation to continue. For additional information on the Alternate Air Control, refer to Engine Controls - [Alternate Air Control](#) description in this section.

Engine Exhaust

Engine exhaust gases are routed through an exhaust system. After leaving the cylinders, exhaust gases are routed through the exhaust manifold to a single muffler located on the left side of the engine compartment, then overboard through exhaust pipes exiting through the lower cowling. A muff type heat exchanger, located around the muffler, provides cabin heat.

Engine Fuel Injection

The multi-nozzle, continuous-flow fuel injection system supplies fuel for engine operation. An engine driven fuel pump draws fuel from the selected wing tank and passes it to the fuel servo, where fuel is proportioned in response to the pilot-operated mixture control lever position. The fuel servo adjusts fuel flow in response to the pilot-controlled Power Lever position. From the fuel servo, fuel is directed to the fuel injector manifold and then to the individual injector nozzles. The system meters fuel flow in proportion to engine RPM, mixture setting, and throttle angle. Manual mixture control and idle cut-off are provided. An electric fuel pump provides fuel pressure boost when needed.

Engine Cooling

Engine cooling is accomplished by discharging heat to the oil and then to the air passing through the oil cooler, and by discharging heat directly to the air flowing past the engine. Cooling air enters the engine compartment through the two inlets in the cowling. Composite baffles direct the incoming air to the engine and over the engine cylinder cooling fins where the heat transfer takes place. The heated air exits the engine compartment through two vents in the aft portion of the cowling. No movable cowl flaps are used.

Propeller

The airplane is equipped with a constant-speed, aluminum-alloy propeller with a governor. The airplane is available with the standard, metal, three-blade (74" diameter) propeller or an optional, composite three-blade (74" diameter) propeller.

The propeller governor automatically adjusts propeller pitch to regulate propeller and engine RPM. The propeller governor senses engine speed by means of flyweights and senses throttle setting through a cable connected to the power (throttle) control lever in the cockpit. The propeller governor boosts oil pressure in order to regulate propeller pitch position. Moving the throttle lever forward causes the governor to meter less high-pressure oil to the propeller hub allowing centrifugal force acting on the blades to lower the propeller pitch for higher RPM operation. Reducing the power (throttle) lever position causes the governor to meter more high-pressure oil to the propeller hub forcing the blades to a higher pitch, lower RPM, position. During stabilized flight, the governor automatically adjusts propeller pitch in order to maintain an RPM setting (throttle position). Any change in airspeed or load on the propeller results in a change in propeller pitch.

Fuel System

A 56-gallon usable wet-wing fuel storage system provides fuel for engine operation. The system consists of a 29.3-gallon capacity (28 gallon usable) vented integral fuel tank and a fuel collector/sump in each wing, a three position selector valve, an electric fuel pump, and an engine-driven fuel pump. Fuel is gravity fed from each tank to the associated collector sumps where the engine-driven fuel pump draws fuel through a filter and selector valve to pressure feed the engine fuel injection system. The electric fuel pump is provided for engine priming and as an emergency backup for the engine-driven fuel pump.

Each integral wing fuel tank has a filler cap in the upper surface of each wing for fuel servicing. Access panels in the lower surface of each wing allow access to the associated wet compartment (tank) for inspection and maintenance. Float-type fuel quantity sensors in each wing tank supply fuel level information to the fuel quantity gauges. Positive pressure in the tank is maintained through a vent line from each wing tank. Fuel, from each wing tank, gravity feeds through strainers and a flapper valve to the associated collector tank in each wing. Each collector tank/sump incorporates a flush mounted fuel drain and a vent to the associated fuel tank.

The engine-driven fuel pump pulls filtered fuel from the two collector tanks through a three-position (LEFT-RIGHT-OFF) selector valve. The selector valve allows tank selection. From the fuel pump, the fuel is metered to a flow divider, and delivered to the individual cylinders.

A dual-reading fuel quantity gauge is located in plain view of the pilot.

An analog electronic fuel quantity gauge is located on the Engine Strip along the left edge of the MFD and in the Fuel Qty block on the MFD's Engine page.

Fuel shutoff and tank selection is positioned nearby for easy access.

Fuel system venting is essential to system operation. Blockage of the system will result in decreasing fuel flow and eventual engine fuel starvation and stoppage. Venting is accomplished independently from each tank by a vent line leading to a NACA-type vent mounted in an access panel underneath the wing near each wing tip.

The airplane may be serviced to a reduced capacity to permit heavier cabin loadings. This is accomplished by filling each tank to a tab visible below the fuel filler, giving a reduced fuel load of 13.0 gallons usable in each tank (26 gallons total usable in all flight conditions).

Drain valves at the system low points allow draining the system for maintenance and for examination of fuel in the system for contamination and grade. The fuel must be sampled prior to each flight. A sampler cup is provided to drain a small amount of fuel from the wing tank drains, the collector tank drains, and the gascolator drain. If takeoff weight limitations for the next flight permit, the fuel tanks should be filled after each flight to prevent condensation.

Fuel Selector Valve

A fuel selector valve, located at the rear of the center console, provides the following functions:

- LEFT Allows fuel to flow from the left tank
- RIGHT Allows fuel to flow from the right tank
- OFF Cuts off fuel flow from both tanks

The valve is arranged so that to feed off a particular tank, the valve should be pointed to the fuel indicator for that tank. To select RIGHT or LEFT, rotate the selector to the desired position. To select Off, first raise the fuel selector knob release and then rotate the knob to OFF.

Fuel Pump Operation

Fuel pump operation is controlled through the Boost Pump switch located adjacent to the fuel selector valve. A single-speed emergency fuel pump allows the fuel pressure to rapidly achieve proper starting pressure. Selecting ON energizes the fuel pump to deliver a continuous 23 psi boost to the fuel flow for priming, emergency backup, and vapor suppression in a hot fuel condition.

The fuel pump operates on 28 VDC supplied through the 5-amp FUEL PUMP circuit breaker on MAIN BUS 2.

Figure 7-8: Fuel System Schematic

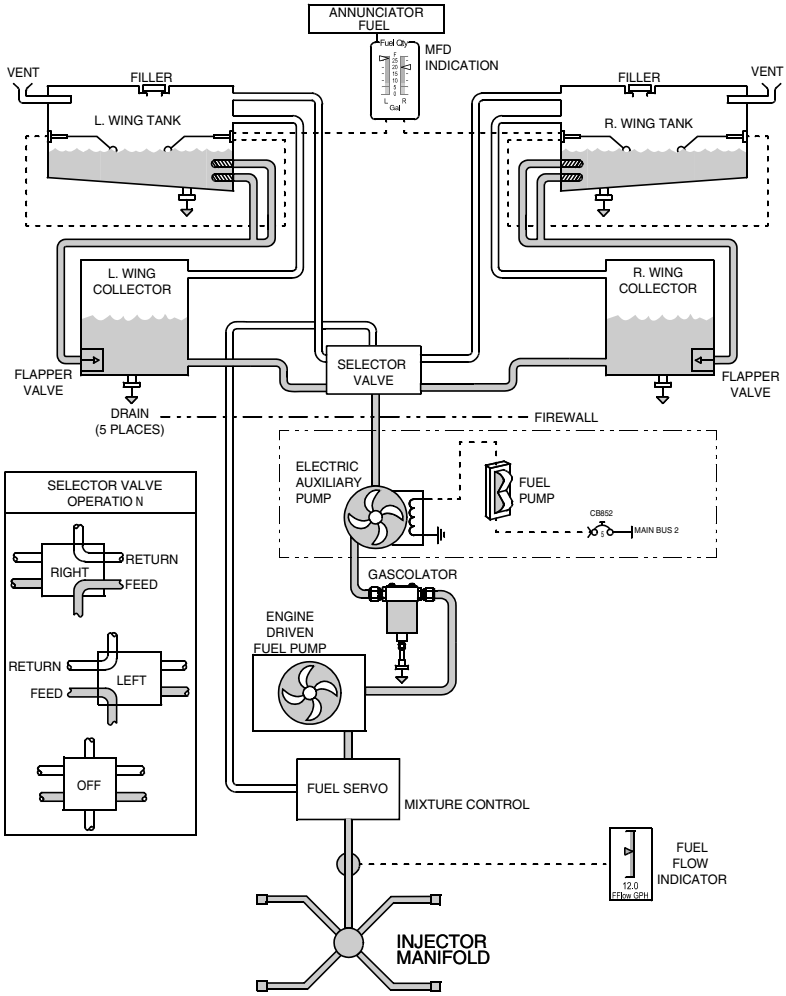

SR20_FM07_5373

Fuel Indicating

Fuel quantity is measured by float-type quantity sensors installed in each fuel tank and displayed on the Fuel Quantity Gauge.

• CAUTION •

When the fuel tanks are 1/4 full or less, prolonged uncoordinated flight such as slips or skids can uncover the fuel tank outlets. Therefore, if operating with one fuel tank dry or if operating on LEFT or RIGHT tank when 1/4 full or less, do not allow the airplane to remain in uncoordinated flight for periods in excess of 30 seconds.

• NOTE •

A “Red X” through any electronic display field indicates the field is not receiving valid data and is considered inoperative.

Fuel Quantity Gauge

A dual reading fuel quantity gauge is displayed on the Engine Strip along the left edge of the MFD and in the Fuel Qty block of the ENGINE page. In the case of an electronic display failure (backup mode), all essential fuel information is displayed on the Engine Strip along the left edge of the PFD. The LEFT pointer indicates left tank fuel quantity and sweeps a vertical bar scale marked from 0 to 28 U.S. gallons in 5-gallon increments. The RIGHT pointer sweeps an identical scale for the right tank. Each scale is marked with a yellow band from 0 to 10 U.S. gallons and a green band from 10 to 28 U.S. gallons. The indicators are calibrated to read 0 gallons when no usable fuel remains.

Fuel quantity is measured by a float type quantity sensors installed in the fuel tanks. Fluid quantity information is sent to the Engine Airframe Unit, processed, and transmitted to the analog electronic Fuel Quantity Gauge and CAS window for display.

Fuel Flow

Fuel Flow is shown in the upper mid left corner of the Engine Strip as both an analog electronic gauge and as a digital value. The gauge pointer sweeps a scale range from 0 to 30 Gallons Per Hour (GPH). The fuel flow value is displayed in white numerals below the gauge. Fuel flow is measured by a transducer located on top of the engine, next to the aft baffle, between the fuel servo and the distribution block.

The fuel flow signal is sent to the Engine Airframe Unit, processed, and transmitted to the Engine Indicating System for display.

Target Fuel Flow is a cyan pointer placed on the fuel gauge to aid in cruise power leaning. The cyan pointer becomes available on the fuel flow gauge at engine power settings below 75%.

• NOTE •

Target Fuel Flow is removed from gauge at low power settings (intended for cruise, not descent leaning guidance).

Fuel Totalizer and Calculated Information

Fuel totalizer calculations are located in the lower right section of the ENGINE page and are separate and independent of the fuel quantity gauge and float sensor system. The fuel totalizer monitors fuel flow and calculates fuel-to-destination, fuel used, fuel remaining, time remaining, fuel range, and nautical miles per gallon. Upon system startup, the fuel totalizer initial fuel screen appears and prompts the user to enter the total fuel on board at start. The option to enter the number of gallons added since last fuel fill and the ability to set fuel to “Full” or to “Tabs” buttons is also available.

Fuel System Annunciations

Fuel system health, caution, and warning messages are displayed in color-coded text in the Crew Alerting System (CAS) window located to the right of the Altimeter and Vertical Speed Indicator. In combination with a CAS alert, the affected fuel parameter displayed on the ENGINE page changes to the corresponding color of CAS alert and the annunciation system issues an audio alert.

FUEL LOW: Low Fuel quantity.

- Red warning messages are generated for left and/or right fuel tank when sensed quantity in indicated tank is less than 1 gallon.
- A red Warning message is generated when the fuel totalizer or total sensed quantity is less than 7 gallons.
- An amber Caution message is generated when the fuel totalizer or total sensed quantity is less than or equal to 10 gallons.

FUEL IMBALANCE: Imbalanced between Left and Right Tanks.

- A white Advisory message is generated when the imbalance between tanks is greater than 5.5 gallons.
- An amber Caution message is generated when the imbalance between tanks is greater than 7.5 gallons.
- A red Warning message is generated when the imbalance between tanks is greater than 9.5 gallons.

• NOTE •

For specific pilot actions in response to Fuel System Annunciations, refer to Section 3 - Emergency Procedures, [Fuel System Emergencies](#), and Section 3A - Abnormal Procedures, [Fuel System](#).

For additional information on Engine Instrument Markings and Annunciations, refer to [Section 2: Limitations](#).

For additional information on the System Annunciations And Alerts, refer to the [Perspective+ Integrated Avionics System](#) description in this section.

Figure 7-9: Fuel System Controls and Indicating

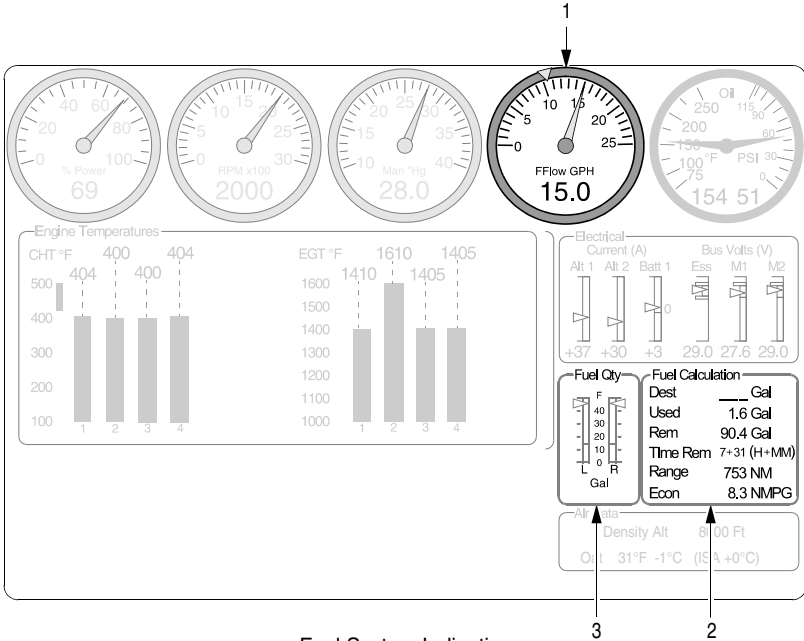

Fuel System Indication

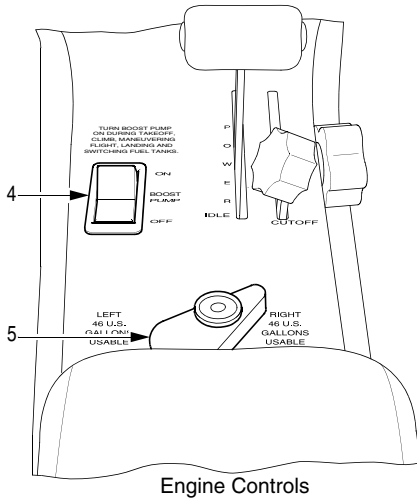

LEGEND

1. Fuel Flow Gauge
2. Fuel Calculations:
 - Fuel At Destination (Totalizer)
 - Fuel Used (Totalizer)
 - Fuel Remaining (Totalizer)
 - Time Remaining (Totalizer)
 - Fuel Range (Totalizer)
 - Nautical Miles Per Gallon (Totalizer)
3. Fuel Quantity Gauge (Float Sensor)
4. Fuel Pump Switch
5. Fuel Selector Valve

SR20_FM07_5395

Mixture Management

The mixture control needs to be carefully monitored and managed during all phases of flight to avoid damage to the engine or a possible loss of power.

After engine start, and during taxiing operations, lean the mixture until maximum engine RPM is attained to prevent possible spark plug fouling and ensure smooth engine operation.

Takeoff and climb fuel flows need to be set appropriately. Fuel flow at full power should be at the top of the green arc on the fuel flow gauge for rated take-off, climb and maximum cruise powers (above approximately 75%). During take-off from a high elevation airport or during climb, roughness or loss of power can occur from over-richness. In such a case, adjust the mixture control only enough for smooth operation - not for economy. Monitor instruments for temperature rise.

During climb, it is necessary to lean the mixture to ensure engine smoothness and optimal power. Rough operation due to over-rich fuel/air mixture is most likely to be encountered at density altitudes above 5,000 feet (1524 meters). Fuel flow at full power should be at the top of the green arc on the fuel flow gauge. See maximum power fuel flow and other information published in this POH. Refer to [Section 4: Normal Procedures](#). EGT's should generally be at least 1300 °F at full power. If CHTs or oil temps become higher than desired, using a slightly richer fuel flow will aid in engine cooling.

During cruise flight, the throttle should be set for 85% power or less when operating the engine at best power and 75% power at best economy mixture settings. During best power operations the mixture should be set for 100 °F rich of peak EGT. During best economy operations the mixture should be set between peak and 50 °F lean of peak EGT, depending on ambient conditions. If lean misfire conditions are encountered, the mixture should be enriched until the condition resolves. Alternatively, the mixture can be set to the cyan target FF mark that is displayed on the FF gauge.

If a cruise power descent is used, it is necessary to richen the mixture to maintain EGT's at approximately 1300 - 1500 °F during descent. If a reduced power descent is used, it is still necessary to richen the mixture to prevent loss of power or an overly lean condition when power is added.

During approach and landing, the mixture should be set to the position that will result in obtaining the top of the green arc on the fuel flow gauge when the throttle is advanced to wide open. This mixture position is approximately equivalent to the cyan target when at reduced power settings.

Electrical System

The airplane is equipped with a two-alternator, two-battery, 28-volt direct current (VDC) electrical system designed to reduce the risk of electrical system faults. The system provides uninterrupted power for avionics, flight instrumentation, lighting, and other electrically operated and controlled systems during normal operation.

Power Generation

Primary power for the airplane is supplied by a 28-VDC, negative-ground electrical system. The electrical power generation system consists of two alternators controlled by a Master Control Unit (MCU) mounted on the left side of the firewall and two batteries for starting and electrical power storage.

Alternator 1 (ALT 1) is a belt-driven, internally rectified, 100-amp alternator mounted on the right front of the engine. Alternator 2 (ALT 2) is a belt-driven, internally rectified, 70-amp alternator mounted on the front left of the engine. ALT 1 is regulated to 27.7 volts and ALT 2 is regulated to 28.7 volts. Both alternators are not self-exciting and require battery voltage for field excitation in order to start up.

Storage

Battery 1 (BAT 1) is an aviation grade 12-cell, lead-acid, 24-volt, 11-amp-hour battery mounted on the right firewall. BAT 1 is charged from the Main Distribution Bus 1 in the MCU.

Battery 2 (BAT 2) is composed of two 12-volt, 7-amp-hour, sealed, lead-acid batteries connected in series to provide 24 volts. Both BAT 2 units are located in a vented, acid-resistant container mounted behind the aft cabin bulkhead (FS 222) below the parachute canister. BAT 2 is charged from the circuit breaker panel ESS BUS 1.

Figure 7-10: Electrical System Schematic

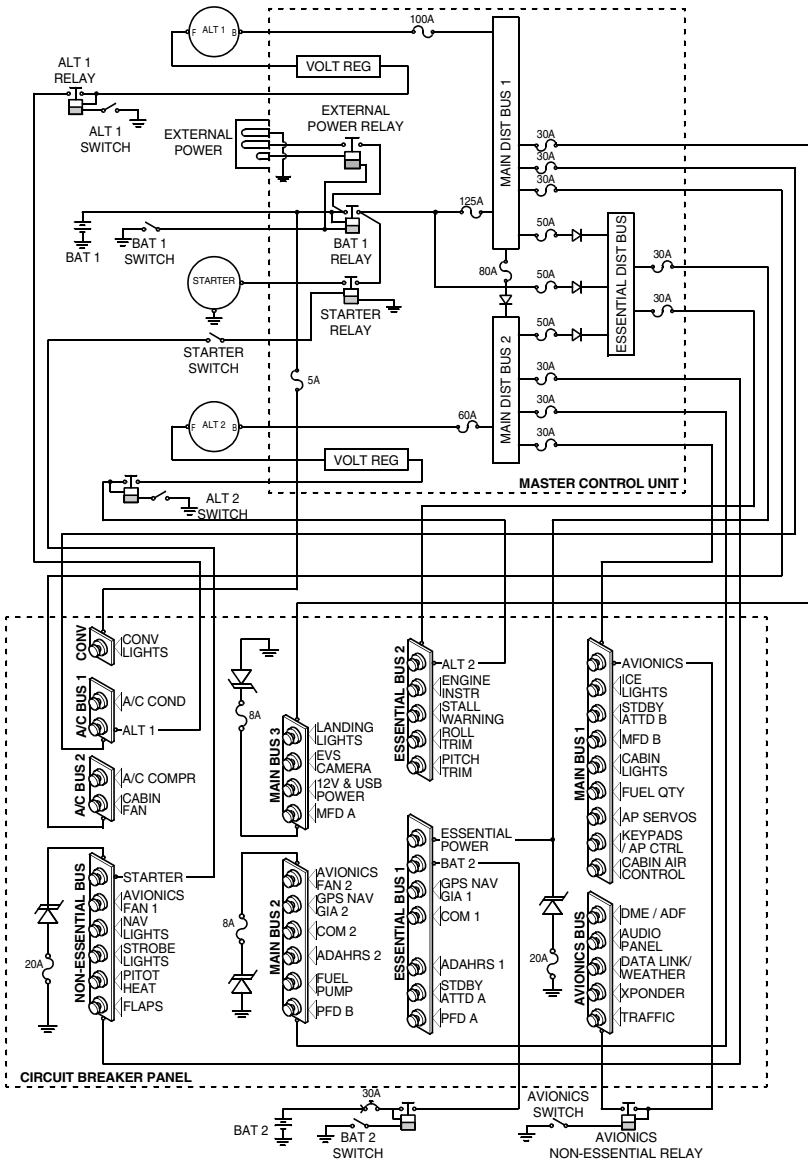

SR20_FM07_5380

Power Distribution

Power is supplied to the airplane circuits through three distribution buses contained in the MCU: Main Distribution Bus 1, Main Distribution Bus 2, and the Essential Distribution Bus. The three distribution buses power the associated buses on the circuit breaker panel.

Master Control Unit

The Master Control Unit (MCU) is located on the left firewall. The MCU controls ALT 1, ALT 2, starter, external power, and power generation functions. In addition to ALT 1 and ALT 2 voltage regulation, the MCU also provides external power reverse polarity protection, alternator overvoltage protection, as well as electrical system health annunciations to the Integrated Avionics System. Power is distributed to the airplane circuit panel buses through Main and Essential buses in the MCU. The Main distribution buses are interconnected by an 80-amp fuse and a diode. The diode prevents ALT 2 from feeding the Main Distribution Bus 1. Additionally, since ALT 2 Bus voltage is slightly higher than ALT 1 voltage, bus separation is further assured.

Essential Distribution Bus

The Essential Distribution Bus is fed by both Main Distribution Bus 1 and Main Distribution Bus 2 in the MCU through two 50-amp fuses. The Essential Bus powers two circuit breaker buses through 30-amp fuses located in the MCU:

- ESS BUS 1,
- ESS BUS 2.

Main Distribution Bus 1

The output from ALT 1 is connected to the Main Distribution Bus 1 in the MCU through a 100-amp fuse. Main Distribution Bus 1 directly powers three circuit breaker buses through 30-amp fuses located in the MCU:

- A/C BUS 1,
- A/C BUS 2,
- MAIN BUS 3.

Main Distribution Bus 2

The output from ALT 2 is connected to the Main Distribution Bus 2 in the MCU through an 80-amp fuse. Main Distribution Bus 2 powers three circuit breaker buses through 30-amp fuses located in the MCU:

- NON ESS BUS,
- MAIN BUS 1,
- MAIN BUS 2.

Constant Power Bus (CONV)

The Constant Power Bus (CONV) is fed by BAT 1 in the MCU through one 5-amp fuse located on top of the MCU.

Electrical System Protection

Circuit Breakers, Fuses and Voltage Suppressors

Individual electrical circuits connected to the Main, Essential, and Non-Essential Buses in the airplane are protected by re-settable circuit breakers mounted in the circuit breaker panel on the left side of the center console. Loads on circuit breaker panel buses are shed by pulling the individual circuit breakers.

Transient Voltage Suppressors

Transient Voltage Suppressors (TVS) are installed in key areas of the electrical system to protect the system from lightning strikes. During lightning strikes, enormous energy spikes can be induced within the airplane electrical system. In the absence of any transient protection, this unwanted energy would typically be dissipated in the form of high-voltage discharge across the avionics and electrical systems of the airplane. By adding a high power TVS at key power entry points on the electrical buses, unwanted energy from electrical transients is allowed to dissipate through a semi-conducting pathway to ground.

• CAUTION •

If smoke and/or fumes are detected in the cabin and it is suspected that this event was caused by a TVS failure, the operator should confirm that there is no fire and perform the [Smoke and Fume Elimination](#) Checklist.

Essential Buses

The circuit breaker panel ESS BUS 1 and ESS BUS 2 are powered directly by ALT 1 and ALT 2 from the MCU Essential Distribution Bus through 30-amp fuses inside the MCU and also by BAT 2 through the 20-amp BAT 2 circuit breaker.

In the event of ALT 1 or ALT 2 failure, the Essential Buses in the circuit breaker panel will be powered by the remaining alternator through the Main Distribution Bus 1 or Main Distribution Bus 2 in the MCU. In the case of both alternators failing, BAT 1 is connected directly to the Essential Distribution Bus in the MCU and will power ESS BUS 1 and ESS BUS 2. In the event of both alternators and BAT 1 failing, BAT 2 is connected directly to ESS BUS 1.

Main Buses

The circuit breaker panel MAIN BUS 1 and MAIN BUS 2 are powered by ALT 2 from the MCU Main Distribution Bus 2 and - in the event of ALT 2 failure - by ALT 1 and BAT 1 from the Main Distribution Bus 2 via the diode interconnecting the MCU distribution buses through 30-amp fuses inside the MCU.

The 10-amp AVIONICS circuit breaker on MAIN BUS 1, controlled through the AVIONICS master switch on the bolster switch panel, powers all loads on the AVIONICS bus.

The circuit breaker panel MAIN BUS 3 is powered by ALT 1 and BAT 1 from the MCU Main Distribution Bus 1 through a 30-amp fuse inside the MCU. In the event of ALT 1 failure, BAT 1 will power MAIN BUS 3. ALT 2 is prevented from powering MAIN BUS 3 by the isolation diode interconnecting the MCU distribution buses 1 and 2.

Non-Essential Buses

The circuit breaker panel NON ESS BUS is powered by ALT 2 from the MCU Main Distribution Bus 2 and - in the event of ALT 2 failure - by ALT 1 and BAT 1 from the Main Distribution Bus 2 via the diode interconnecting the MCU distribution buses through 30-amp fuses inside the MCU. The Avionics Non-Essential Bus is powered through the 10-amp AVIONICS circuit breaker on MAIN BUS 1 and is discussed above.

The circuit breaker panel A/C BUS 1 and A/C BUS 2, is powered by ALT 1 and BAT 1 from the MCU Main Distribution Bus 1 through a 30-amp fuse inside the MCU. In the event of ALT 1 failure, BAT 1 will power A/C BUS 1 and A/C BUS 2. ALT 2 is prevented from powering A/C BUS 1 and A/C BUS 2 by the isolation diode interconnecting the MCU distribution buses 1 and 2.

Electrical System Control

The rocker type electrical system MASTER switches are 'on' in the up position and 'off' in the down position. The switches, labeled BAT 2, BAT 1, ALT 1, ALT 2 are located in the bolster switch panel immediately below the instrument panel. These switches, along with the AVIONICS master switch, control all electrical power to the airplane.

Battery Switches

The BAT 1 and BAT 2 switches control the respective battery. Setting the BAT 1 switch 'on' energizes a relay connecting BAT 1 to the MCU Distribution Buses (also energizing the circuit breaker panel buses) and the open contacts of the starter relay. Setting the BAT 2 switch 'on' energizes a relay connecting BAT 2 to the circuit breaker panel ESS BUS 1. Normally, for flight operations, all master switches will be 'on'. However, the BAT 1 and BAT 2 switches can be turned 'on' separately to check equipment while on the ground. Setting only the BAT 2 switch 'on' will energize those systems connected to the circuit breaker panel's ESS BUS 1 and ESS BUS 2. If any system on the other buses is energized, a failure of the Distribution Bus interconnect isolation diode is indicated. When the BAT 1 switch is set to 'on', the remaining systems will be energized. To check or use non-essential avionics equipment or radios while on the ground, the AVIONICS master switch must also be turned on.

Alternator Switches

The ALT 1 and ALT 2 switches control field power to the respective alternator. For ALT 1 to start, the BAT 1 switch must be 'on'. Setting the ALT 1 switch 'on' energizes a relay allowing 28 VDC from the 5 amp ALT 1 circuit breaker on A/C BUS 1 to be applied to a voltage regulator for ALT 1. For ALT 2 to start, either the BAT 1 switch or the BAT 2 switch must be 'on.' Setting the ALT 2 switch 'on' energizes a relay allowing 28 VDC from the 5 amp ALT 2 circuit breaker on ESS BUS 2 to be applied to voltage regulator for ALT 2. Positioning either ALT switch to the OFF position removes the affected alternator from the electrical system.

• CAUTION •

Continued operation with the alternators switched off will reduce battery power enough to open the battery relay, remove power from the alternator field, and prevent alternator restart.

AVIONICS Master Switch

A rocker switch, labeled AVIONICS, controls electrical power from the circuit breaker panel (MAIN BUS 1) to the AVIONICS bus. The switch is located next to the ALT and BAT Master switches. Typically, the switch is used to energize or de-energize all non-essential avionics on the AVIONICS bus simultaneously. With the switch in the OFF position, no electrical power will be applied to the non-essential avionics equipment, regardless of the position of the MASTER switch or the individual equipment switches. For normal operations, the AVIONICS switch should be placed in the OFF position prior to activating the MASTER switches, starting the engine, or applying an external power source.

Ground Service Receptacle

A ground service receptacle is located just aft of the cowl on the left side of the airplane. This receptacle is installed to permit the use of an external power source for cold weather starting and maintenance procedures requiring reliable power for an extended period. The external power source must be regulated to 28 VDC. The external power control contactor is wired through the BAT 1 MASTER switch so that the BAT 1 switch must be 'on' to apply external power.

Refer to Section 8, [Ground Handling](#) for use of external power and special precautions to be followed.

Electrical Indicating

Electrical system information is displayed as bar graphs and text on the MFD's ENGINE page. When the ENGINE page is not active or in the case of an electronic display failure (backup mode), Battery 1 ampere output and Essential Bus voltage output are displayed along the LH edge of the display. Electrical data is acquired by the Engine Airframe Unit which transmits the data to the Engine Indicating System for display as described in the following pages.

• NOTE •

A "Red X" through any electronic display field indicates the field is not receiving valid data and is considered inoperative.

Electrical System Annunciations

Electrical system health, caution, and warning messages are displayed in color-coded text in the Crew Alerting System (CAS) window located to the right of the Altimeter and Vertical Speed Indicator. In combination with a CAS alert, the affected electrical parameter displayed on the ENGINE page changes to the corresponding color of CAS alert and the annunciation system issues an audio alert.

• **NOTE** •

For specific pilot actions in response to Electrical System Annunciations, refer to Section 3 - Emergency Procedures, [Electrical System Emergencies](#), and Section 3A - Abnormal Procedures, [Electrical System](#).

For additional information on Engine Instrument Markings and Annunciations, refer to [Section 2: Limitations](#).

For additional information on the System Annunciations And Alerts, refer to the [Perspective+ Integrated Avionics System](#) description in this section.

Figure 7-12: Electrical / Lighting Controls and Indicating

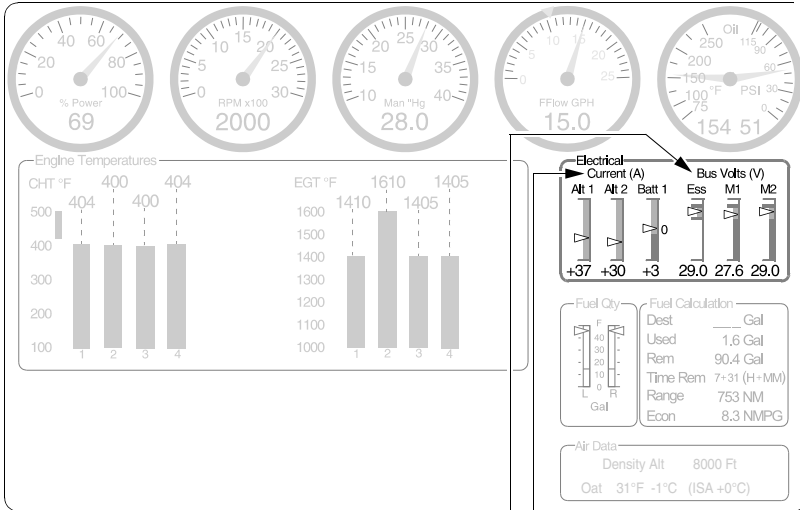

1 2

Electrical System Indication

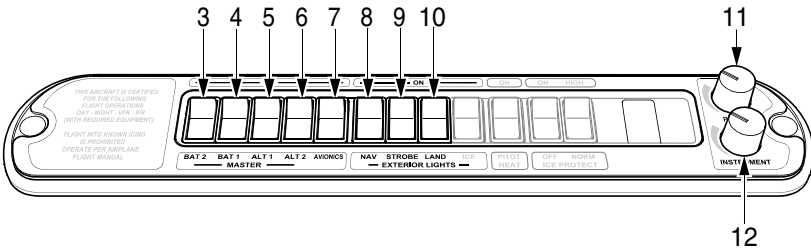

Electrical and Lighting Controls

LEGEND

- | | |
|---------------------------------|-----------------------|
| 1. Essential & Main Bus Voltage | 7. Avionics |
| 2. Alternator & Battery Current | 8. Navigation |
| 3. Battery 2 | 9. Strobe |
| 4. Battery 1 | 10. Landing Light |
| 5. Alternator 1 | 11. Panel Dimmer |
| 6. Alternator 2 | 12. Instrument Dimmer |

SR20_FM07_5385

Lighting Systems

Exterior Lighting

Refer to POH Supplement for Spectra Wing Tip Lights (p/n 11934-S56) for description of Exterior Lighting.

Interior Lighting

Interior lighting for the airplane consists of overhead lights for general cabin lighting, individual lights for the pilots and passengers, and dimmable panel floodlights. The flight instrumentation and avionics equipment lights are dimmable.

Instrument Lights

Instrument lighting for the airplane includes: Primary Flight and Multi-function Display backlighting and bezel, bolster switch panel, audio panel keys, FMS keyboard, and optionally installed GMC 705 AFCS Control Unit, incandescent lights in the standby instrument bezels, key backlighting and status lighting for the flap and Environmental Control System (ECS) control panels. Associated lighting is adjustable through the INSTRUMENT dimmer control on the instrument panel bolster. The dimmer is OFF when rotated fully counterclockwise, all systems revert to daytime lighting in this position (not full DIM).

In daytime lighting (knob OFF/full counterclockwise):

- Standby instruments, all Avionics system keypads and the bolster switch panel are unlit.
- MFD and PFD screen illumination is controlled by automatic photocell (providing full brightness in high light conditions, only slightly reduced by darkness).
- ECS and control panels are backlight and their status lights at maximum intensity.

With active dimming (knob moved clockwise), the full bright position (full clockwise) applies maximum illumination to keys and switches, to standby instruments and to status lights, but the PFD/MFD screen illumination is at a substantially reduced level (levels still appropriate for night flight). Maximum screen illumination (appropriate for daytime use) is with the dimmer OFF/full counterclockwise.

The instrument light circuits operate on 28 VDC supplied through the 5-amp CABIN LIGHTS circuit breaker on MAIN BUS.

Panel Flood Lights

A string of red LEDs mounted under the instrument panel glareshield provide flood lighting for the instrument panel. The lights are controlled through the PANEL dimmer control on the instrument panel bolster.

The panel lights operate on 28 VDC supplied through the 5-amp CABIN LIGHTS circuit breaker on MAIN BUS 1.

Reading Lights

Individual eyeball-type reading lights are installed in the headliner above each passenger position. Each light is aimed by positioning the lens in the socket and is controlled by a push-button switch located next to the light. The pilot and copilot reading lights are also dimmable through the PANEL lights control on the instrument panel bolster. The reading lights are powered by 28 VDC supplied through the 5-amp CABIN LIGHTS circuit breaker on MAIN BUS 1.

Overhead Dome Light

General cabin lighting is provided by a dome light located in the headliner at the approximate center of the cabin.

Serials w/o Convenience Lighting:

The dome light is controlled through the cabin light switch located next to the light assembly on the ceiling of the airplane.

The dome light is powered by 28 VDC supplied through the 5-amp CABIN LIGHTS circuit breaker on MAIN BUS 1.

Convenience Lighting

Serials w/ Convenience Lighting:

The convenience lighting option consists of the overhead dome light, overhead baggage compartment lights, interior footwell lights, exterior entry step lights, and a key fob.

Overhead Dome Light

General cabin lighting is provided by a dome light located in the headliner at the approximate center of the cabin.

Overhead Baggage Compartment Lights

General baggage compartment lighting is provided by lights located in the headliner.

Footwell Lights

General floor lighting is provided by footwell lights located throughout the cabin.

Entry Step Lights

Serials 2220, 2339 thru 2900:

Illumination of the entry steps is provided by lights located above each step.

Serials 8500 and subs:

Illumination of the entry steps and the surrounding area is provided by lights within the step.

All Serials:

Convenience lighting is controlled by the cabin light switch located on the ceiling of the airplane. 28 VDC for convenience lighting is supplied through the 5-amp CONV LIGHTS circuit breaker on CONV BUS.

Key Fob

Remote operation of the door locks is provided by a battery-powered key fob. Refer to [Cabin Doors](#) and [Baggage Compartment](#) descriptions in this section.

Convenience Lighting Operation

When the cabin light switch is in the ON position:

- Dome light and footwell lights will turn on.
- Entry step lights will turn on when either cabin door is opened or the doors are unlocked via the key fob and will turn off when both cabin doors are closed or the doors are locked via the key fob.
- Baggage compartment lights will turn on when baggage door is opened and will turn off when baggage door is closed.

When the cabin light switch is in the OFF position:

- Dome light, baggage compartment lights, footwell lights, and entry step lights will turn off.

When the cabin light switch is in the AUTO position:

- Dome light, footwell lights, and entry step lights will turn on when either cabin door is opened or the doors are unlocked via the key fob and will turn off when both cabin doors are closed or the doors are locked via the key fob.
- Baggage compartment lights will turn on when baggage door is opened and will turn off when baggage door is closed.

When aircraft power is turned off, all convenience lighting will turn off after several minutes of illumination.

Environmental System

• NOTE •

To facilitate faster cabin cooling, prior to engine start leave the cabin doors open for a short time to allow hot air to escape.

Standard cabin heating and ventilation is accomplished by supplying conditioned air from the heat exchanger for heating and windshield defrost and fresh outside air for ventilation. The environmental system consists of a fresh air inlet in the lower RH cowl, a heat exchanger around the RH engine exhaust muffler, an air mixing chamber, air ducting for distribution, a distribution manifold, a windshield diffuser, crew and passenger air vents, and associated plumbing, controls, actuators, wiring for system flow-selection and temperature control.

An optional 3-speed blower fan is available to supplement airflow when ram air may be inadequate such as during ground operation.

28 VDC for Environmental System Control Panel operation is supplied through the 2-amp CABIN AIR CONTROL circuit breaker on MAIN BUS 1.

The optional Blower Fan is powered by 28 VDC supplied through a 15-amp CABIN FAN circuit breaker on A/C BUS 2.

Serials w/ Optional Air Conditioning System:

The Air Conditioning System is designed to cool the cabin to desired temperature settings and maintain comfortable humidity levels. The system consists of an engine driven compressor, condenser assembly, and evaporator assembly.

28 VDC for Air Conditioner Condenser operation is supplied through the 15-amp A/C COND circuit breaker on A/C BUS 1.

28 VDC for Air Conditioner Compressor operation is supplied through the 5-amp A/C COMPR circuit breaker on A/C BUS 2.

The airplane engine must be running for the air conditioner to operate.

Figure 7-13: Standard Environmental System

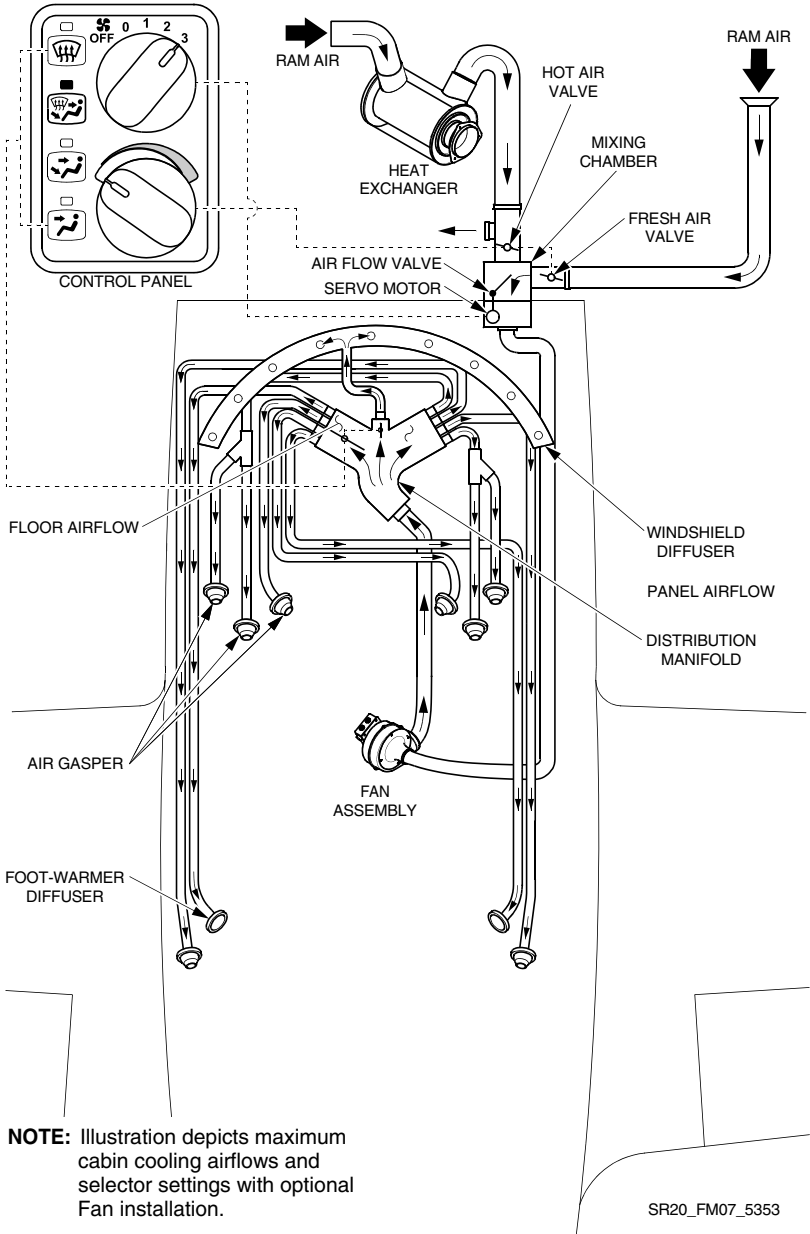
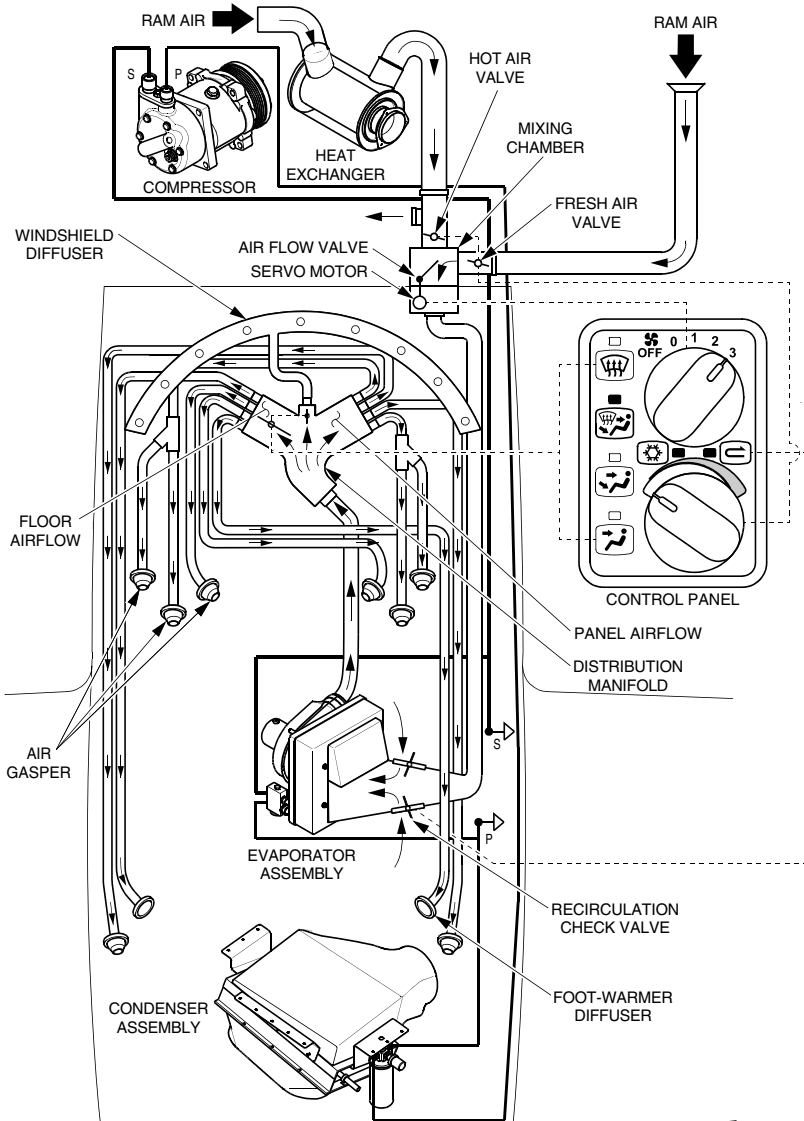

Figure 7-14: Optional Air Conditioning System



NOTE: Illustration depicts maximum cabin cooling airflows and selector settings while on ground or warm outside air temperatures.

SR20_FM07_5356

Distribution

Ventilation and cooling is provided by ducting fresh air from a NACA inlet on the RH cowl to the mixing chamber located on the lower RH portion of the firewall. Depending on operating mode and temperature selection, the air in the mixing chamber is ducted directly into the distribution system or, if in air conditioning mode (optional), is further cooled as it passes through the evaporator assembly located under the front passenger seat.

Heating is accomplished by mixing ventilation air from the fresh air inlet with heated air provided by the heat exchanger in the mixing chamber on the firewall. From the mixing chamber - which also controls airflow into the cabin compartment - the conditioned air is forced by ram air pressure or by blower fan into a distribution manifold mounted to the center, aft side of the firewall. The distribution manifold uses butterfly valves to control airflow to the floor and defrost vents. Airflow is ducted directly to all panel air vents.

Crew panel air vents are located inboard on the RH and LH bolster panels and on the outboard section of the instrument panel. The crew floor air vents are mounted to the bottom of each kick plate. The passenger panel air vents are chest high outlets mounted in the armrests integral to the LH and RH cabin wall trim panels. The passenger floor air vents are mounted to the bottom portion of the LH and RH cabin wall trim panels. The windshield diffuser, located in the glareshield assembly, directs conditioned air to the base of the windshield.

Heating

Ram air from the NACA inlet flows through the upper cowl and is ducted to the heat exchanger. The heated air is then routed to the hot air valve, mounted to the forward side of the firewall, which controls entry of hot air into the cabin distribution system. When the valve is open, the air flows into the cabin mixing chamber. When the valve is closed, the heated air exits into the engine compartment and is exhausted overboard with the engine cooling airflow. Cabin heat is regulated by controlling the volume of hot air admitted into the distribution system's air mixing chamber. The proportion of heated air to fresh air is accomplished using the temperature selector mounted on the RH instrument panel.

Cooling

Standard cabin cooling is provided by ram air admitted through the NACA inlet on the RH cowl to the fresh air valve, mounted to the forward side of the firewall. When the fresh air valve is open, the air flows into the cabin mixing chamber. When the fresh air valve is closed, the cooled air exits into the engine compartment and is exhausted overboard with the engine cooling airflow.

In Air Conditioning mode (optional), R134A refrigerant enters the engine mounted compressor as a vapor and is pressurized until the heat-laden vapor reaches a point much hotter than the outside air. The compressor then pumps the vapor to the condenser where it cools, changes to a liquid, and passes to the receiver-drier. The receiver-drier's function is to filter, remove moisture, and ensure a steady flow of liquid refrigerant into the evaporator through the expansion valve - a temperature controlled metering valve which regulates the flow of liquid refrigerant to the evaporator. Inside the evaporator, the liquid refrigerant changes state to a gas and in doing so, absorbs heat. The evaporator then absorbs the heat from the air passing over the coils and the moisture from the air condenses and is drained overboard through the belly of the airplane. From the evaporator, the refrigerant vapor returns to the compressor where the cycle is repeated. During normal air conditioning operation, ram air from the fresh air intake flows into the evaporator assembly, is cooled as it passes through the evaporator coils, and is then ducted forward to the distribution manifold.

Airflow Selection

The airflow selector on the system control panel regulates the volume of airflow allowed into the cabin distribution system. When the airflow selector is moved past the OFF position, an electro-mechanical linkage actuates a valve in the mixing chamber on the forward firewall to the full open position. The air is then distributed by either ram air or blower fan to the distribution manifold mounted to the center, aft side of the firewall. The airflow system modes are as follows: OFF (no fresh air flow), 0 (ram air), 1 (low fan), 2 (medium fan), and 3 (high fan).

Vent Selection

Air from the distribution manifold is proportioned and directed to passengers and/or the windshield by pressing the cabin vent selector buttons which electrically actuate butterfly valves at the entrances to the windshield diffuser and the cabin floor ducting.

When the Temperature Selector is in the blue "cool" zone, there is continuous airflow to the panel and armrest eyeball outlets. Each occupant can control the flow rate from 'off' to maximum by rotating the nozzle.

When the Panel selector button is pushed, both butterfly valves are closed providing maximum airflow to the instrument panel and armrest eyeball outlets.

Pressing the Panel-Foot selector button opens the cabin floor butterfly valve allowing airflow to the rear seat foot warmer diffusers and the front seat outlets mounted to the underside of each kickplate.

Selecting Panel-Foot-Windshield button opens the windshield diffuser butterfly valve which permits shared airflow to the defrosting mechanism and cabin floor outlets.

When the Windshield selector button is pushed, the cabin floor butterfly valve is closed providing maximum airflow to the windshield diffuser.

Temperature Selection

The temperature selector is electrically linked to the hot and cold air valves. Rotating the selector simultaneously opens and closes the two valves, permitting hot and cold air to mix and enter the distribution system. Rotating the selector clockwise, permits warmer air to enter the system - counterclockwise, cooler air.

On airplane with the optional Air Conditioning System installed, when the air conditioning button (snowflake) is pushed, the valve on the firewall completely closes and the air conditioner is activated. When recirculation button is pushed, the fresh air valve completely closes and cabin air is recirculated to provide for maximum air conditioning operation. When the air conditioning system is on and the temperature selector is rotated to the full cool position, recirculating mode can be activated to provide maximum cabin cooling. Air conditioning or recirculating mode is not available when the airflow fan selector is in the "0" position. Recirculating mode is not available unless the air conditioning system is operating.

Figure 7-15: Environmental System Operation

Rotating the selector controls the volume of airflow allowed into the cabin distribution system through use of an electro-mechanical linkage to a butterfly (hot air) valve in the mixing chamber on the forward firewall. When the airflow selector fan speed is moved to the 1, 2, or 3 position the electro-mechanical linkage actuates the hot air valve to the full open position and the 3-speed blower fan is turned on.

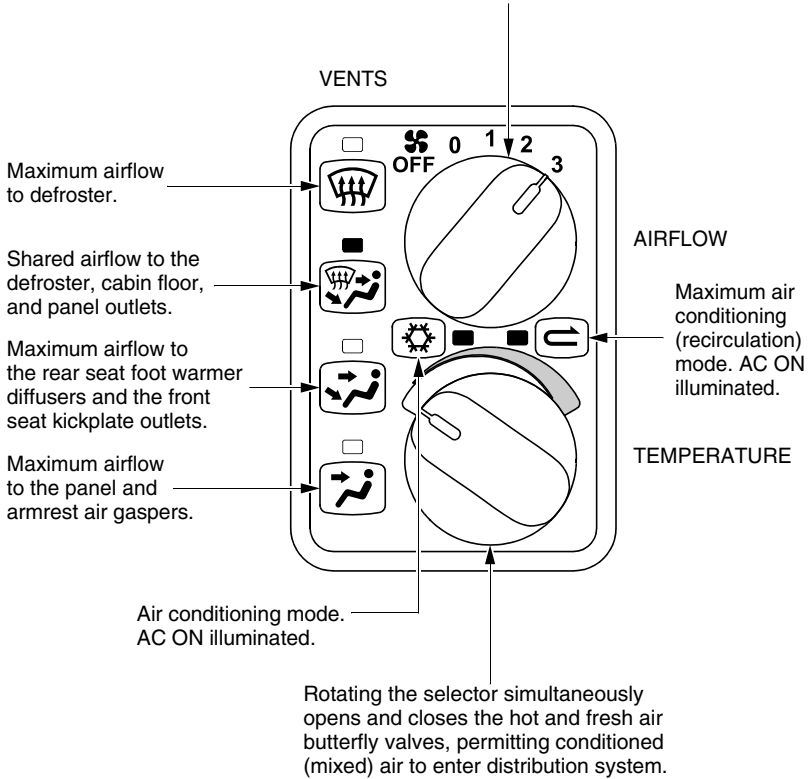

NOTE: Illustration depicts settings for Emergency Procedures Smoke and Fume Elimination.
If source of smoke and fume is firewall forward, turn Airflow Selector OFF.

SR20_FM07_5359

Stall Warning System

The airplane is equipped with an electro-pneumatic stall warning system to provide audible warning of an approach to aerodynamic stall. The system consists of an inlet in the leading edge of the right wing, a pressure switch and associated plumbing.

As the airplane approaches a stall, the low pressure on the upper surface of the wings moves forward around the leading edge of the wings. As the low pressure area passes over the stall warning inlet, a slight negative pressure is sensed by the pressure switch. The pressure switch then provides a signal to cause the warning horn to sound, the red STALL warning CAS annunciator to illuminate.

The warning sounds at approximately 5 knots above stall with full flaps and power off in wings level flight and at slightly greater margins in turning and accelerated flight.

In the event of a stall warning system malfunction (e.g. ice accretion or other contamination at the pressure port), the STALL WARN FAIL alert will be annunciated and the aural stall warning is muted until the fault clears.

The system operates on 28 VDC supplied though the 2-amp STALL WARNING circuit breaker on ESS BUS 2.

Pitot-Static System

The Pitot-Static system consists of a single heated Pitot tube mounted on the left wing and dual static ports mounted in the fuselage. The Pitot heat is pilot controlled through a panel-mounted switch. An internally mounted alternate static pressure source provides backup static pressure should that the primary static source becomes blocked. Water traps with drains, under the floor in the cabin, are installed at each Pitot and static line low point to collect any moisture that enters the system. The traps should be drained at the annual inspection and when water in the system is known or suspected.

Pitot Heat Switch

The heated Pitot system consists of a heating element in the Pitot tube, a rocker switch labeled PITOT HEAT, and associated wiring. The switch and circuit breaker are located on the left side of the switch and control panel. When the Pitot heat switch is turned on, the element in the Pitot tube is heated electrically to maintain proper operation in possible icing conditions. The Pitot heat system operates on 28 VDC supplied through the 7.5-amp PITOT HEAT circuit breaker on NON-ESSENTIAL BUS.

Pitot Heat Annunciation

Illumination of the PITOT HEAT FAIL Caution indicates that the Pitot Heat switch is ON and the Pitot heater is not receiving electrical current. Illumination of PITOT HEAT REQD Caution indicates the system detects OAT is less than 41 °F (5 °C) and Pitot Heat Switch is OFF. A current sensor on the Pitot heater power supply wire provides current sensing.

Alternate Static Source

An alternate static pressure source valve is installed on the switch and control panel to the right of the pilot's leg. This valve supplies static pressure from inside the cabin instead of the external static port. If erroneous instrument readings are suspected due to water or ice in the pressure line going to the standard external static pressure source, the alternate static source valve should be turned on. Pressures within the cabin will vary with open heater/vents. Whenever the alternate static pressure source is selected, refer to [Section 5: Performance Data](#) for airspeed calibration and altitude corrections to be applied.

Figure 7-16: Pitot-Static System - Serials w/o MD302 (1 of 2)

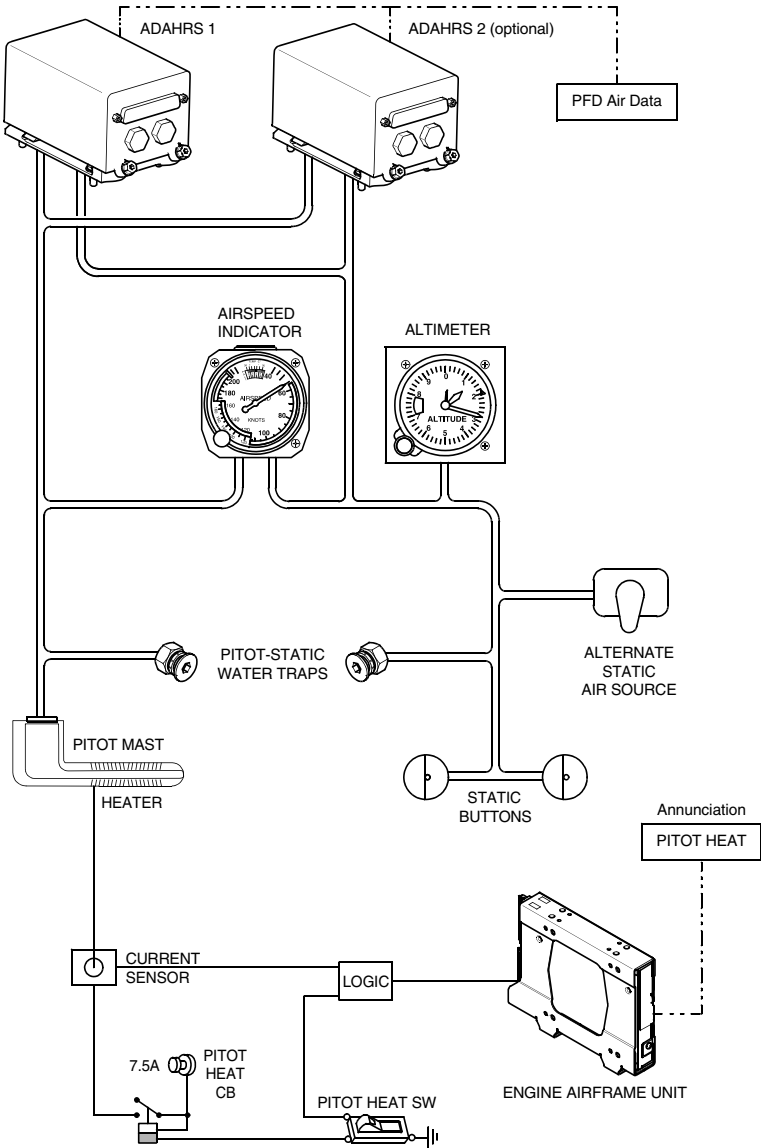

SR20_FM07_5383

Figure 7-16: Pitot-Static System - Serials w/ MD302 (2 of 2)

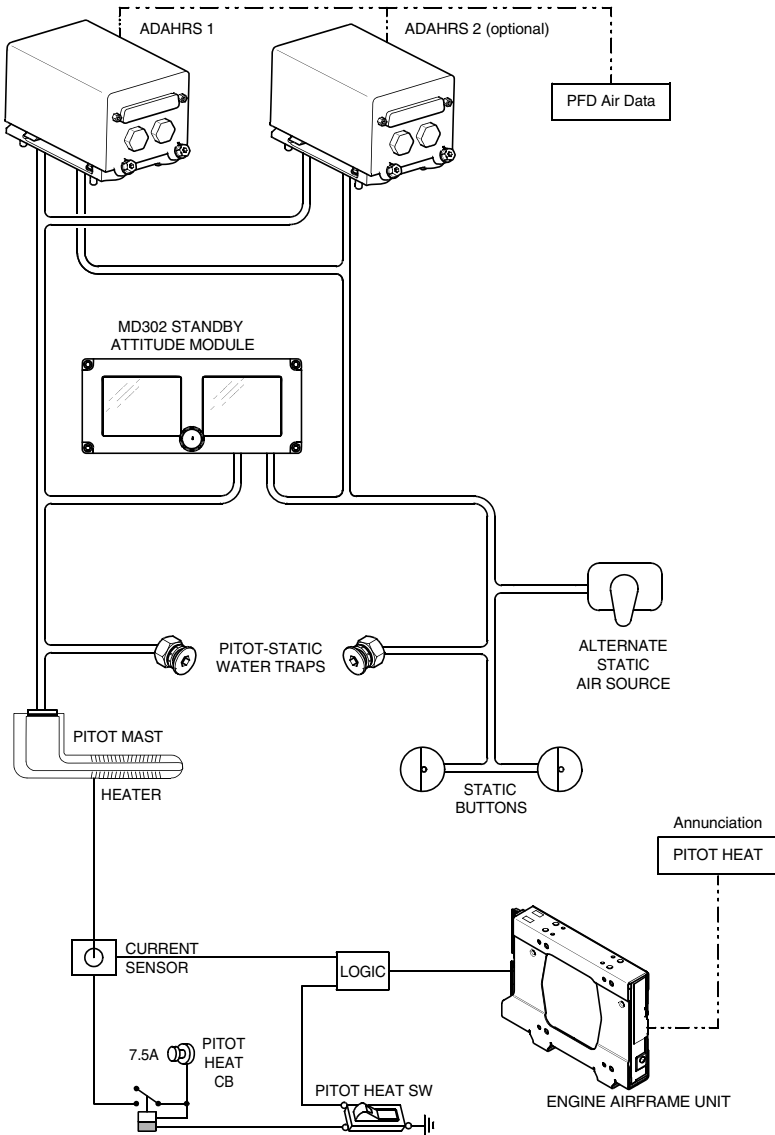

SR20_FM07_5384

Avionics

Perspective+ Integrated Avionics System

The Perspective+ Integrated Avionics System provides advanced cockpit functionality and improved situational awareness through the use of fully integrated flight, engine, communication, navigation and monitoring equipment, and consists of the following components:

- GDU 1050A Primary Flight Display (PFD), 10-inch, or GDU 1250A, 12-inch (optional)
- GDU 1050A Multifunction Display (MFD), 10-inch, or GDU 1250A, 12-inch (optional)
- GCU 479 Flight Management System Keyboard
- GSU 75 Air Data, Attitude and Heading Reference System
- GIA 63W/64W Integrated Avionics Units
- GEA 71/71B Engine Airframe Unit
- GTX 335 Mode S or GTX 345 Mode S UAT in (optional) Transponder
- GMA 350 or 350c (optional) Audio Panel w/ Marker Beacon Receiver
- GFC 700 Autopilot and GMC 707 Mode Controller
- GSR 56 Iridium Global Satellite Datalink (optional)
- GDL 69A XM Satellite Weather/Radio Receiver (optional)
- Flight Stream 510 Wireless Avionics Interface (optional)
- GTS 800 Traffic Advisory System (optional)
- Stormscope WX-500 Weather Mapping Sensor (optional)
- Bendix/King KN 63 Distance Measuring Equipment (optional)
- Synthetic Vision System (optional)
- SurfaceWatch (optional)
- Max Viz Enhanced Vision System (optional)
- MD302 Standby Attitude Module (optional)
- Gateway Module (optional)

Refer to the Perspective+ Integrated Avionics System Pilot's Guide (p/n 190-02183-XX, where X can be any digit from 0 to 9) for a detailed description of the system and its operating modes.

Figure 7-17: Perspective+ Integrated Avionics System Schematic

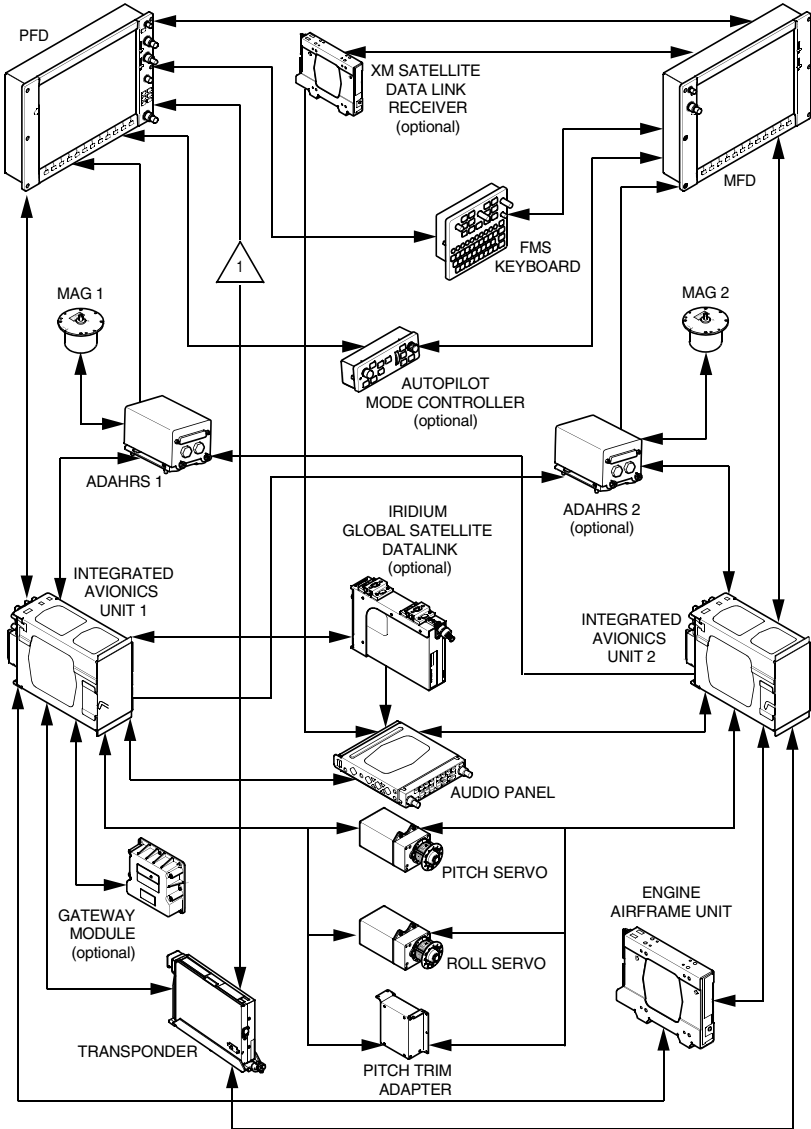

NOTE

1 Serials w/ GTX 345.

SR20_FM07_5362A

GDU 1050A Primary Flight Display (PFD), 10-inch, or GDU 1250A, 12-inch (Optional)

The Primary Flight Display, located directly in front of the pilot, is intended to be the primary display of flight parameter information (attitude, airspeed, heading, and altitude) during normal operations. The PFD accepts data from a variety of sources, including the MFD and the Integrated Avionics Units through a high-speed data bus connection. In conjunction with Flight Management System Keyboard, the PFD also controls and displays all communication and navigation frequencies as well as displaying warning/status annunciations on airplane systems. During engine start, reversionary operation (MFD failure), or when the DISPLAY BACKUP switch is selected, engine system information is displayed on the PFD.

Redundant power sources provide 28 VDC for PFD operation. Power is supplied through the 5-amp PFD A circuit breaker on ESS BUS 1 and the 5-amp PFD B circuit breaker on MAIN BUS 2. Either circuit is capable of powering the PFD. System start-up is automatic once power is applied. Power-on default brightness is determined by ambient lighting and is user adjustable. Typical alignment time is 60 seconds from battery turn on.

Display Backup Mode

In the event of a detected display failure, the Integrated Avionics System automatically switches to Display Backup Mode. In Display Backup Mode, all essential flight information from the PFD is presented on the remaining display in the same format as in normal operating mode with the addition of the Engine Indicating System. The change to backup is completely automated and no pilot action is required. However, if the system fails to detect a display problem, Display Backup Mode may be manually activated by pressing the red DISPLAY BACKUP Button. Pressing this button again deactivates Display Backup Mode.

GDU 1050A Multifunction Display (MFD), 10-inch, or GDU 1250A, 12-inch (Optional)

The Multifunction Display, located above the center console, depicts navigation, terrain, lightning, traffic data, NAV/COM frequencies, and annunciation information. All engine data is displayed on a dedicated ENGINE page. When the ENGINE page is not shown, all essential engine information is shown on an Engine Strip at the edge of the display.

Redundant power sources provide 28 VDC for MFD operation. Power is supplied through the 5-amp MFD A circuit breaker on MAIN BUS 3 and the 5-amp MFD B circuit breaker on MAIN BUS 1. Either circuit is capable of powering the MFD. System start-up is automatic once power is applied. Power-on default brightness is determined by ambient lighting and is user adjustable.

GCU 479 Flight Management System Keyboard

The Flight Management System Keyboard is found on the upper section of the center console and is the primary interface for avionics system data entry, PFD/MFD operation, NAV/COM tuning, and course selection.

28 VDC for Flight Management System Keyboard operation is supplied through the 5-amp KEYPADS / AP CTRL circuit breaker on MAIN BUS 1.

GSU 75 Air Data, Attitude and Heading Reference System (ADAHRS)

The Air Data, Attitude Heading and Reference System (ADAHRS) unit(s), mounted behind the PFD, includes the Attitude and Heading Reference System (AHRS) and the Air Data Computer (ADC).

The AHRS provides airplane attitude and heading information to both the PFD and the primary ADC. The AHRS contains advanced sensors (including accelerometers and rate sensors), and interfaces with the primary Magnetometer to obtain magnetic field information, the ADC to obtain air data, and both Integrated Avionics Units to obtain GPS information.

The ADC processes data from the Pitot/Static system and outside air temperature (OAT) sensor(s). The ADC provides pressure altitude, airspeed, vertical speed and OAT information to the Integrated Avionics System, and communicates with the PFD, Integrated Avionics Unit, and AHRS. The ADC is also connected directly to the Outside Air Temperature probe(s) and Pitot-Static System.

28 VDC for ADAHRS 1 operation is supplied through the 5-amp ADAHRS 1 circuit breaker on ESS BUS 1. If installed, 28 VDC for ADAHRS 2 operation is supplied through the 5-amp ADAHRS 2 circuit breaker on MAIN BUS 2.

Figure 7-18: Perspective+ Integrated Avionics System (1 of 2)

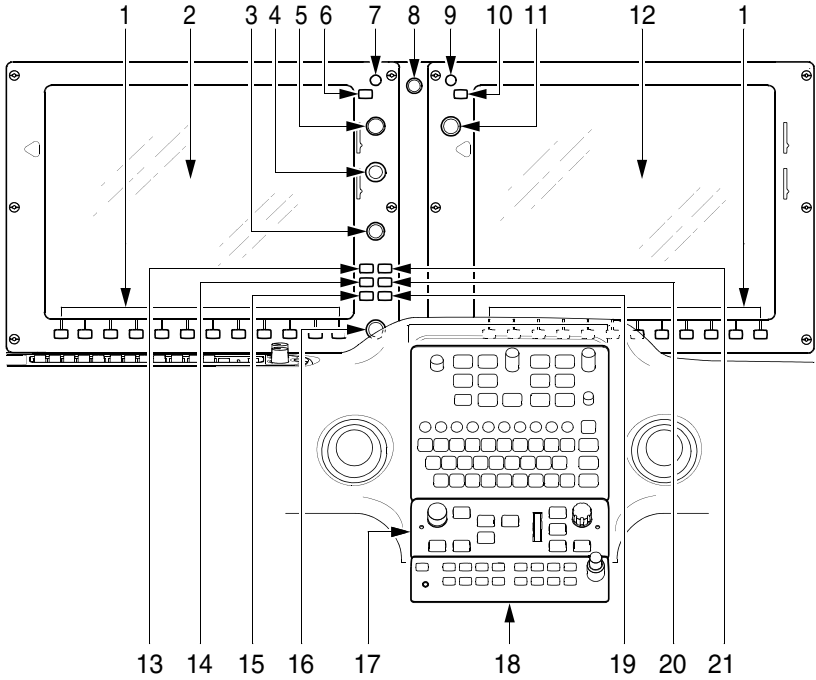

Legend

- | | |
|---|----------------------------------|
| 1. Soft Keys | 12. MFD |
| 2. PFD | 13. PFD Direct-to-Course |
| 3. PFD Range/Pan Joystick | 14. PFD Flight Plan Page |
| 4. Barometric Pressure | 15. PFD Clear/Cancel Information |
| 5. COM Transceiver Selection & Tune | 16. PFD Flight Management System |
| 6. COM Frequency Transfer | 17. GMC 707 Mode Controller |
| 7. COM Volume and Squelch
(& 121.5 Emer Tune) | 18. Audio Panel |
| 8. Display Backup Selection | 19. PFD Enter Key |
| 9. NAV and ID Audio Volume | 20. PFD Procedures |
| 10. NAV Frequency Transfer | 21. PFD Menu Key |
| 11. NAV Transceiver Selection & Tune | |

SR20_FM07_5388

Figure 7-18: Perspective+ Integrated Avionics System (2 of 2)

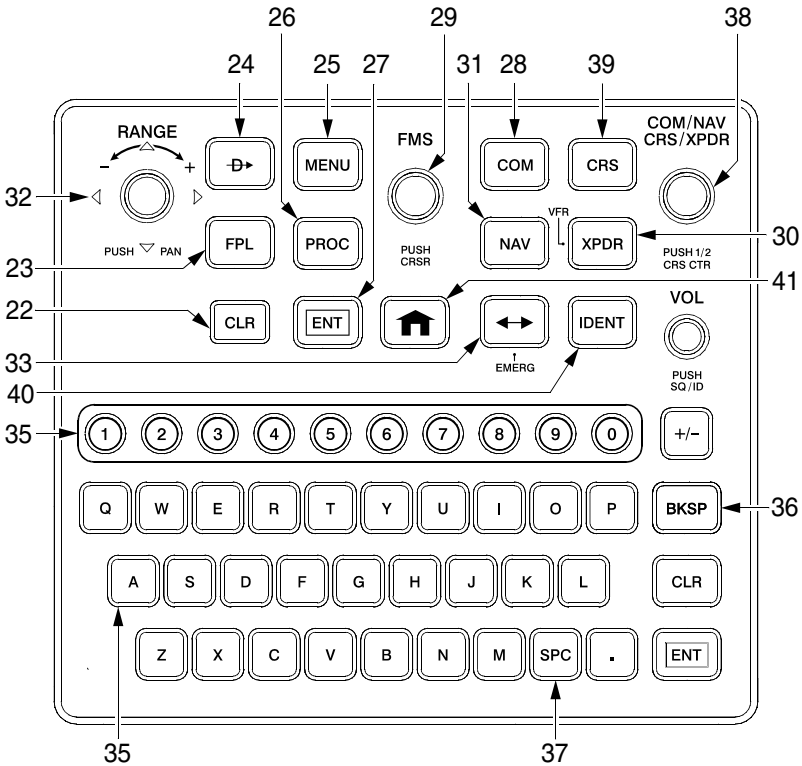

Flight Management System Keyboard

LEGEND

- | | |
|----------------------------------|-------------------------------------|
| 22. MFD Clear/Cancel Information | 32. MFD Range/Pan Joystick |
| 23. MFD Flight Plan Page | 33. Frequency Transfer (121.5 Tune) |
| 24. MFD Direct-to-Course | 34. MFD CRS/XPDR/NAV/COM Control |
| 25. MFD Menu | 35. Alphanumeric Keys |
| 26. MFD Procedures | 36. Backspace Key |
| 27. MFD Enter Key | 37. Space Key |
| 28. COM Tuning Mode | 38. Multi-function knob |
| 29. FMS Mode | 39. Course Selection (HSI) |
| 30. Transponder Mode (Ident) | 40. Ident |
| 31. NAV Tuning Mode | 41. Home Key |

SR20_FM07_5389

GIA 63W/64W Integrated Avionics Units

The Integrated Avionics Units, located behind the MFD and instrument panel, function as the main communication hub, linking all Integrated Avionics System components with the PFD. Each Integrated Avionics Unit contains a GPS WAAS receiver, VHF COM/NAV/GS receivers, system integration microprocessors, and flight director if the optional AFCS is installed.

28 VDC for Integrated Avionics Unit 1 operation is supplied through the 7.5-amp COM 1 and 5-amp GPS NAV GIA 1 circuit breakers on the ESS BUS 1. 28 VDC for Integrated Avionics Unit 2 operation is supplied through the 7.5-amp COM 2 and 5-amp GPS NAV GIA 2 circuit breakers on the MAIN BUS 2.

GEA 71/71B Engine Airframe Unit

The Engine Airframe Unit, mounted behind the MFD, receives and processes analog signals from the fuel gaging system, CHT, EGT, MAP, RPM and other sensors and transmits this data to the Integrated Avionics Unit.

28 VDC for Engine Airframe Unit operation is supplied through the 3-amp ENGINE INSTR circuit breaker on ESS BUS 2.

GTX 335 Mode S Transponder

The GTX 335 solid-state transponder communicates with the primary Integrated Avionics Unit and provides Modes A and C interrogation/reply capabilities. The transponder is controlled via the PFD or Flight Management System Keyboard and is located in the empennage avionics compartment.

28 VDC for Transponder operation is supplied through the 2-amp XPONDER circuit breaker on AVIONICS. Refer to the Perspective+ Integrated Avionics System Pilot's Guide for a complete description of the system, its operating modes, and additional detailed operating procedures.

GMA 350 or 350c Audio Panel with Marker Beacon Receiver

The 350 or 350c Audio Panel, installed on the center console below the Flight Management System Keyboard, integrates NAV/COM digital audio, intercom and marker beacon controls. The VHF communications portion of the unit interfaces with both Integrated Avionics Units to provide external radio communication, receive and demodulate VOR, Localizer, and Glide Slope signals.

28 VDC for Audio Panel operation is supplied through the 5-amp AUDIO PANEL circuit breaker on AVIONICS.

For a detailed operating instructions, refer to the GMA 350 or 350c Audio Panel Pilot's Guide.

Annunciation and Alert System

Aircraft annunciations and alerts are displayed in the Crew Alerting System (CAS) window located to the right of the altimeter and VSI. Aircraft annunciations are grouped by criticality and sorted by order of appearance with the most recent message on top. The color of the message text is based on its urgency and required action:

- Warning (red) – Immediate crew awareness and action required.
- Caution (yellow) – Immediate crew awareness and future corrective action required.
- Advisory (white) – Crew awareness required and subsequent action may be required.

In combination with the CAS Window, the system issues an audio alert when specific system conditions are met and an expanded description of the condition is displayed in the Alerts Window located in the lower RH corner of the PFD.

• NOTE •

For specific pilot actions in response to System Annunciations, refer to [Section 3: Emergency Procedures](#), and [Section 3A: Abnormal Procedures](#).

For additional information on Engine Instrument Markings and Annunciations, refer to [Section 2: Limitations](#).

GFC 700 3-Axis Autopilot and GMC 707 Autopilot Controller

Refer to latest revision of AFM Supplement 11934-S57, GFC 700 Automatic Flight Control System, for operating information.

Approach Baro-VNAV

While executing an LNAV/VNAV approach with SBAS unavailable, Baro-VNAV is used for vertical approach guidance. This occurs due to any of the following conditions:

- SBAS fails or becomes unavailable prior to final approach fix (FAF)
- the aircraft is outside SBAS coverage
- SBAS is manually disabled on the GPS Status page (To simulate a Baro-VNAV approach, SBAS must be manually disabled prior to activation of the approach procedure.)

Baro-VNAV is also the source of vertical approach guidance if the LNAV/VNAV procedure does not support SBAS vertical guidance.

While Baro-VNAV is being utilized, the Glidepath Indicator appears as a magenta pentagon. If the approach type downgrades past the FAF, “NO GP” is displayed in place of the pentagon.

While executing an LNAV/VNAV approach, between FAF and missed approach point (MAP), excessive deviation indicators appear as vertical yellow lines to indicate an area where the vertical deviation exceeds ± 75 feet.

Autopilot Interface

The GFC 700 Automatic Flight Control System uses the GP mode via the APR button to follow Approach Baro-VNAV guidance, as opposed to the VNAV mode via the VNV button. When coupled in GP mode, the GFC 700 will not capture a preselected altitude while tracking a Baro-VNAV glidepath.

Approach Downgrades

For approaches with minimums that support both SBAS and baro altitude vertical guidance, downgrading or reverting to barometric altitude guidance is allowed prior to 60 seconds before the FAF. If SBAS becomes unavailable after the approach is active but prior to 60 seconds before the FAF, an approach downgrade may be performed (e.g. LPV to LNAV/VNAV) or a vertical source reversion to baro altitude may be performed (e.g. SBAS LNAV/VNAV to baro LNAV/VNAV).

If a loss of SBAS occurs prior to 60 seconds before the FAF, the system will determine whether or not the approach mode can be supported using Baro-VNAV. If Baro-VNAV can be supported, the “APR ADVISORY - SBAS VNAV not available. Using Baro VNAV.” message will be displayed on the PFDs and the vertical deviation indicator (VDI) will be flagged. If SBAS is required for the approach, the approach mode (e.g. LPV) will be shown in amber but the GPS/SBAS VDI will be displayed until 60 seconds prior to the FAF. If the SBAS integrity has not been restored at 60 seconds prior to the FAF, the system will display the “APR DWNNGRADE - Apr downgraded. Baro VNAV.” message and flag the VDI.

Once the pilot acknowledges either message by viewing it on the PFD, the VDI will be restored using baro altitude vertical guidance instead of SBAS. There is no downgrade from SBAS to barometric altitude after the FAF or within 60 seconds of the FAF; “LNAV” is the only downgrade option in those cases. For approaches using barometric vertical guidance, downgrade is not allowed; if altitude or temperature data becomes invalid, the vertical deviation will be flagged.

Sensor Failures

Serials w/ single Air Data Computer (ADC) installations: The Outside Air Temperature (OAT) from the ADC will be used. If the OAT becomes invalid, the VDI will be flagged as invalid.

Serials w/ dual Air Data Computer (ADC) installations: The Outside Air Temperature (OAT) from the selected-side ADC will be used. If the OAT becomes invalid, the VDI on that side will be flagged as invalid. The pilot must select the off-side ADC sensor and VDI will return regardless of if prior to or after the FAF.

Sensor Comparison Annunciation

Serials w/ dual Air Data Computer (ADC) installations:

The temperature compensated altitudes from ADC1 and ADC2 are continuously compared. If a miscompare of greater than 50 feet is detected, the text “VDI MISCOMP” is displayed in the sensor comparison annunciation area on the PFD in black text with an amber background.

When a temperature-compensated altitude is not available for comparison, a “VDI NO COMP” annunciation is posted in comparison annunciation area on the PFD in black text with a white background.

Figure 7-19: Baro-VNAV Vertical Deviation Indicator

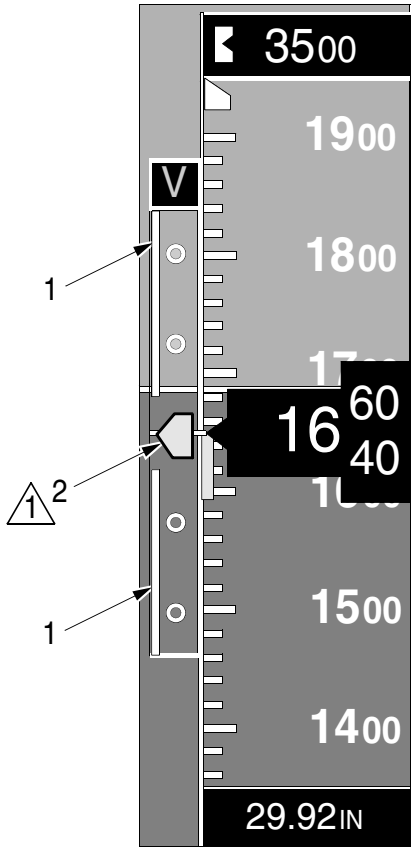

NOTE

 While Baro-VNAV is being utilized, the Glidepath Indicator appears as a magenta pentagon.

LEGEND

- 1. Excessive Deviation Indicator
- 2. Glidepath Indicator

SR20_FM07_5361

Optional Avionics

GTX 345 Mode S Transponder w/ UAT in

The GTX 345 solid state transponder communicates with the primary Integrated Avionics Unit, provides Modes A and C interrogation/reply capabilities, and performs the following functions:

- UAT Reception: The GTX 345 receives ADS-B, ADS-R, and TIS-B data transmitted on the 978 MHz frequency from other aircraft, vehicles, and ground stations for traffic awareness. In addition, the GTX 345 receives FIS-B data to provide graphical and textual weather products.
- Mode S Extended Squitter (ES) Reception: The GTX 345 receives ADS-B data transmitted by aircraft on the 1090 MHz frequency for traffic awareness.
- Output of graphical traffic and weather data to the MFD and PFD (ADS-B IN).

The transponder is controlled via the PFD or Flight Management System Keyboard and is located in the empennage avionics compartment.

28 VDC for Mode S Transponder operation is supplied through the 2-amp XPONDER circuit breaker on AVIONICS. Refer to the Perspective+ Integrated Avionics System Pilot's Guide for a complete description of the system, its operating modes, and additional detailed operating procedures.

GSR 56 Iridium Satellite Network Transceiver

The Iridium Satellite Network Transceiver, mounted in the empennage avionics compartment, communicates with the primary Integrated Avionics Unit and Audio Panel to provide near real-time weather, voice, and data services to the cabin audio system and integrated displays. The GSR 56 receives near real-time satellite weather information for display on the MFD and PFD and can also provide telephone/voice communications and text messaging (SMS) through the Iridium Satellite Network. The voice service is available through the audio panel via the TEL (telephone) input selection. SMS and weather products are displayed on the MFD.

28 VDC for Iridium Satellite Network Transceiver operation is supplied through the 5-amp DATA LINK/WEATHER circuit breaker on AVIONICS. Refer to the Perspective+ Integrated Avionics System Pilot's Guide for a complete description of the system, its operating modes, and additional detailed operating procedures.

GDL 69A XM Satellite Weather and Radio

The Data Link Satellite Receiver, mounted in the empennage avionics compartment, receives and transmits real-time weather information to the MFD and PFD. This unit also provides digital XM audio entertainment to the cabin audio system via the audio panel. It is controlled by MFD or the Flight Stream 510 Wireless Avionics Interface.

28 VDC for Satellite Datalink Receiver operation is supplied through the 5-amp WEATHER/DATA LINK circuit breaker on AVIONICS. Refer to the Perspective+ Integrated Avionics System Pilot's Guide for a complete description of the system, its operating modes, and additional detailed operating procedures.

GTS 800 Traffic Advisory System

The GTS 800 Traffic Advisory System (TAS) advises the pilot of transponder-equipped airplane that may pose a collision threat. TAS information is displayed on the MFD and indicates the relative range, bearing, and altitude of intruder airplane. The Traffic Advisory System consists of a Transmitter Receiver Computer under the LH cockpit seat, and two directional antennas installed on the airplane exterior. The system utilizes inputs from the secondary Integrated Avionics Units via the primary Air Data Computer and is controlled via the MFD or Flight Management System Keyboard.

28 VDC for Traffic Advisory System operation is supplied through the 5-amp TRAFFIC circuit breaker on AVIONICS. Refer to the Perspective+ Integrated Avionics System Pilot's Guide for a general description of the system and its operating modes.

Stormscope WX-500 Weather Mapping Sensor

The Stormscope WX-500 System detects electrical discharges associated with thunderstorms and displays the activity on the MFD. The system consists of an antenna located on top of the fuselage and a processor unit mounted under the aft baggage floor. The antenna detects the electrical and magnetic fields generated by intra-cloud, inter-cloud, or cloud to ground electrical discharges occurring within 200 nm of the airplane and sends the "discharge" data to the processor. The processor digitizes, analyzes, and converts the "discharge" signals into range and bearing data and communicates the data to the MFD every two seconds via the secondary Integrated Avionics Unit.

28 VDC for Weather System operation is supplied through the 5-amp DATA LINK/WEATHER circuit breaker on AVIONICS. Refer to the Perspective+ Integrated Avionics System Pilot's Guide for a general description of the system and its operating modes. If applicable, refer to the L-3 Stormscope WX-500 Weather Mapping Sensor Pilot's Guide for a detailed discussion of the system.

Bendix/King KN 63 Distance Measuring Equipment (DME)

The KN 63 DME determines airplane distance to a land-based transponder by sending and receiving pulse pairs - two pulses of fixed duration and separation. The ground stations are typically collocated with VORs. The system consists of an antenna installed on the airplane exterior and the KN 63 receiver which communicates with the Integrated Avionics System via the secondary Integrated Avionics Unit. 28 VDC for DME System operation is supplied through the 3-amp DME/ADF circuit breaker on AVIONICS. Refer to the Perspective+ Integrated Avionics System Pilot's Guide for a general description of the system and its operating modes. Refer to the Bendix/King DME System Pilot's Guide for a detailed discussion of the system.

Synthetic Vision System

The Synthetic Vision System (SVS) is intended to provide the pilot with enhanced situational awareness by placing a three dimensional depiction of terrain, obstacles, traffic and the desired flight path on the PFD so that proximity and location is more easily understood during instrument scanning. The SVS database is created from a digital elevation model with a 9 arc-sec (approx. 885 ft (270m)) horizontal resolution.

The synthetic vision system is not intended to be used independently of traditional attitude instrumentation. Consequently, SVS is disabled when traditional attitude instrumentation is not available. Otherwise, the traditional attitude instrumentation will always be visible in the foreground with SVS features in the background. The PFD with SVS installed includes:

- Perspective depiction of surrounding terrain,
- Zero pitch line,
- Perspective depiction of runways,
- Perspective depiction of large bodies of water,
- Perspective depiction of obstacles,
- Flight path marker,
- Terrain warning system, and
- Field of view depiction on the MFD Navigation Page.

Refer to the Perspective+ Integrated Avionics System Pilot's Guide for a complete description of the system, its operating modes, and additional detailed operating procedures.

Max Viz Enhanced Vision System

The Enhanced Vision System is an electro-optical system that uses a Long-Wave Infrared (IR) camera. Infrared is particularly effective at night, smoke, haze, and smog in addition to a broad spectrum of rain, snow, and radiation-type fog. However, penetration is limited during certain environmental conditions associated with heavy rain, heavy snow, coastal fog and most cloud formations. Therefore, the EVS is not intended for all atmospheric conditions and may only be used for acquisition of objects normally viewed through the cockpit windows. EVS is an aid to visual acquisitions of:

- Ground vehicles and other ground-based equipment/obstacles,
- Aircraft on taxi-ways and runways,
- Other traffic during takeoff, approach, and landing,
- Runway and taxi lights, and
- Runway and terrain features during climb, descent, and low altitude maneuvering.

The EVS sensor, located on the underside of the LH wing, contains a long-wave infrared camera that produces an infrared image and a lowlight CMOS camera that produces a visible image. The two images are then combined to produce a single fused image and transmitted directly to the MFD. Upon power-up, the sensor requires approximately 90 seconds to produce a usable image. The image generated is a monochrome image. The hotter an object is the whiter it appears on the display.

28 VDC Enhanced Vision System operation is supplied through the 5-amp EVS CAMERA circuit breaker on MAIN BUS 3. Refer to the Max Viz Enhanced Vision System Pilot's Guide for a detailed discussion of the system. For maintenance information and special precautions to be followed, refer to Section 8, [Enhanced Vision System Sensor Windows \(Optional\)](#).

SurfaceWatch

The SurfaceWatch feature displays visual annunciations and runway and taxiway information on the PFD to improve pilot situational awareness during ground operations and air operations in the airport environment.

Refer to the Cirrus Perspective+ Integrated Flight Deck Pilot's Guide for a detailed discussion of the SurfaceWatch feature.

Flight Stream 510 Wireless Avionics Interface

The Flight Stream 510 Wireless Avionics Interface allows the connection of a compatible mobile electronic device to the avionics. The Flight Stream 510 utilizes a Bluetooth™ connection for pairing up to 4 devices as well as a Wi-Fi connection for wireless database transfer. The Flight Stream 510 is installed in the bottom MFD card slot.

• CAUTION •

AHRS information transmitted by Flight Stream 510 is not to be used as a primary source of aircraft attitude information.

Data output from the Flight Stream 510 can be used to provide additional situational awareness for the pilot and passengers. Flight plans can be transferred between compatible mobile devices and the integrated avionics system using supported mobile applications. The Flight Stream 510 also serves as a wireless GDL 69 controller through which the aircraft crew or passengers can select Sirius/XM audio channels and control volume.

Power for Flight Stream 510 operation is supplied through the MFD which is powered by the 5-amp MFD A circuit breaker on Main Bus 3 and the 5-amp MFD B circuit breaker on Main Bus 1.

For a complete description of the Flight Stream 510 system, its operating modes, and additional detailed operating procedures, refer to the Perspective Integrated Avionics System Pilot's Guide.

Gateway Module

The Gateway Module collects aircraft data from the aircraft avionics and provides a cellular connection while on the ground for automatic transmission of aircraft data. This data can then be accessed by the pilot via a mobile application provided by Cirrus. The Gateway Module also provides access to the current status of aircraft consumables when the aircraft is unattended by remotely powering select systems on the aircraft when requested via the mobile application.

Figure 7-20: Equipment Locations

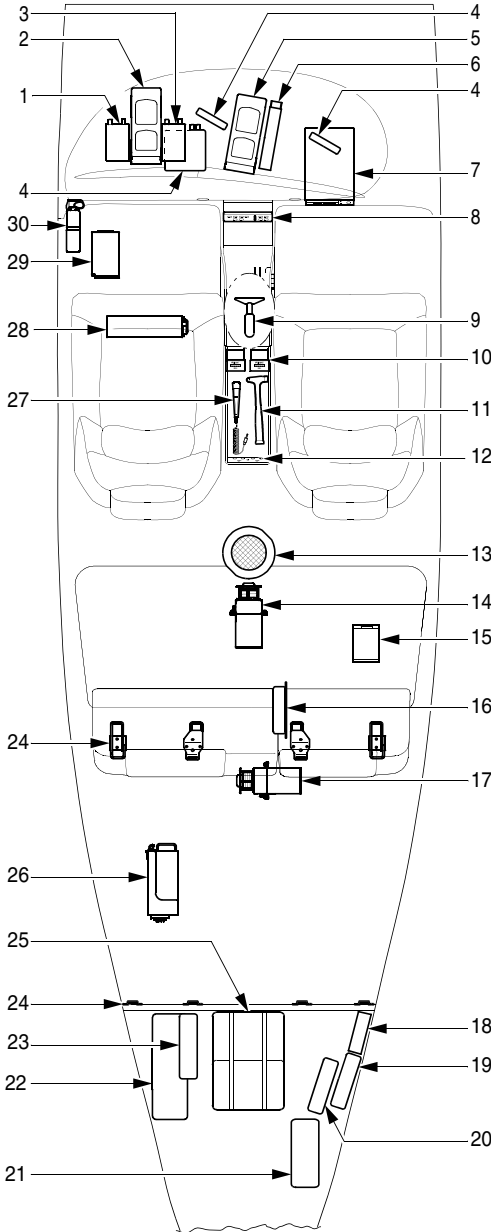

LEGEND

1. GSU 75 ADAHRS 1
2. Integrated Avionics Unit 1
3. GSU 75 ADAHRS 2 (opt)
4. Avionics Cooling Fan
5. Integrated Avionics Unit 2
6. Engine Airframe Unit
7. ADF (opt)
8. GMC 707 Mode Controller
9. CAPS Activation Handle (Cabin Ceiling)
10. Hour Meters
11. Egress Hammer
12. Passenger Audio & USB Jacks
13. Cabin Speaker
14. Roll Servo
15. Convenience System Controller
16. Pitch Trim Adapter (opt)
17. Pitch Servo
18. Gateway Module (opt)
19. Transponder
20. XM Satellite Data Link Receiver (opt)
21. ELT
22. Battery 2
23. Iridium Global Satellite Datalink (opt)
24. Tiedown Loops
25. CAPS Parachute
26. Stormscope WX-500 (opt)
27. Microphone (opt)
28. TAS Receiver (opt)
29. DME (opt)
30. Fire Extinguisher

SR20_FM07_5391B

Avionics Support Equipment

Antennas

Two rod-type COM antennas are mounted to the airplane's exterior; COM 1 is mounted directly above the passenger compartment, COM 2 is mounted directly below the baggage compartment. These antennas are connected to the two VHF communication transceivers contained in the Integrated Avionics Units.

The optional blade-type DME antenna is mounted on the airplane underside just aft, right of the firewall.

A sled-type marker beacon antenna is mounted below the baggage compartment floor and provides a signal to the marker beacon receiver located in the audio panel. If the optional air conditioning system is installed, this antenna is located below the baggage floor inside of the airplane.

The transponder antenna is located on the bottom side of the airplane, just aft of the baggage compartment bulkhead on the RH side of the airplane.

GPS 1 antenna is mounted directly above the passenger compartment. If the optional XM system is installed, a combination GPS 1/ XM antenna is installed in this location. A combination GPS 2 /Iridium antenna is mounted just forward of the baggage compartment window. These antennas are connected to the two GPS receivers contained in the Integrated Avionics Units.

The optional Traffic System antenna is mounted just above the pilot/copilot compartment.

If the GTS 800 Traffic Advisory System is installed, a second blade-type antenna is located on the bottom RH side of the airplane just forward of the baggage compartment.

The optional Lightning Detection antenna is mounted directly above the passenger compartment.

The Navigation antenna is mounted to the top of the vertical fin. This antenna provides VOR and glidescope signals to the VHF navigation receivers contained in the Integrated Avionics Units.

If the Gateway Module is installed, two internally mounted antennas are located on the RH side of airplane just aft of empennage access panel.

Headset and Microphone Installation

The airplane is equipped with provisions for five Active Noise Reduction (ANR) and three conventional (MIC/HEADPHONES) headsets. Headset jacks for the pilot, front, and rear seat passenger are located in the map case.

The forward headset mics use the remote Push-To-Talk (PTT) switches located on the top of the associated control yoke grip. The rear headsets do not have COM transmit capabilities and do not require PTT switches. Audio to headsets is controlled by the individual audio selector switches on the audio control panel.

Audio Input Jack

The aircraft contains an audio input jack which can be used to connect personal entertainment devices into the cabin sound system.

A single 3.5-mm audio input jack (AUDIO INPUT) is provided on the center console near the convenience outlet.

Distribution of a device connected to this jack is through the MUS 1 selection on the audio panel.

An additional 3.5-mm jack on the front of the audio panel will also accept a mobile device input. A device connected to this jack is distributed by selecting the Entertainment button (shown as a phone and music-note symbol) on the audio panel. Audio volume can be controlled by the device itself and can be further refined by the audio panel distribution volume control.

Avionics Cooling Fans

Three electric fans provide forced ambient-air cooling for the Integrated Avionics System. A fan located forward of the instrument panel provides ambient air cooling directly to the Integrated Avionics Units. Two additional fans blow air directly onto the heat sinks located on the forward sides of the PFD and MFD.

28 VDC for MFD Fan operation is supplied through the 5-amp AVIONICS FAN 1 circuit breaker on NON-ESSENTIAL BUS. 28 VDC for PFD and Integrated Avionics Unit Fan operation is supplied through the 5-amp AVIONICS FAN 2 circuit breaker on MAIN BUS 2.

Cabin Features

Emergency Locator Transmitter (ELT)

The airplane is equipped with a self-contained Artex ELT 1000 406 MHz emergency locator transmitter that generates a signal to assist in search and rescue for missing aircraft. The transmitter is automatically activated upon sensing a change of velocity along its longitudinal axis exceeding 4 to 5 feet per second, or upon sensing deployment of the Cirrus Airframe Parachute System (CAPS). Once activated, the ELT transmits VHF band audio sweeps at 121.5 MHz until battery power is gone.

In addition, for the first 24 hours of operation, a 406 MHz signal is transmitted at 50-second intervals. This transmission lasts 440 milliseconds and contains aircraft-specific information and GPS position data provided by the Garmin avionics. The transmitted data is referenced in a database maintained by the national authority responsible for ELT registration to identify the beacon and owner.

The ELT transmitter is installed immediately behind the aft cabin bulkhead, slightly to the right of the airplane centerline. The transmitter and antenna are accessible through the avionics bay access panel along the aft portion of the RH fuselage or the lower aft center access panel of baggage compartment.

The main transmitter control switch is labeled “ON” - “ARM/OFF” - “TEST”. The transmitter is in the armed position for normal operations. A red LED annunciator flashes when the ELT is transmitting.

A battery pack consisting of two “D” cell lithium batteries mounts to a cover assembly within the transmitter to provide power to the transmitter. The expiration date of the batteries is indicated on the outside of the ELT battery case and recorded in the aircraft logs.

A warning buzzer is mounted to the ELT shelf. When the ELT is activated, the buzzer “beeps” periodically. This buzzer operates in tandem with the ELT panel indicator and serves as a redundant annunciation. Power to the buzzer is supplied by the ELT batteries.

ELT Remote Switch and Indicator Panel

The Artex ELT 1000 Remote Switch and Control Panel Indicator (RCPI) is located below the Alternate Induction Air Control knob near the pilot’s right knee. The RCPI provides test and monitoring functions for the transmitter. The panel contains a two-wire switch labeled “ON” - “ARM/OFF” - “TEST”, and a red LED annunciator. The red LED annunciator flashes when the ELT is transmitting.

Figure 7-21: Artex ELT 1000 System

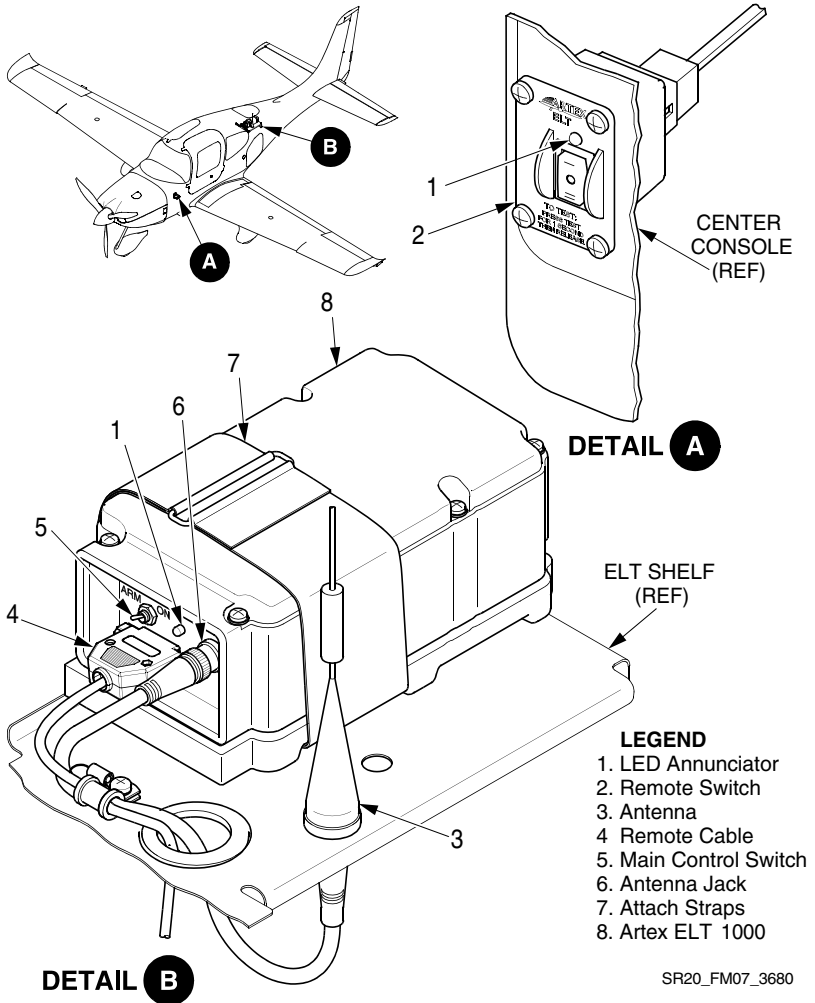

To Use ELT portably

The ELT transmitter can be removed from the airplane and used as a personal locating device if it is necessary to leave the airplane after an accident. Access the unit as described below and set the ELT transmitter control switch to the ON position.

1. Remove avionics bay access panel along aft portion of RH fuselage or lower aft center access panel of baggage compartment.
2. Disconnect fixed antenna lead from front of unit.
3. Disconnect lead from remote switch and indicator unit.
4. Disconnect antenna from mounting tray.
5. Loosen attach straps and remove transmitter unit.
6. Attach antenna to antenna jack on front of unit.
7. Set main control switch to ON position.
8. Hold antenna upright as much as possible.

Fire Extinguisher

A liquefied-gas-type fire extinguisher, containing Halon 1211, is mounted on the forward outboard side of the pilot-side footwell. The extinguisher is approved for use on class B (liquid, grease) and class C (electrical equipment) fires. A pin is installed through the discharge mechanism to prevent inadvertent discharge of extinguishing agent. The fire extinguisher must be recharged or replaced after each use.

To Operate Extinguisher

1. Loosen retaining clamp and remove the extinguisher from its mounting bracket.
2. Hold the extinguisher upright and pull the pin.
3. Get back from the fire and aim nozzle at base of fire at the nearest edge.
4. Press red lever and sweep side to side.

• WARNING •

Halon gas used in the fire extinguisher can be toxic, especially in a closed area. After discharging fire extinguisher, ventilate cabin by opening air vents and unlatching door. Close vents and door after fumes clear.

The extinguisher must be inspected before each flight to ensure that it is available, charged, and operable. The preflight inspection consists of ensuring that the nozzle is unobstructed, the pin has not been pulled, and the canister has not been damaged. The unit should weigh approximately 2.5 lb (1.1 kg). For preflight, charge can be determined by verifying the gauge pressure is in the operable (green) range, or by 'hefting' the unit.

Hour Meters

The airplane is equipped with two hour meters located inside the armrest storage compartment between the pilot and copilot seats. The #1 hour meter, labeled HOBBS begins recording when the BAT 1 switch is ON and either the ALT 1 or ALT 2 switch is ON. The #2 hour meter records flight time and is labeled FLIGHT. Recording begins when the airplane reaches a speed of approximately 35 KIAS and is controlled by the Integrated Avionics Unit.

28 VDC for hour meter operation is supplied through the 5-amp FUEL QTY circuit breaker on MAIN BUS 1.

Emergency Egress Hammer

An eight-ounce ball-peen type hammer is located in the center armrest accessible to either front seat occupant. In the event of a mishap where the cabin doors are jammed or inoperable, the hammer may be used to break through the acrylic windows to provide an escape path for the cabin occupants.

Convenience Outlet(s)

Serials 2220, 2339 thru 2900:

A 12-volt convenience outlet is installed in the center console. The receptacle accepts a standard cigarette-lighter plug. The outlet may be used to power portable entertainment equipment. Amperage draw through the outlet must not exceed 3.5 amps.

Power for the 12-volt convenience outlet and is supplied through the 5-amp 12V & USB POWER circuit breaker on MAIN BUS 3.

USB Ports

Four Universal Serial Bus (USB) dedicated charging ports are installed in the center console. Two ports are located in the center console for use by the pilot and forward passenger, and two ports are located on the aft portion of the center console for use by the rear passengers.

There is no data or audio access at the ports. Amperage and/or power draw through each USB charging port must not exceed the output value specified on the port label.

Serials 2220, 2339 thru 2900:

All ports are 15W and comply with USB Battery Charging 1.2, USB Power Delivery 2.0, and are intended for USB-compatible devices only. Power for the USB ports is supplied through the 5-amp 12V & USB POWER circuit breaker on MAIN BUS 3.

Serials 8500 and subs:

All ports comply with USB Battery Charging 1.2 and are intended for USB-compatible devices only. One forward facing port is 60W, and complies with USB Power Delivery 3.0. One forward facing and two aft ports are 15W and comply with USB Power Delivery 2.0. Power for the USB ports is supplied through the 7.5-amp 12V & USB POWER circuit breaker on MAIN BUS 3.

Cirrus Airframe Parachute System

The airplane is equipped with a Cirrus Airframe Parachute System (CAPS) designed to bring the airplane and its occupants to the ground in the event of a life-threatening emergency. The system is intended to save the lives of the occupants but will most likely destroy the airplane and may, in adverse circumstances, cause serious injury or death to the occupants. Because of this it is important to carefully read Section 3 - Emergency Procedures, [CAPS Deployment Checklist](#) and Section 10 - Safety Information, [Cirrus Airframe Parachute System \(CAPS\)](#) to consider when and how you would use the system.

• WARNING •

The parachute system can be activated at any time. The solid-propellant rocket flight path is upward from the parachute cover. Stay clear of parachute canister area when airplane is occupied. Do not allow children in the airplane unattended.

System Description

The CAPS consists of a parachute, a solid-propellant rocket to deploy the parachute, a rocket activation handle, and a harness imbedded within the fuselage structure.

A composite box containing the parachute and solid-propellant rocket is mounted to the airplane structure immediately aft of the baggage compartment bulkhead. The box is covered and protected from the elements by a thin composite cover.

The parachute is enclosed within a deployment bag that stages the deployment and inflation sequence. The deployment bag creates an orderly deployment process by allowing the canopy to inflate only after the rocket motor has pulled the parachute lines taut.

The parachute itself is a 2400-square-foot round canopy equipped with a slider, an annular-shaped fabric panel with a diameter significantly less than the open diameter of the canopy. The slider has grommets spaced around its perimeter. The canopy suspension lines are routed through these grommets so that the slider is free to move along the suspension lines. Since the slider is positioned at the top of the suspension lines near the canopy, at the beginning of the deployment sequence the slider limits the initial diameter of the parachute and the rate at which the parachute inflates. As the slider moves down the suspension lines the canopy inflates.

A three-point harness connects the airplane fuselage structure to the parachute. The aft harness strap is stowed in the parachute canister and attached to the structure at the aft baggage compartment bulkhead. The forward harness straps are routed from the canister to firewall attach points just under the surface of the fuselage skin. When the parachute deploys, the forward harness straps pull through the fuselage skin covering from the canister to the forward attach points.

Activation Handle

CAPS is initiated by pulling the CAPS Activation T-handle installed in the cabin ceiling on the airplane centerline just above the pilot's right shoulder. A placarded cover, held in place with hook and loop fasteners, covers the T-handle and prevents tampering with the control. The cover is removed by pulling the black tab at the forward edge of the cover.

Pulling the activation T-handle will activate the rocket and initiate the CAPS deployment sequence. To activate the rocket, two separate events must occur:

1. Pull the activation T-handle from its receptacle. Pulling the T-handle removes it from the o-ring seal that holds it in place and takes out the slack in the cable (approximately two inches (5 cm) of cable will be exposed). Once the slack is removed, the T-handle motion will stop and greater force will be required to activate the rocket.
2. Clasp both hands around activation T-handle and pull straight downward with a strong, steady, and continuous force until the rocket activates. A chin-up type pull works best. Up to 45.0 pounds (20.4 kg) force, or greater, may be required to activate the rocket. The greater force required occurs as the cable arms and then releases the igniter switch plunger activating the electronic igniter.

• NOTE •

Jerking or rapidly pulling on the activation T-handle greatly increases the pull forces required to activate the rocket.

Attempting to activate the rocket by pushing the activation T-handle forward and down limits the force that can be applied.

Pulling the activation T-handle straight down generates the greatest force.

A maintenance safety pin is provided to ensure that the activation handle is not pulled during maintenance. However, there may be some circumstances where an operator may wish to safety the CAPS system; for example, the presence of unattended children in the airplane, the presence of people who are not familiar with the CAPS activation system in the airplane, or during display of the airplane.

The pin is inserted through the handle retainer and barrel locking the handle in the “safe” position. A “Remove Before Flight” streamer is attached to the pin.

• **WARNING** •

After maintenance has been performed or any other time the system has been safetied, operators must verify that the pin has been removed before further flight.

Deployment Characteristics

When the rocket launches, the parachute assembly is extracted outward due to rocket thrust and rearward due to relative wind. In approximately two seconds, the parachute will begin to inflate.

When air begins to fill the canopy, forward motion of the airplane will dramatically be slowed. This deceleration increases with airspeed but in all cases within the parachute envelope should be less than 3 g's. During this deceleration a slight nose-up may be experienced, particularly at high speed; however, the rear riser is intentionally snubbed short to preclude excessive nose-up pitch. Following any nose-up pitching, the nose will gradually drop until the airplane is hanging nose-low beneath the canopy.

Eight seconds after deployment, the rear riser snub line will be cut and the airplane tail will drop down into its final approximately level attitude. Once stabilized in this attitude, the airplane may yaw slowly back and forth or oscillate slightly as it hangs from the parachute. Descent rate is expected to be less than 1700 feet per minute with a lateral speed equal to the velocity of the surface wind. In addition, surface winds may continue to drag the airplane after ground impact.

• **CAUTION** •

Ground impact is expected to be equivalent to touchdown from a height of approximately 10 feet. While the airframe, seats and landing gear are designed to accommodate this stress, occupants must prepare for it in accordance with Section 3 - [CAPS Deployment Checklist](#).

• **NOTE** •

The CAPS is designed to work in a variety of airplane attitudes, including spins. However, deployment in an attitude other than level flight may yield deployment characteristics other than those described above.

Intentionally Left Blank

Section 8: Handling and Servicing

Table of Contents

Introduction.....	3
Operator's Publications	3
Service Publications	3
Obtaining Publications.....	4
Airplane Records and Certificates.....	4
Airworthiness Directives	5
Airplane Inspection Periods.....	5
Annual Inspection.....	5
100-Hour Inspection	6
Cirrus Design Progressive Inspection Program	6
Pilot Performed Preventative Maintenance	7
Ground Handling	8
Application of External Power	8
Towing.....	9
Taxiing.....	10
Parking	11
Tie Down	12
Leveling	12
Jacking	12
Servicing.....	13
Landing Gear Servicing.....	13
Brake Servicing	13
Tire Inflation.....	13
Propeller Servicing	14
Engine Oil Servicing	14
Fuel System Servicing.....	15
Battery Service	18
Key Fob Battery Replacement	18
Artex ELT 1000 Servicing.....	19
Cleaning Exterior Surfaces.....	21
Painted Surfaces	21
Exterior Windshield and Windows.....	21
Enhanced Vision System Sensor Windows (Optional).....	22
Engine Compartment	22
Landing Gear.....	23
Recommended Exterior Cleaning Products	24

Care of Graphics	25
Cleaning Interior Surfaces	29
Interior Windshield and Windows	29
Instrument Panel and Electronic Display Screens.....	30
Headliner and Trim Panels	30
Leather Upholstery and Seats	31
Carpets	31

Introduction

This section provides general guidelines for handling, servicing, and maintaining your aircraft. In order to ensure continued safe and efficient operation of your airplane, keep in contact with your Authorized Cirrus Service Center to obtain the latest information pertaining to your aircraft.

Operator's Publications

The FAA Approved Airplane Flight Manual and Pilot's Operating Handbook (POH) is provided at delivery. Additional or replacement copies may be obtained from Cirrus.

Service Publications

The following service publications are available for purchase from Cirrus:

- Airplane Maintenance Manual (AMM) – Maintenance Manual divided into chapters as specified by GAMA and ATA covering inspection, servicing, maintenance, troubleshooting, and repair of the airplane structure, systems, and wiring. Revision Service for this manual is also available. A current copy of the AMM is provided at delivery.
- Wiring Manual – Manual covering maintenance, troubleshooting, testing, and repair of the airplane electrical wiring.
- Illustrated Parts Catalog (IPC) – Catalog prepared to aid operators and mechanics to identify and procure replacement airplane parts.
- CAPS Component Maintenance Manual (CMM) – Maintenance Manual with Illustrated Parts List prepared to enable an authorized Cirrus CAPS technician to restore the system to a functional condition.
- Engine Operators and Maintenance Manual – Cirrus provides a Lycoming Engines Operator's and Maintenance Manual at the time of delivery. Engine and engine accessory overhaul manuals can be obtained from the original equipment manufacturer.
- Avionics Component Operator and Maintenance Manuals – Cirrus provides all available operator's manuals at the time of delivery. Maintenance manuals, if available, may be obtained from the original equipment manufacturer.

Cirrus publishes Service Bulletins, Service Advisories, and Service Information Letters. Copies can be obtained from Cirrus at www.cirrusaircraft.com.

- Service Bulletins – are of special importance. When a Service Bulletin affecting your plane is published, comply with it promptly.
- Service Advisory Notices – are used to notify you of optional Service Bulletins, supplier Service Bulletins or Service Information Letters affecting your airplane, and maintenance data or corrections not

requiring a Service Bulletin. Pay careful attention to the Service Advisory information.

Obtaining Publications

Pilot’s Operating Handbooks and aircraft service publications can be obtained from Cirrus at www.cirrusaircraft.com, or the Cirrus Connection at www.cirrusconnection.com.

Airplane Records and Certificates

The Federal Aviation Administration (FAA) requires that certain data, certificates, and licenses be displayed or carried aboard the airplane at all times. Additionally, other documents must be made available upon request. The mnemonic acronym “ARROW” is often used to help remember the required documents.

RELATED TABLE/FIGURE:

Refer to “Table 1: Required Documents”.

• NOTE •

Owners of aircraft not registered in the United States should check with the registering authority for additional requirements.

Table 1: Required Documents

Required Documents		Note
A	Airworthiness Certificate FAA Form 8100-2	Must be displayed at all times.
R	Registration Certificate FAA Form 8050-3	Must be in the aircraft for all operations.
R	Radio Station License FCC Form 556	Required only for flight operations outside the United States.
O	Operating Instructions	FAA Approved Airplane Flight Manual and associated aircraft placards fulfill this requirement.
W	Weight & Balance Data	Included in FAA Approved Airplane Flight Manual and Pilot’s Operating Handbook. Data must include current empty weight, CG, and equipment list.

Other Documents	Note
Airplane Logbook	Must be made available upon request.
Engine Logbook	Must be made available upon request.
Pilot's Checklist	Available in cockpit at all times.

Airworthiness Directives

The Federal Aviation Administration (FAA) publishes Airworthiness Directives (ADs) that apply to specific aircraft and aircraft appliances or accessories. ADs are mandatory changes and must be complied with within a time limit set forth in the AD. Operators should periodically check with Cirrus Service Centers or A&P mechanic to verify receipt of the latest issued AD for their airplane.

Airplane Inspection Periods

• NOTE •

14 CFR 1.1 defines time in service, with respect to maintenance time records, as “the time from the moment an aircraft leaves the surface of the earth until it touches it at the next point of landing.”

The #2 Hour Meter, located in the center console and labeled FLIGHT, begins recording when the airplane reaches approximately 35 KIAS and should be used to track maintenance time intervals as it more accurately records time in service than the #1 Hour Meter.

The inspection items specified in the Annual/100 Inspection have been determined by the average aircraft use rate of the typical owner. Non-commercially operated aircraft that are flown significantly more than 100 hours per year should consider additional inspections commensurate with the hours flown. 100-Hour Inspection or enrollment in a Progressive Inspection Program should be considered in addition to the normally required Annual Inspection. The Annual Inspection interval may also be shortened to accommodate high utilization rate.

Annual Inspection

Unless enrolled in a Progressive Inspection Program, The U.S. Federal Aviation Regulations require all civil aircraft must undergo a thorough Annual Inspection every twelve calendar months. Annual Inspections are due on the last day of the twelfth month following the last Annual Inspection. For example: If an Annual Inspection was performed on 19 November

2015, the next Annual Inspection will be due 30 November 2016. Annual Inspections must be accomplished regardless of the number of hours flown the previous year and can only be performed by a licensed Airframe and Powerplant (A&P) mechanic holding an Inspection Authorization (IA). Annual inspections can only be performed by facilities approved by Cirrus. The inspection is listed, in detail, in Chapter 5 of the Airplane Maintenance Manual.

100-Hour Inspection

If the airplane is used to carry persons or provide flight instruction for hire, the Federal Aviation Regulations require that the airplane undergo a 100-Hour Inspection every 100 hours of flight operation in addition to the Annual Inspection requirement. The scope of the 100-Hour Inspection is identical to the Annual Inspection, except that it can be accomplished by a licensed A&P mechanic. The 100-hour interval may be exceeded by not more than 10 flight hours in order to reach a place where the inspection can be accomplished. Any flight hours used to reach an inspection station must be deducted from the next 100-Hour Inspection interval. The inspection is listed, in detail, in Chapter 5 of the Airplane Maintenance Manual.

Cirrus Design Progressive Inspection Program

In lieu of the above requirements, an airplane may be inspected using a Progressive Inspection Program in accordance with the Federal Aviation Regulation Part 91.409(d).

The Cirrus Design Progressive Inspection Program provides for the complete inspection of the airplane utilizing a five-phase cyclic inspection program.

400 flight hours: A total of eight inspections are accomplished over the course of 400 flight hours, with an inspection occurring every 50 flight hours.

800 flight hours: A total of sixteen inspections are accomplished over the course of 800 flight hours, with an inspection occurring every 50 flight hours.

The inspection items to be covered in the Progressive Inspection are very similar to the Annual Inspection items. The Progressive Inspection will accomplish a full Inspection of the airplane at 400 (or 800) flight hours or at 12 calendar months.

The inspections are listed, in detail, in Chapter 5 of the Airplane Maintenance Manual.

Pilot Performed Preventative Maintenance

The holder of a Pilot Certificate issued under CFR Part 61 may perform certain preventive maintenance described in CFR Part 43, Appendix A. This maintenance may be performed only on an aircraft that the pilot owns or operates and which is not used in air carrier service. The regulation also stipulates that the pilot must also complete the appropriate logbook entries. The following is a list of the maintenance that the pilot may perform:

• NOTE •

The pilot should have the ability and manual procedures for the work to be accomplished.

The pilot may not accomplish any work involving the removal or disassembly of primary structure or operating system, or interfere with an operating system, or affect the primary structure.

- Remove, install, and repair tires.
- Clean, grease, or replace wheel bearings.
- Replace defective safety wire or cotter pins.
- Lubrication not requiring disassembly other than removal of non-structural items such as access covers, cowlings, or fairings.

• CAUTION •

Do not use unapproved lubricants. Unapproved lubricants may damage control system components, including but not limited to engine and flight controls. Refer to the AMM for approved lubricants.

- Replenish hydraulic fluid in the hydraulic and brake reservoirs.
- Refinish the airplane interior or exterior (excluding balanced control surfaces) with protective coatings.
- Repair interior upholstery and furnishings.
- Replace side windows.
- Replace bulbs, reflectors and lenses of position and landing lights.
- Replace cowling not requiring removal of the propeller.
- Replace, clean or set spark plug gap clearance.
- Replace any hose connection, except hydraulic connections, with replacement hoses.
- Clean or replace fuel and oil strainers, as well as replace or clean filter elements.
- Replace prefabricated fuel lines.
- Replace the battery and check fluid level and specific gravity.

Logbook Entry

After any of the above work is accomplished, appropriate logbook entries must be made. Logbook entries should contain:

- The date the work was accomplished.
- Description of the work.
- Number of hours on the aircraft.
- The certificate number of pilot performing the work.
- Signature of the individual doing the work.

Logbooks should be complete and up to date. Good records reduce maintenance cost by giving the mechanic information about what has or has not been accomplished.

Ground Handling

Application of External Power

An external power receptacle, located just aft of the cowl on the left side of the airplane, permits the use of an external power unit for cold weather starting and maintenance procedures.

• WARNING •

If external power will be used to start engine, keep yourself, others, and power unit cables well clear of the propeller rotation plane.

To Apply External Power to Airplane

• CAUTION •

In accordance with the manufacturer's recommendation, external power should not be used to start the airplane with a dead battery or to charge a dead or weak battery in the airplane. The battery must be removed from the airplane and battery maintenance performed in accordance with the appropriate AMM procedures.

1. Ensure external power unit is regulated to 28 VDC.
2. Verify BAT and AVIONICS power switches are set to OFF.
3. Plug external power unit into the receptacle.
4. Set BAT 1 switch to ON. 28 VDC from the external power unit will energize the main distribution and essential distribution buses. The airplane may now be started or electrical equipment operated.
5. If avionics are required, set AVIONICS power switch ON.

• CAUTION •

If maintenance on avionics systems is to be performed, it is recommended that external power be used. Do not start or crank the engine with the AVIONICS power switch 'on.'

To Remove External Power from Airplane

1. If battery power is no longer required, set BAT 1 switch 'off.'
2. Pull external power unit plug.

Towing

The airplane may be moved on the ground by the use of the nose wheel steering bar that is stowed in the rear baggage compartment or by power equipment that will not damage or excessively strain the nose gear assembly. The steering bar is engaged by inserting it into lugs just forward of the nose wheel axle.

• CAUTION •

While pushing the aircraft backward, the tow bar must be installed to keep the nose wheel from turning abruptly.

Do not use the vertical or horizontal control surfaces or stabilizers to move the airplane. If a tow bar is not available, use the wing roots as push points.

Do not push or pull on control surfaces or propeller to maneuver the airplane.

Do not tow the airplane when the main gear is obstructed with mud or snow.

If the airplane is to be towed by vehicle, do not turn the nose wheel more than 90 degrees either side of center or structural damage to the nose gear could result.

To Tow Airplane

• CAUTION •

Be especially cognizant of hangar door clearances.

1. Refer to [Section 1: General, "Airplane Three View"](#) for turning radius clearances.
2. Insert tow bar into the lugs just forward of the nose wheel axle.
3. Release parking brake.
4. Remove chocks.
5. Move airplane to desired location.
6. Set parking brake in accordance with [Parking](#) procedure in this section.
7. Install chocks.
8. Remove tow bar.

To obtain a minimum radius turn during ground handling, the airplane may be rotated around either main landing gear by pressing down on the fuselage just forward of the horizontal stabilizer to raise the nose wheel off the ground.

Taxiing

Before attempting to taxi the airplane, ground personnel should be instructed and authorized by the owner to taxi the airplane. Instruction should include engine starting and shutdown procedures in addition to taxi and steering techniques.

• CAUTION •

Verify that taxi and propeller wash areas are clear before beginning taxi.

Do not operate the engine at high RPM when running up or taxiing over ground containing loose stones, gravel, or any loose material that may cause damage to the propeller blades.

Taxi with minimum power needed for forward movement. Excessive braking may result in overheated or damaged brakes.

Refer to [Section 10: Safety Information, "Taxiing, Steering, and Braking Practices"](#).

To Taxi Airplane

1. Remove chocks.
2. Start engine in accordance with [Engine Start](#) procedure.
3. Release parking brake.
4. Advance throttle to initiate taxi. Immediately after initiating taxi, apply the brakes to determine their effectiveness. To ascertain steering effectiveness during taxi, use differential braking to make slight turns.

• CAUTION •

Observe wing clearance when taxiing near buildings or other stationary objects. If possible, station an observer outside the airplane.

Avoid holes and ruts when taxiing over uneven ground.

5. Taxi airplane to desired location.
6. Shut down engine in accordance with [Shutdown](#) procedure.
7. Set parking brake in accordance with [Parking](#) procedure in this section.
8. Install chocks.
9. In gusty or stormy weather, moor airplane.

Parking

The airplane should be parked to protect the airplane from weather and to prevent it from becoming a hazard to other aircraft. The parking brake may release or exert excessive pressure because of heat buildup after heavy braking or during wide temperature swings. Therefore, if the airplane is to be left unattended or is to be left overnight, chock and tie down the airplane.

If the airplane will be parked for 30 days or more, pull the CONV LIGHTS circuit breaker to prevent excessive discharge from battery 1.

• NOTE •

Interior and exterior convenience lighting, electronic door locks, and Gateway Module will be disabled when CONV LIGHTS circuit breaker is pulled.

To Park Airplane

1. Position airplane on level surface and headed into the wind.
2. Retract flaps.

• CAUTION •

Use care if setting parking brake during cold weather when accumulated moisture may freeze brakes, or when brakes are overheated.

3. Set parking brake by first applying brake pressure using the toe brakes and then pulling the PARK BRAKE knob aft.
4. *If parking for more than 30 days:* Pull CONV LIGHTS circuit breaker.
5. Install chocks.
6. In gusty or stormy weather, tie down airplane in accordance with [Tie Down](#) procedure in this section.
7. Install a Pitot head cover.

• CAUTION •

Be sure to remove the Pitot head cover before flight.

8. Ensure cabin and baggage doors are locked when the airplane is left unattended.

Tie Down

The airplane should be moored for immovability, security, and protection. FAA Advisory Circular AC 20-35C, Tie-down Sense, contains additional information regarding preparation for severe weather, tie down, and related information.

To Tie Down (Moor) Airplane

1. Position airplane on level surface and headed into the wind.
2. Retract flaps.

• CAUTION •

Do not set parking brake during cold weather, when accumulated moisture may freeze brakes, or when brakes are overheated.

3. Set parking brake in accordance with [Parking](#) procedure in this section.
4. Install chocks.
5. Secure tie-down ropes to the wing tie-down rings and to the tail ring at approximately 45-degree angles to the ground. When using rope or non-synthetic material, leave sufficient slack to avoid damage to the airplane should the ropes contract.

• CAUTION •

Anchor points for wing tiedowns should not be more than 18 feet apart to prevent eyebolt damage in heavy winds.

Use bowline knots, square knots, or the midshipman's hitch (also known as a taut line hitch or half-hitch). Do not use plain slip-knots.

Regardless of which tie-down style is employed, ensure that the lines are taut and any slack is eliminated.

Leveling

Refer to AMM Chapter 8: Leveling & Weighing, Weighing the Airplane procedures for instructions and illustration.

Jacking

Refer to AMM Chapter 7: Lifting & Shoring, Jacking the Airplane procedures for list of required tools and for illustration.

Servicing

Landing Gear Servicing

The main landing gear wheel assemblies use 15 x 6.00 x 6 tubeless tires. The nose wheel assembly uses a 5.00 x 5 tubeless tire.

Always keep tires inflated to the rated pressure to obtain optimum performance and maximum service. The landing gear struts do not require servicing. With the exception of replenishing brake fluid, wheel and brake servicing must be accomplished in accordance with AMM procedures.

Brake Servicing

To Replenish Brake Fluid

The brake system is filled with MIL-PRF-87257 hydraulic brake fluid. The fluid level should be checked at every oil change and at the annual/100-hour inspection, replenishing the system when necessary. The brake reservoir is located on the right side of the battery support frame.

• **NOTE** •

If the entire system must be refilled, refer to AMM Chapter 12:
Servicing, Brake Fluid Replenishing.

1. Install chocks.
2. Release parking brake.
3. Remove top engine cowling to gain access to hydraulic fluid reservoir.
4. Clean reservoir cap and area around cap before opening reservoir cap.
5. Remove cap and add MIL-PRF-87257 hydraulic fluid as necessary to fill reservoir.
6. Install cap, inspect area for leaks, and then install and secure engine cowling.

Tire Inflation

For maximum service from the tires, keep them inflated to the proper pressure. When checking tire pressure, examine the tires for wear, cuts, nicks, bruises and excessive wear.

To Inflate Tires

1. Open access doors on wheel pants to gain access to valve stems. It may be necessary to move airplane to get valve stem aligned with the access hole.
2. Remove valve stem cap and verify tire pressure with a dial-type tire pressure gauge.

• CAUTION •

The LH and RH main wheel tire pressures must be within 20 psi of each other to ensure the load is evenly distributed between the main wheels.

3. Inflate nose tire to 30 - 35 psi (207 - 241 kPa) and main wheel tires to 60 - 65 psi (414 - 448 kPa).
4. Replace valve stem cap and close access doors.

Propeller Servicing

The spinner and backing plate should be cleaned and inspected for cracks frequently. Before each flight, the propeller should be inspected for nicks, scratches, and corrosion. If found, they should be repaired as soon as possible by a rated mechanic, since a nick or scratch causes an area of increased stress which can lead to serious cracks or the loss of a propeller tip. The back face of the blades should be painted when necessary with flat black paint to retard glare. To prevent corrosion, the surface should be cleaned and waxed periodically.

Refer to the shot peening requirement described in [Section 2: Limitations, "Propeller"](#).

Engine Oil Servicing

The total oil capacity of the Lycoming Engines IO-390-C3B6 engine is 8 quarts (7.6 liters). The engine oil sump has a capacity of 7 quarts, and the oil filter accounts for an additional 1 quart of the total capacity.

After the first 25 hours of operation, or four months, whichever occurs first, it is required that the oil be changed, the oil filter replaced, and the oil pressure screen be cleaned and inspected, in accordance with the manufacturer's instructions for continued airworthiness.

It is recommended that the oil be changed every 50 hours, or every four months, whichever occurs first, and sooner under unfavorable operating conditions.

Refer to Section 2, [Powerplant Limitations](#), for approved oil grades.

An oil filler cap and dipstick are located at the right rear of the engine and are accessible through an access door on the top right side of the engine cowling.

• CAUTION •

The engine must not be operated with less than six quarts of oil in the sump (dipstick indication). Seven quarts is recommended for extended flights.

To Check and Add Oil

1. Open access door on upper right-hand side of cowl. Pull dipstick and verify oil level.
2. If oil level is below 6 quarts (5.7 liters), remove filler cap and add oil through filler as required to reach 6 - 7 quarts (5.7 - 6.6 liters).
3. Verify oil level and install dipstick and filler cap.
4. Close and secure access panel.

Fuel System Servicing

Observe all safety precautions required when handling gasoline. Fuel fillers are located on the forward slope of the wing. Each wing holds a maximum of 29.3 U.S. gallons. When using less than the standard 58.5 gallon capacity, fuel should be distributed equally between each side.

• WARNING •

During fueling, have a fire extinguisher available.

Ground fuel nozzle and fuel truck to airplane exhaust pipe and ground fuel truck or cart to suitable earth ground.

Do not fill tank within 100 feet (30.5 meters) of any energized electrical equipment capable of producing a spark.

Smoking or open flames are prohibited within 100 ft (30.5 m) of airplane or refuel vehicle.

Do not operate radios or electrical equipment during refuel operations. Do not operate any electrical switches.

To Refuel Airplane

• CAUTION •

Aviation grade 100 LL (blue) or 100 (green) fuel is the minimum octane approved for use in this airplane.

1. Place fire extinguisher near fuel tank being filled.
2. Connect ground wire from refuel nozzle to airplane exhaust, from airplane exhaust to fuel truck or cart, and from fuel truck or cart to a suitable earth ground.
3. Place rubber protective cover over wing around fuel filler.

• NOTE •

Do not permit fuel nozzle to come in contact with bottom of fuel tanks. Keep fuel tanks at least half full at all times to minimize condensation and moisture accumulation in tanks. In extremely humid areas, the fuel supply should be checked frequently and drained of condensation to prevent possible distribution problems.

4. Remove fuel filler cap and fuel airplane to desired level.

• NOTE •

If fuel is going to be added to only one tank, the tank being serviced should be filled to the same level as the opposite tank. This will aid in keeping fuel loads balanced.

Refer to [Section 2: Limitations, "Fuel"](#) for maximum fuel imbalance information.

5. Remove nozzle, install filler cap, and remove protective cover.
6. Repeat refuel procedure for opposite wing.
7. Remove ground wires.
8. Remove fire extinguisher.

Fuel Filtration Screen/Element

After the first 25 hours of operation, then every 50-hours or as conditions dictate, the fuel filtration screen in the gascolator must be cleaned. After cleaning, a small amount of grease applied to the gascolator bowl gasket will facilitate reassembly.

Refer to AMM Chapter 28: Fuel, Fuel Screen/Element servicing procedures.

Fuel Contamination and Sampling

Typically, fuel contamination results from foreign material such as water, dirt, rust, and fungal or bacterial growth. Additionally, chemicals and additives that are incompatible with fuel or fuel system components are also a source of fuel contamination. To ensure that the proper grade of fuel is used and that contamination is not present, the fuel must be sampled prior to each flight.

Each fuel system drain must be sampled by draining a cupful of fuel into a clear sample cup. Fuel drains are provided for the fuel gascolator, wing tanks, and collector tank drains. The gascolator drain exits the lower engine cowl just forward of the firewall near the airplane centerline. Fuel tank and collector tank drains are located at the low spot in the respective tank.

If sampling reveals contamination, the gascolator and tank drains must be sampled again repeatedly until all contamination is removed. It is helpful to gently rock the wings and lower the tail slightly to move contaminants to the drain points for sampling. If after repeated samplings (three or more), evidence of significant contamination remains, do not fly the airplane until a mechanic is consulted, the fuel system is drained and purged, and the source of contamination is determined and corrected.

If sampling reveals the airplane has been serviced with an improper fuel grade, do not fly the airplane until the fuel system is drained and refueled with an approved fuel grade.

To help reduce the occurrence of contaminated fuel coming from the supplier or fixed based operator, pilots should ensure that the fuel supply has been checked for contamination and that the fuel is properly filtered. Also, between flights, the fuel tanks should be kept as full as operational conditions permit to reduce condensation on the inside of fuel tanks. In extremely humid areas, the fuel supply should be checked frequently and drained of condensation to prevent possible contamination.

De-Fueling

The bulk of the fuel may be drained from the wing fuel tanks by the use of a siphon hose placed in the cell or tank through the filler neck. The remainder of the fuel may be drained by opening the drain valves. Use the same precautions as when refueling airplane. Refer to the AMM for specific procedures.

• NOTE •

Refer to AMM Chapter 12: Servicing, Airplane De-Fueling procedures for more information.

Battery Service

The aircraft is delivered with a maintenance-free, rechargeable, sealed, lead acid primary battery. Battery #1 is mounted to the forward right side of the firewall and access is gained by removing the upper cowl. The battery vent is connected to an acid resistant plastic tube that vents gases and electrolyte overflow overboard.

A capacity check must be performed at initial 24 months or 1200 hours in service and then every 12 months or 200 hours thereafter. Refer to AMM Chapter 5: Time Limits And Maintenance Checks, Overhaul and Replacement Schedule.

Battery #2 is a maintenance-free, rechargeable, sealed, lead acid battery. Mounted in the empennage just aft of bulkhead 222, there is no need to check the specific gravity of the electrolyte or add water to these batteries during their service life. Refer to AMM Chapter 5: Time Limits And Maintenance Checks, Overhaul and Replacement Schedule.

The external power receptacle is located on the left side of the fuselage just aft of the firewall. Refer to AMM Chapter 24: Electrical Power, External Power for servicing procedures.

Key Fob Battery Replacement

Serials w/ Convenience Lighting:

If the key fob does not function properly at normal range, the battery should be replaced. To replace the key fob battery:

To Replace Key Fob Battery

1. Using a thin flat object, pry the top and bottom halves of the key fob apart.
2. Remove and replace the battery with a new CR2032, or equivalent, 3-volt battery. Install the new battery with the positive side (+) facing up, away from the circuit board.
3. Press the top and bottom halves of the key fob back together.

Artex ELT 1000 Servicing

The ELT batteries must be inspected in accordance with the Airplane Maintenance Manual, 5-20 - Scheduled Maintenance Checks.

The ELT batteries must be replaced upon reaching the date stamped on the batteries, after an inadvertent activation of unknown duration, or whenever the batteries have been in use for one cumulative hour.

Inspection / Test

After setting transmitter switch to TEST position, the ELT automatically enters a self-test mode. The self-test transmits a 406 MHz test coded pulse that monitors certain system functions before shutting off. The test pulse is ignored by any satellite that receives the signal, but the ELT uses this pulse to check output power and frequency. Other parameters of the ELT are checked and a set of error codes is generated if a problem is found. The error codes are indicated by a series of pulses on the transmitter LED, the Remote Switch and Control Panel Indicator (RCPI) LED, and alert buzzer.

• NOTE •

FAA regulations require that transmitter tests only be done during the first 5 minutes of each hour and must not last for more than 3 audio sweeps (1.5 seconds). If you are at a location where there is an FAA control tower or other monitoring facility, notify the facility before beginning the tests. Never activate the ELT while airborne for any reason.

Operators may wish to use a low quality AM broadcast receiver to determine if energy is being transmitted from the antenna. When the antenna of the radio (tuning dial on any setting) is held about 6 inches from the activated ELT antenna, the ELT aural tone will be heard on the AM broadcast receiver. This is not a measured check, but it does provide confidence that the antenna is radiating sufficient power to aid search and rescue. The aircraft's VHF receiver, tuned to 121.5 MHz, may also be used. This receiver, however, is more sensitive and could pick up a weak signal even if the radiating ELT's antenna is disconnected. Therefore, it does not check the integrity of the ELT system or provide the same level of confidence as does an AM radio.

To Service Artex ELT 1000

1. Tune aircraft receiver to 121.5 MHz.
2. Push switch lever to TEST position for approximately 1 second, and then release.
3. Results of the test are displayed by a series of indications (flash codes), where the local LED, remote switch LED and buzzer(s) activate for ½ second ON, followed by ½ second OFF. Error codes, indicated by

multiple flashes separated by 1-second periods, will begin to display after approximately 1 second.

4. Flash Codes displayed with the associated conditions are as follows:
 - a 1-Flash: Indicates that the system is operational and that no error conditions were found.
 - b 2-Flashes: Not used. If displayed, correct condition before further flight.
 - c 3-Flashes: Not used. If displayed, correct condition before further flight.
 - d 4-Flashes: Indicates low output power. If displayed, correct condition before further flight.
 - e 5-Flashes: Indicates no position data present. If displayed, correct condition before further flight.

• NOTE •

BAT1 must be powered on to provide position data to the ELT.

- f 6-Flashes: Indicates G-switch loop is not present. If displayed, correct condition before further flight.
- g 7-Flashes: Battery check. If displayed, correct condition before further flight.
- h 8-Flashes: Indicates programming data missing. If displayed, correct condition before further flight.

Cleaning Exterior Surfaces

• CAUTION •

Prior to cleaning, place the airplane in a shaded area to allow the surfaces to cool.

The airplane should be washed with a mild soap and water. Harsh abrasives or alkaline soaps or detergents could make scratches on painted or plastic surfaces or could cause corrosion of metal. Cover static ports and other areas where cleaning solution could cause damage. Be sure to remove the static port covers before flight.

Painted Surfaces

• NOTE •

Any good silicone-free automotive wax may be used to preserve painted surfaces. Soft cleaning cloths or a chamois should be used to prevent scratches when cleaning or polishing. A heavier coating of wax on the leading surfaces will reduce the abrasion problems in these areas.

To Clean Painted Surfaces

1. Flush away loose dirt with water.
2. Apply cleaning solution with a soft cloth, a sponge, or a soft bristle brush.
3. To remove exhaust stains, allow the solution to remain on the surface longer.
4. To remove stubborn oil and grease, use a cloth dampened with naphtha.
5. Rinse all surfaces thoroughly.

Exterior Windshield and Windows

Before cleaning an acrylic window, rinse away all dirt particles before applying cloth or chamois. Never rub dry acrylic. Dull or scratched window coverings may be polished using a special acrylic polishing paste.

• CAUTION •

Clean acrylic windows with a solvent-free, non-abrasive, antistatic acrylic cleaner. Do not use gasoline, alcohol, benzene, carbon tetrachloride, thinner, acetone, or glass window cleaning sprays.

Use only a non-abrasive cotton cloth or genuine chamois to clean acrylic windows. Paper towel or newspaper are highly abrasive and will cause hairline scratches.

To Clean Exterior Windshield and Windows

1. Remove grease or oil using a soft cloth saturated with kerosene then rinse with clean, fresh water.

• NOTE •

Wiping with a circular motion can cause glare rings. Use an up and down wiping motion on the windshield in the direction of the airflow to prevent this.

To prevent scratching from dirt that has accumulated on the cloth, fold cloth to expose a clean area after each pass.

2. Using a moist cloth or chamois, gently wipe the windows clean of all contaminants.
3. Apply acrylic cleaner to one area at a time, then wipe away with a soft, cotton cloth.
4. Dry the windows using a dry non-abrasive cotton cloth or chamois.

Enhanced Vision System Sensor Windows (Optional)

The Enhanced Vision System Sensor is located on the underside of the LH wing. The three sensor windows are made of Germanium. In contrast to visible light energy, infrared energy typically passes through dirt on the window. As such, the Sensor windows require only occasional cleaning.

• CAUTION •

If an EVS Sensor Window breaks, use gloves and masks when handling broken germanium window material.

Do not use abrasive cleansers or cleaning pads on the germanium window. Abrasive cleaning can damage the sensor window coating.

Do not use any cleansers containing ammonia. Ammonia will remove the sensor window coating.

To Clean EVS Sensor Windows

1. Apply mild liquid soap and water or isopropyl alcohol, then wipe away with a soft, cotton cloth.
2. Dry the sensor windows using a dry non-abrasive cotton cloth.

Engine Compartment

Before cleaning the engine compartment, place a strip of tape on the magneto vents to prevent any solvent from entering these units.

To Clean Engine Compartment

1. Place a large pan under the engine to catch waste.
2. Remove induction air filter and seal off induction system inlet.
3. With the engine cowling removed, spray or brush the engine with solvent or a mixture of solvent and degreaser. In order to remove especially heavy dirt and grease deposits, it may be necessary to brush areas that were sprayed.

• CAUTION •

Do not spray solvent into the alternator, vacuum pump, starter, or induction air intakes.

4. Allow the solvent to remain on the engine from 5 to 10 minutes. Then rinse engine clean with additional solvent and allow it to dry.

• CAUTION •

Do not operate the engine until excess solvent has evaporated or otherwise been removed.

5. Remove the protective tape from the magnetos.
6. Open induction system air inlet and install filter.
7. Lubricate in accordance with AMM Chapter 12: Servicing.

Landing Gear

Before cleaning the landing gear, place a plastic cover or similar material over the wheel and brake assembly.

To Clean Landing Gear

1. Place a pan under the gear to catch waste.
2. Spray or brush the gear area with solvent or a mixture of solvent and degreaser, as desired. Where heavy grease and dirt deposits have collected, it may be necessary to brush areas that were sprayed, in order to clean them.
3. Allow the solvent to remain on the gear from five to ten minutes. Then rinse the gear with additional solvent and allow to dry.
4. Remove the cover from the wheel and remove the catch pan.
5. Lubricate the gear in accordance with AMM Chapter 12: Servicing.

Recommended Exterior Cleaning Products

Cleaning Application	Cleaning Product	Supplier
Painted Exterior	Pure Carnauba Wax	Any Source
	Mothers California Gold Pure Carnauba Wax	Mothers Polish
	RejeX High Gloss Protective Finish	Corrosion Technologies
	WX/Block System	Wings and Wheels
	AeroShell Flight Jacket Plexicoat	Aeroshell
Painted Exterior and Landing Gear	XL-100 Heavy-Duty Cleaner/Degreaser	Buckeye International
Engine Compartment	Stoddard Solvent PD-680 Type II	Any Source
Exterior Windshield and Windows	Kerosene	Any Source
	Klear-To-Land	D.W. Davies & Co
	Plastic and Glass Cleaner	Prist Aerospace
	Acrylic Polish & Sealant	LP Aero Plastics

Care of Graphics

Graphics require care similar to any fine paint finish. Use high quality products designed specifically for use on automobile finishes. Use products in accordance with the manufacturer's instructions.

Graphics, like paint, are degraded by prolonged exposure to sun and atmospheric pollutants. Store aircraft in a hangar, under a cloth cover, or shaded area whenever possible. Protect aircraft from dew and rain which may contain acidic pollutants (commonly found in large metropolitan areas).

• CAUTION •

If graphics start to discolor or turn brown as a result of exposure to acidic pollution, immediately have a professional remove the graphic from the aircraft to avoid staining the underlying paint.

To Wash and Clean Graphics

Wash graphics whenever the aircraft appears dirty. Contaminants allowed to remain on the exterior may be more difficult to remove.

1. Rinse off as much dirt and grit as possible with a spray of water.
2. Clean graphic with a wet, non-abrasive detergent such as 3M™ Car Wash Soap 39000, Meguiar's NXT Generation® Car Wash, or Deep Crystal® Car Wash, and a soft, clean cloth or sponge.
3. Rinse thoroughly with clean water.
4. To reduce water spotting, immediately use a silicone squeegee to remove water.
5. Dry with a clean microfiber cloth.

To Pressure Wash Graphics

Although hand washing is preferred, pressure washing may be used when necessary to remove dirt and contaminants. Pressure washing must be performed in accordance with the following procedure:

1. Ensure water pressure is less than 2000 psi (14 MPa).
2. Ensure water temperature is less than 180 °F (82 °C).
3. Use a spray nozzle with a 40° wide angle spray pattern.

• CAUTION •

Holding the nozzle of a pressure washer at an angle less than 90° to the graphic may lift the edges of the graphic.

4. Keep the spray nozzle perpendicular to the graphic, and at a distance of at least 1 foot (30 cm).
5. To reduce water spotting, immediately use a silicone squeegee to remove water.
6. Dry with a clean microfiber cloth.

To Spot Clean Difficult Contaminants

Difficult contaminants such as bugs, bird droppings, or tree sap may require spot cleaning.

• CAUTION •

To prevent scratching the graphic, refrain from rough scrubbing and the use of abrasive tools.

1. Soften contaminants by soaking with hot, soapy water for several minutes.
2. Rinse thoroughly with clean water.
3. To reduce water spotting, immediately use a silicone squeegee to remove water.
4. Dry with a clean microfiber cloth.

• CAUTION •

Initially test cleaning products on an inconspicuous area of the graphic to verify they will not cause damage.

5. If further cleaning is needed, one of the following products may be used: Meguiar's Gold Class™ Bug and Tar Remover, 3M™ Citrus Base Cleaner, a mixture of two parts isopropyl alcohol to one part water (mix ratio 2:1), or denatured alcohol.
6. Immediately rinse off all residue with clean water.
7. To reduce water spotting, immediately use a silicone squeegee to remove water.
8. Dry with a clean microfiber cloth.

To Clean Fuel Spills

• CAUTION •

Immediately clean fuel spills to avoid degrading the vinyl and adhesive used in the graphic.

1. Wipe off spilled fuel.
2. Clean graphic with a wet, non-abrasive detergent such as 3M™ Car Wash Soap 39000, Meguiar's NXT Generation® Car Wash, or Deep Crystal® Car Wash, and a soft, clean cloth or sponge.
3. Rinse thoroughly with clean water.
4. To reduce water spotting, immediately use a silicone squeegee to remove water.
5. Dry with a clean microfiber cloth.

Graphic Restoration

If typical cleaning methods fail to produce satisfactory results, refer to the recommended restoration products and mixtures below to help preserve the condition of the graphics on your aircraft.

• CAUTION •

Do not use abrasive polishes or cutting compounds.

Do not use polish or wax on graphics with a matte or texture finish.

Initially test restoration products and mixtures on an inconspicuous area of the graphic to verify they will not cause damage.

• NOTE •

Use an all-purpose cleaner to remove wax or wax residue.

Recommended Graphic Restoration Products and Mixtures

Film or Finish Type	Cleaning Product or Mixture	Supplier
Smooth Gloss	3M™ Perfect-it™ Show Car Paste Wax 39526	3M Company
	Meguiar's Gold Class™ Carnuaba Plus Premium Liquid Wax	Meguiar's
Matte or Satin Texture	Mixture of two parts isopropyl alcohol to one part water (mix ratio 2:1)	Any Source
Matte White (1080-M10) Carbon Fiber White Texture (1080-CF10)	Depending on the type and degree of contamination to be removed, use one or more of the following solutions in the order shown: <ol style="list-style-type: none"> 1. Hot, soapy water solution 2. Mixture of two parts isopropyl alcohol to one part water (mix ratio 2:1) 3. Simple Green® All-Purpose Cleaner 4. Household chlorine bleach, followed by a mixture of two parts isopropyl alcohol to one part water (mix ratio 2:1) 5. Mineral spirits, followed by a mixture of two parts isopropyl alcohol to one part water (mix ratio 2:1) 	Any Source
Carbon Fiber or Brushed Metal Texture	3M™ Tire Restorer	3M Company
	Meguiar's Natural Shine Protectant	Meguiar's
Carbon Fiber Black Texture (1080-CF12)	Meguiar's Ultimate Black Plastic Restorer	Meguiar's

Cleaning Interior Surfaces

Seats, carpet, upholstery panels, and headliners should be vacuumed at regular intervals to remove surface dirt and dust. While vacuuming, use a fine bristle nylon brush to help loosen particles.

• **CAUTION** •

Remove any sharp objects from pockets or clothing to avoid damaging interior panels or upholstery.

Interior Windshield and Windows

Never rub dry acrylic. Dull or scratched window coverings may be polished using a special acrylic polishing paste.

• **CAUTION** •

Clean acrylic windows with a solvent-free, non-abrasive, antistatic acrylic cleaner. Do not use gasoline, alcohol, benzene, carbon tetrachloride, thinner, acetone, or glass window cleaning sprays.

Use only a non-abrasive cotton cloth or genuine chamois to clean acrylic windows. Paper towel or newspaper are highly abrasive and will cause hairline scratches.

• **NOTE** •

Wiping with a circular motion can cause glare rings. Use an up and down wiping motion on the windshield in the direction of the airflow to prevent this.

To prevent scratching from dirt that has accumulated on the cloth, fold cloth to expose a clean area after each pass.

To Clean Interior Windshield and Windows

1. Using a moist cloth or chamois, gently wipe the windows clean of all contaminants.
2. Apply acrylic cleaner to one area at a time, then wipe away with a soft, cotton cloth.
3. Dry the windows using a dry, non-abrasive cotton cloth or chamois.

Instrument Panel and Electronic Display Screens

The instrument panel, control knobs, and plastic trim need only to be wiped clean with a soft, damp cloth. The multifunction display, primary flight display, and other electronic display screens should be cleaned with Optimax - LCD Screen Cleaning Solution as follows:

• CAUTION •

To avoid solution dripping onto display and possibly migrating into component, apply the cleaning solution to cloth first, not directly to the display screen.

Use only a lens cloth or non-abrasive cotton cloth to clean display screens. Paper towels, tissue, or camera lens paper may scratch the display screen.

Clean display screen with power OFF.

To Clean Instrument Panel and Electronic Display Screens

1. Gently wipe the display with a dry, clean, cotton cloth.
2. Moisten clean cotton cloth with cleaning solution.
3. Wipe the soft cotton cloth across the display in one direction, moving from the top of the display to the bottom. Do not rub harshly.
4. Gently wipe the display with a dry, clean cotton cloth.

Headliner and Trim Panels

The airplane interior can be cleaned with a mild detergent or soap and water. Harsh abrasives or alkaline soaps or detergents should be avoided. Solvents and alcohols may damage or discolor vinyl or urethane parts. Cover areas where cleaning solution could cause damage.

• CAUTION •

Solvent cleaners and alcohol should not be used on interior parts. If cleaning solvents are used on cloth, cover areas where cleaning solvents could cause damage.

To Clean Headliner and Trim Panels

1. Clean headliner, and side panels, with a stiff bristle brush, and vacuum where necessary.
2. Soiled upholstery, may be cleaned with a good upholstery cleaner suitable for the material. Carefully follow the manufacturer's instructions. Avoid soaking or harsh rubbing.

Leather Upholstery and Seats

For routine maintenance, occasionally wipe leather upholstery with a soft, damp cloth. For deeper cleaning, start with mix of mild detergent and water and, if necessary, work your way up to the products available from Cirrus for more stubborn marks and stains. Do not use soaps as they contain alkali which will alter the leather's pH balance and cause the leather to age prematurely. Cover areas where cleaning solution could cause damage.

• CAUTION •

Solvent cleaners and alcohol should not be used on leather upholstery.

To Clean Leather Upholstery and Seats

1. Clean leather upholstery with a soft bristle brush, and vacuum where necessary.
2. Wipe leather upholstery with a soft, damp cloth.
3. Soiled upholstery, may be cleaned with the approved products available from Cirrus. Avoid soaking or harsh rubbing.

Carpets

To clean carpets, first remove loose dirt with a whiskbroom or vacuum. For soiled spots and stubborn stains use a non-flammable, dry cleaning fluid. Floor carpets may be cleaned like any household carpet.

Recommended Interior Cleaning Products

Cleaning Application	Cleaning Product	Supplier
Interior Windshield and Windows	Plastic and Glass Cleaner	Prist Aerospace
Display Screens	Optimax	PhotoDon
Cabin Interior	Mild Dishwasher Soap (abrasive-free)	Any Source
Leather Upholstery	Leather Care Kit 50689-001	Hemisphere International
	Leather Cleaner 50684-001	Cirrus
	Ink Remover 50685-001	Cirrus
	Leather Conditioner 50686-001	Cirrus
	Spot and Stain Remover 50687-001	Cirrus
Vinyl Panels	Vinyl Finish Cleaner 50688-001	Cirrus
Vinyl and Leather Upholstery	Vinyl & Leather Cleaner	Sprayway, Inc.

Section 9: Log of Supplements

Table of Contents

As Required

FAA Approved POH Supplements must be in the airplane for flight operations when the subject optional equipment is installed or the special operations are to be performed.

This Log of Supplements shows all Cirrus Supplements available for the aircraft at the corresponding date of the revision level shown in the lower left corner. A check mark in the Part Number column indicates that the supplement is applicable to the POH. Any installed supplements not applicable to the POH are provided for reference only.

Section 10: Safety Information

Table of Contents

Introduction.....	3
Taxiing, Steering, and Braking Practices	3
Operating Practices.....	4
Brake Maintenance	4
Cirrus Airframe Parachute System (CAPS).....	5
Deployment Scenarios	5
Mid-Air Collision	6
Structural Failure	6
Loss of Control	6
Landing Required in Terrain not Permitting a Safe Landing.....	6
Pilot Incapacitation	7
General Deployment Information	7
Deployment Speed	7
Deployment Altitude	7
Deployment Attitude	8
Landing Considerations.....	8
Emergency Landing Body Position	8
Door Position	8
Water Landings	9
Post-Impact Fire	9
Ground Gusts	10

Intentionally Left Blank

Introduction

This aircraft is designed to operate safely and efficiently in a flight environment. However, like any other aircraft, pilots must maintain proficiency to achieve maximum safety, utility, and economy. Cirrus strongly recommends that all pilots seek regular recurrent training and that they operate in accordance with the Cirrus Flight Operations Manual and Envelope of Safety.

As the pilot, you must be thoroughly familiar with the contents of this Handbook, the Handbook Supplements, Flight Checklist, and operational guides and data provided by manufacturers of equipment installed in this airplane. You must operate the airplane in accordance with the applicable FAA operating rules and within the limitations specified in Section 2 of this Handbook.

• NOTE •

Refer to [Section 9: Log of Supplements](#) for applicable FAA operating rules.

The Normal Procedures section of this Handbook was designed to provide guidance for day-to-day operation of this airplane. The procedures given are the result of flight testing, FAA certification requirements, and input from pilots with a variety of operational experience. Become fully familiar with the procedures, perform all the required checks, and operate the airplane within the limitations and as outlined in the procedures.

Taxiing, Steering, and Braking Practices

Cirrus aircraft use a castering nose wheel and rely on aerodynamic forces and differential braking for directional control while taxiing. Proper braking practices are therefore critical to avoid potential damage to the brakes.

The most common cause of brake damage and/or failure is the creation of excessive heat through improper braking practices. Pilots unaccustomed to free castering nose wheel steering may be inclined to “ride” the brakes to maintain constant taxi speeds and use the brakes excessively for steering.

• CAUTION •

When brake temperatures are between 270-293 °F (132-145 °C), the Crew Alerting System will display a BRAKE TEMP Caution annunciation. A BRAKE TEMP Warning annunciation occurs when brake temperature exceeds 293 °F (145 °C). If either annunciation occurs, the pilot should stop the aircraft and allow the brakes to cool to avoid damaging the brake system.

Operating Practices

When taxiing, directional control is accomplished with rudder deflection and intermittent braking (toe taps) as necessary. Use only as much power as is necessary to achieve forward movement. Deceleration or taxi speed control using brakes but without a reduction in power will result in increased brake temperature.

On flat, smooth, hard surfaces, do not exceed 1000 RPM maximum continuous engine speed for taxi. Power settings slightly above 1000 RPM are permissible to start motion, for turf, soft surfaces, and on inclines. Use minimum power to maintain constant taxi speed.

“Riding the brakes” while taxiing is similar to driving a car with one foot on the brake and one foot on the gas. This causes a continuous build up of energy that would otherwise be moving the airplane.

Observe the following operating practices:

- Verify that the parking brake is completely disengaged before taxi.
- The rudder is effective for steering on the ground and should be used.
- Use only as much power (throttle) as is necessary to achieve forward movement. Keep in mind, any additional power added with the throttle will be absorbed in the brakes to maintain constant speed.
- Use rudder deflection and the minimum necessary inputs of differential braking to achieve directional control.
- Do not “ride the brakes”. Pilots should consciously remove pressure from the brakes while taxiing. Failure to do so results in excessive heat buildup, premature brake wear, and increased possibility of brake failure or fire.
- Avoid unnecessary high-speed taxiing. High-speed taxiing may result in excessive demands on the brakes, increased brake wear, and the possibility of brake failure or fire.
- Brakes have a large energy absorbing capacity; therefore, cooling time should be considered. Energy absorbed during a few seconds of deceleration can take several minutes to dissipate. Always allow adequate cooling time after brake use.
- Allow a cooling period following a high-energy braking event. High-energy braking can include an aborted takeoff or the equivalent energy required for a Maximum Gross Weight full-stop from 70 knots in less than 1000 feet.

Brake Maintenance

The brake assemblies and linings should be checked at every oil change (50 hours) for general condition, evidence of overheating, and deterioration.

The aircraft should not be operated with overheated, damaged, or leaking brakes. Conditions include, but are not limited to:

- Leaking brake fluid at the caliper. This can be observed by checking for evidence of fluid on the ground or deposited on the underside of the wheel fairing. Wipe the underside of the fairing with a clean, white cloth and inspect for red colored fluid residue.
- Overheated components, indicated by discoloration or warping of the disk rotor. Excessive heat can cause the caliper components to discolor or cause yellowing of the part identification label.

• NOTE •

Refer to [Section 8: Handling and Servicing, "Brake Servicing"](#) for brake system servicing information and brake overheat inspection procedures.

Cirrus Airframe Parachute System (CAPS)

The Cirrus Airframe Parachute System (CAPS) is designed to lower the aircraft and its passengers to the ground in the event of a life-threatening emergency. CAPS deployment will likely result in damage to, or loss of, the airframe, and possible injury to the aircraft occupants. Its use should not be taken lightly. Instead, possible CAPS activation scenarios should be well thought out and mentally practiced by every Cirrus pilot. Pilots who regularly conduct CAPS training and think about using CAPS will often have a higher probability of deploying CAPS when necessary.

The following discussion is meant to guide your thinking about CAPS activation. Cirrus also recommends that pilots discuss CAPS deployment scenarios with instructors as well as fellow pilots through forums such as the Cirrus Owners and Pilots Association. In the event of a spin or loss of aircraft control, immediate CAPS activation is required. (See Section 3) In other situations, CAPS activation is at the informed discretion of the pilot in command. The following discussion is intended to be informative, not directive. It is the responsibility of you, the pilot, to determine when and how the CAPS will be used. It is important to understand, however, that numerous fatalities that have occurred in Cirrus aircraft accidents likely could have been avoided if pilots had made the timely decision to deploy CAPS. It is also important to note that CAPS has been activated by pilots at speeds in excess of 180 knots on multiple occasions with successful outcomes. While the best speed to activate CAPS is below 133 knots indicated airspeed, a timely activation is most important for loss of control situations.

Deployment Scenarios

This section describes possible scenarios in which CAPS activation is appropriate. This list is not intended to be exhaustive, but merely illustrative of the type of circumstances when CAPS deployment could be the most appropriate means of saving the aircraft occupants.

Mid-Air Collision

A mid-air collision likely will render the airplane unflyable by damaging the control system or primary structure. If a mid-air collision occurs, immediately evaluate if the airplane is controllable and structurally capable of continued safe flight and landing. Unless it is apparent that structural and control system damage has not occurred, CAPS activation is recommended. If you are not sure of the condition of the aircraft following a mid-air collision, CAPS activation is recommended.

Structural Failure

Structural failure may result from many situations, such as: encountering severe gusts at speeds above the airplane's structural cruising speed, inadvertent full control movements above the airplane's maneuvering speed, or exceeding the design load factor while maneuvering. If a structural failure occurs, CAPS activation is recommended.

Loss of Control

Loss of control may result from many situations, such as: a control system failure (disconnected or jammed controls); severe wake turbulence, severe turbulence causing upset, severe airframe icing, or pilot disorientation caused by vertigo or panic. If loss of control occurs, the CAPS should be activated immediately.

• WARNING •

In the event of a spin, immediate CAPS activation is mandatory. Under no circumstances should the pilot attempt recovery from a spin other than by CAPS activation.

Landing Required in Terrain not Permitting a Safe Landing

If a forced landing on an unprepared surface is required CAPS activation is recommended unless the pilot in command concludes there is a high likelihood that a safe landing can be accomplished. If a condition requiring a forced landing occurs over rough or mountainous terrain, over water out of gliding distance to land, over widespread ground fog or at night, CAPS activation is strongly recommended. Numerous fatalities that have occurred in Cirrus aircraft accidents likely could have been avoided if pilots had made the timely decision to deploy CAPS.

While attempting to glide to an airfield to perform a power off landing, the pilot must be continuously aware of altitude and ability to successfully perform the landing. Pilot must make the determination by 2000' AGL if the landing is assured or if CAPS will be required.

Pilot Incapacitation

Pilot incapacitation may be the result of anything from a pilot's medical condition to a bird strike that injures the pilot. If incapacitation occurs and the passengers are not trained to land the aircraft, CAPS activation by the passengers is highly recommended. This scenario should be discussed with passengers prior to flight and all appropriate passengers should be briefed on CAPS operation so they could effectively deploy CAPS if required.

General Deployment Information

Deployment Speed

The maximum speed at which deployment has been demonstrated is 133 KIAS. Deployment at higher speeds could subject the parachute and aircraft to excessive loads that could result in structural failure. Once a decision has been made to deploy the CAPS, make all reasonable efforts to slow to the minimum possible airspeed. However, if time and altitude are critical, and/or ground impact is imminent, the CAPS should be activated regardless of airspeed.

Deployment Altitude

No minimum altitude for deployment has been set. This is because the actual altitude loss during a particular deployment depends upon the airplane's airspeed, altitude and attitude at deployment as well as other environmental factors. In all cases, however, the chances of a successful deployment increase with altitude. In the event of a spin, immediate CAPS activation is mandatory regardless of altitude. In other situations, the pilot in command may elect to troubleshoot a mechanical problem or attempt to descend out of icing conditions if altitude and flight conditions permit. As a data point, altitude loss from level flight deployments has been demonstrated at less than 400 feet. Deployment at such a low altitude leaves little or no time for the aircraft to stabilize under the canopy or for the cabin to be secured. A low altitude deployment increases the risk of injury or death and should be avoided. If circumstances permit, it is advisable to activate the CAPS at or above 2,000 feet AGL.

While CAPS activation above 2,000 feet is not necessarily safer than activation at 2,000 feet in terms of the altitude needed to deploy the parachute and slow the descent of the aircraft, there are other risks associated with delaying deployment. Distraction, deterioration in flight conditions, aircraft damage, pilot injury or incapacitation all could take place above 2,000 feet and prevent a timely deployment. At any altitude, once the CAPS is determined to be the only alternative available for saving the aircraft occupants, deploy the system without delay.

Deployment Attitude

The CAPS has been tested in all flap configurations at speeds ranging from V_{SO} to V_A . Most CAPS testing was accomplished from a level attitude. Deployment from a spin was also tested. From these tests it was found that as long as the parachute was introduced to the free air by the rocket, it would successfully recover the aircraft into its level descent attitude under parachute. However, it can be assumed that to minimize the chances of parachute entanglement and reduce aircraft oscillations under the parachute, the CAPS should be activated from a wings-level, upright attitude if at all possible.

Landing Considerations

After a CAPS deployment, the airplane will descend at less than 1700 feet per minute with a lateral speed equal to the velocity of the surface wind. The CAPS landing touchdown is equivalent to ground impact from a height of approximately 10 feet. While the airframe, seats, and landing gear are designed to accommodate the stress, occupants must be prepared for the landing. The overriding consideration in all CAPS deployed landings is to prepare the occupants for the touchdown in order to protect them from injury as much as possible.

Emergency Landing Body Position

The most important consideration for a touchdown with CAPS deployed is to protect the occupants from injury, especially back injury. Contacting the ground with the back offset attempting to open a door or secure items increases the likelihood of back injury. All occupants must be in the emergency landing body position well before touchdown. After touchdown, all occupants should maintain the emergency landing body position until the airplane comes to a complete stop.

The emergency landing body position is assumed with tightened seat belt and shoulder harness by placing both hands beside the legs, and holding the upper torso erect and against the seat backs. The seat cushions contain an aluminum honeycomb core designed to crush under impact to absorb downward loads and help protect the spine from compression injury.

Door Position

For most situations, it is best to leave the doors latched and use the time available to transmit emergency calls, shut down systems, and get into the Emergency Landing Body Position well before impact. The discussion below gives some specific recommendations, however, the pilot's decision will depend upon all factors, including time to impact, altitude, terrain, winds, condition of airplane, etc.

There is the possibility that one or both doors could jam at impact. If this occurs, to exit the airplane, the occupants will have to force open a partially jammed door or break through a door window using the Emergency Exit Hammer located in the lid of the center armrest. This can significantly delay the occupants from exiting the airplane.

If the pilot elects to touchdown with a door opened, there are several additional factors the pilot must consider: loss of door, possibility of head injury, or injury from an object coming through the open door.

- If a door is open prior to touchdown in a CAPS landing, the door will most likely break away from the airplane at impact.
- If the door is open and the airplane contacts the ground in a rolled condition, an occupant could be thrown forward and strike their head on the exposed door pillar. Contacting the ground in a rolled condition could be caused by terrain that is not level, contacting an obstacle such as a tree, or by transient aircraft attitude.
- With a door open, it is possible for an object such as a tree limb or flying debris to come through the opening and strike an occupant.

• **WARNING** •

If it is decided to unlatch a door, unlatch one door only. Opening only one door will provide for emergency egress as well as reduce risks associated with ground contact. Typically, this would be the copilot's door as this allows the other occupants to exit first after the airplane comes to rest.

Water Landings

The ability of the airplane to float after a water landing has not been tested and is unknown. However, since there is the possibility that one or both doors could jam and use of the emergency egress hammer to break out a window could take some time, the pilot may wish to consider unlatching a door prior to assuming the emergency landing body position in order to provide a ready escape path should the airplane begin to sink.

Post-Impact Fire

If there is no fire prior to touchdown and the pilot is able to shut down the engine, fuel, and electrical systems, there is less chance of a post impact fire. If the pilot suspects a fire could result from impact, unlatching a door immediately prior to assuming the emergency landing body position should be considered to assure rapid egress.

Ground Gusts

If it is known or suspected that ground gusts are present in the landing zone, there is a possibility that the parachute could drag the airplane after touchdown, especially if the terrain is flat and without obstacles. In order to ensure that the occupants can escape the airplane in the timeliest manner after the airplane comes to rest, the pilot may elect to unlatch the copilot's door for the CAPS landing. Occupants must be in the Emergency Landing Body Position for touchdown. Occupants must not loosen seat belts until the airplane comes to rest. When the airplane comes to rest, the occupants should exit the airplane and immediately move upwind to prevent a sudden gust from dragging the airplane in their direction.